

SPECIAL 40-CHANNEL CB SECTION

\$1.00 ■ FEB. 1977

Radio-Electronics

THE MAGAZINE FOR NEW IDEAS IN ELECTRONICS

for hi-fi
NEW SPEAKER
matches any amp

40 channel
CB SPECTACULAR
special 16-page bonus

new circuits for
1977 COLOR TV
reception

child
CAR CLOCK
display

ves
RD SYNTHESIZER
child



A
HERNSBACK
PUBLICATION

361256 DLS B0245H97 14 A MAR77
H H BELSCHLAGER 02
BOX 245
BROWNS HILLS NJ 08015

PLUS:

- ★ More On Analog Multimeters
- ★ Jack Darr's Service Clinic
- ★ Komputer Korner ★ Equipment Reports
- ★ Lab Tested Reports On
Soundcraftsman Preamp/Equalizer and Bigston Cassette Deck

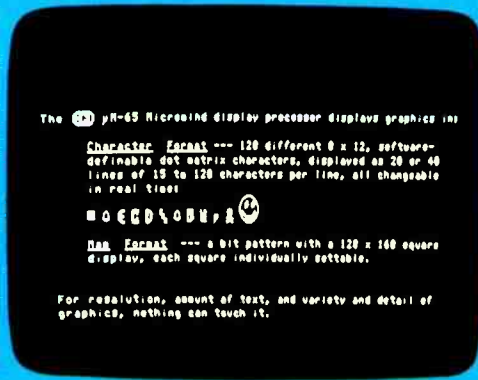

Key Into Maxi-Power @ Micro-Price

Micromind is an incredibly flexible, complete and expandable, hardware/software, general purpose computer system. You won't outgrow it.

Hardware includes an 80 key, software-definable keyboard, I/O interface board, 6500A-series microprocessor (powerful enough for advanced computing), a high-detail graphics and character display processor, power supply, rf modulator, and connections for up to 4 tape recorders plus TV or monitor. An interconnect bus



powerful assembler, a debugger, a file system, graphic routines, and peripheral handlers. We also include dynamic graphic games: Animated Spacewar and Life.

ECD's standard Micromind μ M-65 supplies 8K bytes of memory. Additional

32K byte expansion boards and a mapping option give Micromind expandable access to 64 Megabytes. Utilizing software-controlled I/O channels, Micromind's advanced encoding techniques load data from ordinary tape recorders at 3200 bits per second.

Micromind comes to you ready-to-use, factory assembled and fully tested. Among microcomputers, it has the largest memory capacity and the fastest storage. You're looking at the work of the finest display processor on the market. You won't find a microcomputer with a more powerful CPU.

You won't find a computer with a more flexible keyboard. You won't find anything to touch it at \$987.54.

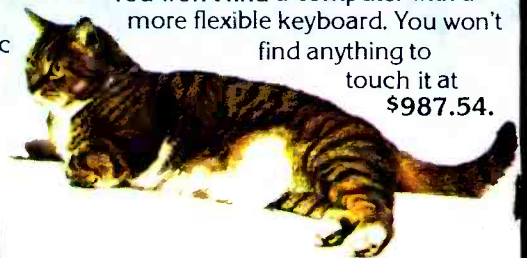

So, quit the kluge scene and key into Micromind. You'll be a main frame performer, with all the comforts of home. We're not fooling... this is the cat's μ !

ECD CORP.
196 Broadway, Cambridge, Mass. 02139
(617) 661-4400



permits 15 additional microprocessors, parallel processing and vastly increased computing power.

System software—including ECD's own notsoBASIC high level language, on advanced error-correcting tape cassettes—provides a word processing editor, a

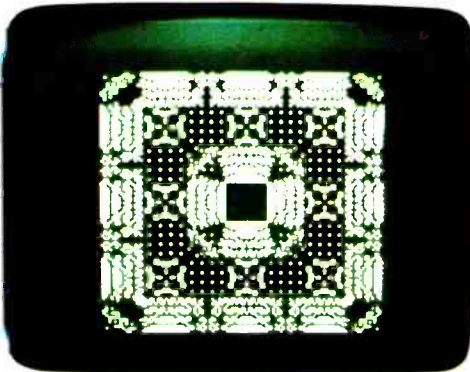

Name _____
Address _____
City/State _____ Zip _____
 Fantastic! Check enclosed: \$987.54. Shipping paid by ECD
 BankAmericard Master Charge Mass. Resident add 5% Sales Tax
_____ Expiration Date _____
Signature _____
 Send me your brochure.

Actual unretouched photographs.

CIRCLE 28 ON FREE INFORMATION CARD



What d'ya mean, you can't fix CBs?

Introducing the Sylvania ECG™ CB10-4 service kit.
26 semiconductors that can turn CB problems into profits.

Until now, the toughest problem in handling CB repair jobs was getting the right replacement part.

Now, we've put the solution to 1,047 of these parts problems in one kit that will fit right on your bench.

The CB10-4 kit has 23 transistors and 3 integrated circuits that are the most frequently needed replacements in transceivers and other CB equipment. And the interchangeability



guide that comes with the kit tells you the right ones to use as replacements. With the CB10-4 most of your parts needs are right at your fingertips. And you can get the others in the same place you bought the kit—at your Sylvania distributor.

We're helping you make it.

GTE SYLVANIA

Shakespeare's White Knight. The best antenna going. And coming.

Shakespeare comes on strong for the new 40 channel era with high performance CB antennas that turn on the power on all 23 or 40 channel CB transceivers.

Shakespeare's new White Knight Antenna combines the rugged, mechanical strength of gleaming white fiberglass with precision engineered electronic components. Components like the high quality loading coil permanently fused in a solid polycarbonate thermoplastic base. Totally impervious to the environment. And pre-tuned to an SWR of 1.9 to 1 or less over the 40 channel band (1.3 to 1 or less at the center). To assure maximum range and peak performance everytime you key the mike. That's what sets the White Knight antenna apart from all the others.

Ride full tilt into the 40 channel era with the new White Knight CB Antenna. And take the Shakespeare performance route home.

The White Knight Antenna, Style 430/available in a variety of pre-assembled mounting styles. Complete with cables and connectors. Under \$25.



Shakespeare

Coming on strong for the Knights of the Road.

Shakespeare Company, Antenna Group, P.O. Box 246, Columbia, S.C. 29202
In Canada: Len Finkler Ltd., Ontario

Radio-Electronics®

THE MAGAZINE FOR NEW IDEAS IN ELECTRONICS

Electronics publishers since 1908

FEBRUARY 1977 Vol. 48 No. 2

CB RADIO

- 32 **Equipment Report**
B&K CB tester
- 39 **40-Channel CB Spectacular**
Special 16-page report on new developments in 40-Channel CB starts here.
- 40 **40-Channel Equipment Roundup**
A manufacturer by manufacturer look at what will be available in 40-channel CB gear. **by Fred Petras**
- 45 **Antennas For 40-Channels**
Are they special? Can you use your old 23-channel antenna? Do you need a new one? **by Richard Bitner**
- 47 **Phase Lock Loop**
How it works for 40-Channel gear. **by Robert F. Scott**
- 50 **New FCC Rules**
Changes that affect 40-channel operation that you must know about.
- 51 **Manufacturers of 40-Channel CB Transceivers**
Who's making what. Final report at press time of the 150 FCC-approved 40-channel gear.
- 54 **Coax Connector A Cinch**
New coax connector is a cinch to install. No soldering is needed. **by Fred Shunaman**

BUILD ONE OF THESE

- 58 **Keyboard Synthesizer**
Part II: Final construction details. **by John Simonton**
- 61 **Digital Car Clock**
It's easy to build and puts digital time in your car. **by Robert Arp**

TELEVISION

- 55 **Color TV '77**
A look at the newest circuits in this year's solid state Color sets. **by Karl Savon**
- 78 **Service Clinic**
Screen controls **by Jack Darr**
- 79 **Reader Questions**
R-E's Service Editor solves reader problems

HI-FI STEREO

- 64 **Amplifier/Speaker Interfaces**
New BIC speaker system. **by Len Feldman**
- 67 **R-E Lab Test Report**
Soundcraftsman PE 2217 preamp equalizer.
- 69 **R-E Lab Test Report**
Bigston BSD-300 cassette deck.

TEST EQUIPMENT

- 34 **Equipment Report**
Jerrold Texscan VSM-5 Spectrum Analyzer.
- 75 **Analog Multimeters**
Part II: Specification, features and applications. **by Charles Gilmore**

GENERAL ELECTRONICS

- 4 **Looking Ahead**
Tomorrow's news today. **by David Lachenbruch**
- 22 **Komputer Korner**
How microcomputers make a decision. **by John Titus, David Larsen and Peter Rony**
- 100 **State of Solid State**
What's happening in IC & Transistor development now. **by Karl Savon**

DEPARTMENTS

- | | |
|-------------------------------------|----------------------------------|
| 106 Advertising Index | 98 New Literature |
| 12 Advertising Sales Offices | 92 New Products |
| 14 Letters | 99 Next Month |
| 105 Market Center | 107 Free Information Card |
| 6 New & Timely | |

ON THE COVER

40-channel CB went into effect January 1, 1977. Right now, all kinds of 40-channel gear is on sale. The 40-channel dial on our cover symbolizes this development. To bring you all the latest information we have produced the special 16-page section starting on page 39 of this issue.

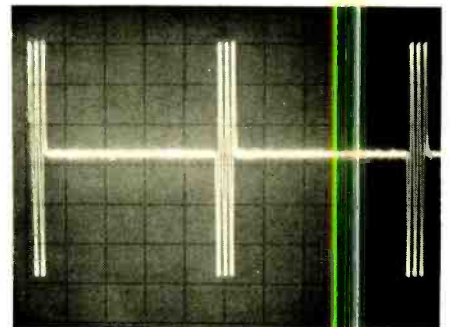

THIS TEST SIGNAL was used to test a new concept in speaker design. Get the whole story. See story starting on page 64.

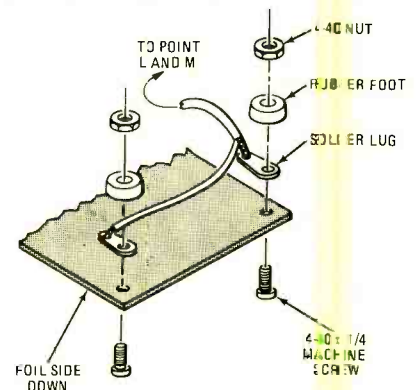

PITCH BENDER BOARD is important part of keyboard synthesizer. See page 58.

Radio-Electronics, Published monthly by Gernsback Publications, Inc., 200 Park Avenue South, New York, NY 10003. Phone: 212-777-6400. Second-class postage paid at New York, NY and additional mailing offices. One-year subscription rate: U.S.A., U.S. possessions and Canada, \$8.75. Pan-American countries, \$10.25. Other countries, \$10.75. Single copies \$1.00. © 1977 by Gernsback Publications, Inc. All rights reserved. Printed in U.S.A.

Subscription Service: Mail all subscription orders, changes, correspondence and Postmaster: notices of undelivered copies (Form 3579) to Radio-Electronics Subscription Service, Box 2520, Boulder, CO 80302.

A stamped self-addressed envelope must accompany all submitted manuscripts and/or artwork or photographs if their return is desired should they be rejected. We disclaim any responsibility for the loss or damage of manuscripts and/or artwork or photographs while in our possession or otherwise.

As a service to readers, Radio-Electronics publishes available plans or information relating to newsworthy products, techniques and scientific and technological developments. Because of possible variances in the quality and condition of materials and workmanship used by readers, Radio-Electronics disclaims any responsibility for the safe and proper functioning of reader-built projects based upon or from plans or information published in this magazine.

looking ahead

TED visits United States: The only videodisc system currently on the market anywhere—the TED system, developed by Telefunken of Germany and Decca of Great Britain—was shown recently for the first time in the United States in NTSC color format. The player and a small selection of discs have been on the market in Germany since March 1975 with less than spectacular public acceptance. TED discs measure $8\frac{3}{4}$ inches (21 cm) in diameter, and each thin flexible disc has a playing time of 10 minutes. Recording is done on the hill-and-dale principle and a diamond-tipped "pressure stylus" reads the "bumps" as the disc revolves at 1800 RPM on a cushion of air.

In Germany, the player sells for \$500-\$600, with discs at \$4-\$10 each, but Telefunken officials maintain that in large-scale production players could retail as low as \$200-\$300. A prototype automatic changer that can accommodate up to 12 discs, with a four-second changing time, was also demonstrated. Picture quality and color produced by the player and changer were extremely good during the demonstration.

Despite the slow consumer acceptance in Germany—which Telefunken attributes to low program quality and quantity—the TED player will be manufactured for the NTSC color market by two Japanese firms, Sanyo and General. Two other Japanese companies will manufacture discs, with marketing scheduled to start in Japan in April, well ahead of the estimated December 1977 "test-marketing" date for the Philips-MCA-Magnavox and RCA LP videodisc systems in the U. S. The TED system could show up in this country before the year is over. Sanyo markets television sets here under its own brandname and is also a principal supplier to Sears, Roebuck and Co. General's sets are handled on a private-label basis, and under the Teknika brandname, principally by department stores.

Home VTR suit: A legal challenge to the very concept of home videocassette recording has been filed against Sony by two movie companies. Universal Pictures and Walt Disney Studios jointly sued Sony, its advertising agency, a group of Southern California Sony dealers and one owner of a Betamax home videocassette recorder, charging that Sony is encouraging copyright violations by making VTR's available to consumers to tape copyrighted movies shown over TV. The suit asks injunctions against manufacture, sale and use of the machines for this purpose and seeks to have the court order all tapes of the studios' copyrighted shows destroyed.

Sony promptly denied that Betamax violates copyrights, calling it a "time-shift machine" that makes it possible for viewers to watch programs at more convenient times. Sony indicated it felt the movie companies were trying to invade consumers' homes and tell them how and when they could see programs broadcast on the publicly owned airwaves. The entire future of home videotape recording of broadcast programs could rest on the outcome of the case.

It's generally agreed that taping a copyrighted show

from television and then exhibiting the tape for an admission charge, or selling the tape, would be illegal. But the concept of making tapes from the air for personal use has rarely been challenged in the past. In fact, a 1972 phonograph record anti-piracy law expressly exempts audio recordists who make tapes off the air for their own use from being penalized by law. Whether that precedent extends to video presumably will be decided by the courts.

TV makers' blues: Is the American television manufacturing industry destined to go the way of the domestic radio industry—in other words, out of existence? The substantial increase in total U.S. TV sales in 1976 over 1975 appears almost totally to reflect a substantial increase in imports. In the first nine months of 1976, imports represented 32.8% of the color TV supply, up from 17.1% in the same months of 1975, and 70.5% of black-and-white, as compared with 67.4% a year earlier. Imports' share of the color market in the third quarter rose to a record 43.9%.

One of the casualties of low sales of domestically produced TV sets was Westinghouse's color tube business. The company stopped production last December, leaving only four firms manufacturing color tubes for U. S. set manufacturers—G-E, GTE Sylvania, RCA and Zenith. Meanwhile, some U. S. TV set and component manufacturers, along with labor unions, are seeking government action to trim imports of Japanese color sets on the grounds of "unfair competition" and damage to the domestic industry.

The Elcaset arrives: Cassette convenience with open-reel sound comes at a relatively high price in the new Elcaset decks now being introduced. The Elcaset is about $2\frac{1}{2}$ times as large as a conventional compact cassette and contains $\frac{1}{4}$ -inch tape that moves at a speed of $3\frac{3}{4}$ IPS. The system is designed for audio automation—special cut-out holes in the case are used to automatically set bias and equalization circuits for any of three different types of tape (low-noise, chrome and Ferrichrome) and switch Dolby circuits in or out. Provision is also made for the use of a special control head in professional models for automatic cueing and program control. Frequency response is claimed to be equal to open-reel tapes.

Elcaset's operation differs from that of a conventional cassette in that the tape is pulled out of its case when inserted in the deck, and three heads can be used (record, playback and erase)—four, with the addition of the control head. The system was developed in Japan by Sony and Teac. Technics by Panasonic will introduce a single-motor Elcaset deck next June at \$750, and a four-motor professional model at about \$2,000. Superscope and Teac also have scheduled sale of Elcaset decks in the U. S. Sony, Toshiba, Aiwa and JVC have also shown models in Japan.

DAVID LACHENBRUCH
CONTRIBUTING EDITOR

Introductory offer to new members of the ELECTRONICS AND CONTROL ENGINEERS' BOOK CLUB

any one
of these great
professional books
for only **\$1.00**
values up
to \$42.50

Special \$1.00 bonus book comes to you
with your first club selection

353/387
**MINICOMPUTERS
FOR ENGINEERS AND
SCIENTISTS**
by G. A. Korn
Pub. price, \$23.45
Club price, \$15.50

287/341
**STANDARD
HANDBOOK OF
ENGINEERING
CALCULATIONS**
by T. G. Hicks
Pub. price, \$19.50
Club price, \$15.25

617/97X
**HANDBOOK OF
OPERATIONAL
AMPLIFIER
CIRCUIT DESIGN**
by D. E. Stout
& M. Kaufman
Pub. price, \$24.50
Club price, \$17.50

771/189
**ELECTRONIC
TROUBLE-
SHOOTING**
by C. N. Herrick
Pub. price, \$13.95
Club price, \$10.95

124/485
**ELECTRICAL
ENGINEERING
FOR
PROFESSIONAL
ENGINEERS
EXAMINATIONS,
3/e**
by J. D. Constance
Pub. price, \$17.00
Club price, \$12.50

404/453
**GUIDEBOOK OF
ELECTRONIC
CIRCUITS**
by J. Markus
Pub. price, \$26.95
Club price, \$21.50

767/556
**RAPID
PRACTICAL
DESIGNS OF
ACTIVE FILTERS**
by D. E. Johnson
& J. L. Hilburn
Pub. price, \$15.00
Club price, \$11.50

771/480
**MANUAL FOR
MOS USERS**
by J. D. Lenk
Pub. price, \$16.95
Club price, \$12.95

637/458
**DESIGNING
WITH TTL
INTEGRATED
CIRCUITS**
by Texas
Instruments,
Inc.
Pub. price, \$26.00
Club price, \$17.50

771/456
**DIGITAL
ENGINEERING,
2/e**
by G. K.
Kostopoulos
Pub. price, \$24.95
Club price, \$18.95

238/901
**APPLICATIONS
OF OPERATIONAL
AMPLIFIERS:
Third-Generation
Techniques**
by J. G. Graeme
Pub. price, \$18.65
Club price, \$11.95

209/804
**ELECTRONICS
ENGINEERS'
HANDBOOK**
by D. G. Fink
Pub. price, \$42.50
Club price, \$32.50

423/156
**INTEGRATED
ELECTRONICS:
Analog Digital
Circuits &
Systems**
by J. Millman
& C. Halkias
Pub. price, \$21.00
Club price, \$15.95

209/731
**STANDARD
HANDBOOK FOR
ELECTRICAL
ENGINEERS,
10/e**
by D. J. Fink &
J. M. Carroll
Pub. price, \$41.50
Club price, \$28.50



save time and money by joining the ELECTRONICS AND CONTROL ENGINEERS' BOOK CLUB



Here is a professional book club designed to meet your on-the-job engineering needs by providing practical books in your field on a regular basis at below publisher prices. If you're missing out on important technical literature—if today's high cost of reading curbs the growth of your library—here's the solution to your problem.

The *Electronics and Control Engineers' Book Club* was organized for you, to provide an economical reading program that cannot fail to be of value. Administered by the McGraw-Hill Book Company, all books are chosen by qualified editors and consultants. Their understanding of the standards and values of the literature in your field guarantees the appropriateness of the selections.

How the club operates: Every month you receive free of charge *The Electronics and Control Engineers' Book Club Bulletin*. This announces and describes the Club's featured book of the month as well as alternate selections available at special members' prices. If you want to examine the Club's feature of the month, you do nothing. If you prefer one of the alternate selections—or if you want no book at all—you notify the Club by returning the card enclosed with each Bulletin.

As a Club member, you agree only to the purchase of four books (including your first selection) over a two-year period. Considering the many books published annually, there will surely be at least four you would want to own anyway. By joining the Club, you save both money and the trouble of searching for the best books.

MAIL THIS COUPON TODAY

ELECTRONICS AND CONTROL ENGINEERS' BOOK CLUB
P.O. Box 582, Princeton Road, Hightstown, New Jersey 08520

Please enroll me as a member and send me the two books indicated. I am to receive the bonus book at the introductory price of \$1.00 plus my first selection, plus tax, postage and handling. If not completely satisfied, I may return the books within 10 days and request that my membership be cancelled. If I keep the books, I agree to take a minimum of three additional books during the next two years at special Club prices (guaranteed 15% discount, often more). I will receive the Club Bulletin 12 times a year. If I want to examine the featured selection, I need take no action. It will be shipped automatically. If, however, I want an alternate selection—or no book at all—I simply notify the Club by returning the convenient card always enclosed. I will always have a minimum of ten days in which to return the card and you will credit my account fully, including postage, if this is not the case. Membership in the Club is continuous but cancellable by me at any time after the four-book purchase requirement has been filled. This order subject to acceptance by McGraw-Hill. Orders from outside the continental U.S. must be prepaid. All prices subject to change without notice. Offer good for new members only.

Write Code # of \$1.00 bonus
book selection here

Write Code # of
first selection here

NAME _____

ADDRESS _____

CITY _____

STATE _____ ZIP _____

EXTRA SAVINGS: Remit in full with your order, plus any local and state tax, and McGraw-Hill will pay all postage and handling charges. **E 33310**

CIRCLE 37 ON FREE INFORMATION CARD

www.americanradiohistory.com

Worldwide TV by phone possible with new slow-scan system

It is now possible for televised pictures to be transmitted from one or more CCTV cameras to anywhere in the world by telephone.

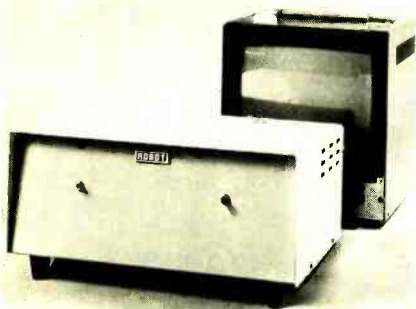

THE ROBOT 500 SCAN CONVERTER

The Phoneline Television System uses a scan converter that converts the broadband 525-line image to a 128-line by 128-element image. The camera "frame-grabs" a complete image every eight seconds and transmits it to the monitor during the period between then and picking up the next image. At the monitor, the picture is displayed eight seconds, then replaced by the next one with a wiping effect. The new image begins at the top of the screen and goes to the bottom.

The manufacturer, Robot Research, San Diego, CA, reports that the system is based on their Robot Series 500 scan converter, which does the frame-grabbing and converting to a signal that can be transmitted at audio frequencies.

"You must raise your prices" RCA official tells technicians

"You should raise your prices," RCA vice president Arnold Valencia told the National Electronics Service Dealers Association at their 1976 convention in San Antonio, TX. "It is important," he said, "that you try to cut your costs by raising efficiency. But I realize that there is a limit to how much you can increase that efficiency. When you reach bottom costs, you have no choice. You have to raise your prices."

He continued: "But I warn you, RCA will challenge you if you raise your charges for doing warranty work on our products. You'll have to justify any request for a price increase by substantiating your costs. Therefore, you'd better understand those costs."

Unfortunately, not all manufacturers were in agreement as to the need for receiving at least cost for doing warranty work. Ray Yeranko, national service manager of Magnavox, said his firm was "a

friend of the independent service industry." Yet just the day before, the convention had heard the text of a 7-page telegram that Yeranko had used to defeat a California Senate bill prohibiting below-cost warranty work. Magnavox's reasoning, as expressed in the telegram, was that "Service agencies adopt warranty business 'below-cost' only because they can obtain out-of-warranty business as a result of prior contracts. Apparently the out-of-warranty customers are to be expected to pay part of the manufacturer's cost for in-warranty servicing.) The telegram went on to state that higher prices "could result in a manufacturer's decision to discontinue the use of independent agencies, and to perform the service himself."

The convention was also informed that a General Electric lobbyist, Robert Jordan, had appeared personally before the Finance, Insurance and Commerce committee of California's lower legislative house to defeat the measure.

FCC seizes record quantity of illegal CB radio equipment

More than \$65,000 worth of illegally used radio equipment was confiscated late last October in a crackdown on illegal radio transmission in Baltimore and the surrounding five counties, according to Jervis S. Finney, US Attorney for Maryland. This was the largest simultaneous execution of search and seizure warrants against illegal radio operators in this country, he said.

The illegal radio stations were reported to have been transmitting on unauthorized frequencies, operating overpowered equipment, invading and overpowering CB channels, and disrupting the communications of legitimate CB users.

No less than 19 search warrants were executed simultaneously by United States Marshals from Baltimore and Washington, accompanied by FCC agents from the Baltimore, Washington, Philadelphia and Norfolk field offices. Operators of the stations, if convicted, face possible fines of up to \$500 per day of illegal operation, and a maximum of one year of imprisonment and a \$10,000 fine for unlicensed use of CB or amateur equipment.

British cable TV programs transmitted over optical line

Cable TV subscribers in the Hastings area of England are now watching TV programs that have made part of their journey to the viewer through a glass cable instead of a metal conductor. Rediffusion Ltd. of London reports that some 34,000 subscribers are now receiving their programs over a line that consists in part of a 1.4-kilometer (about 0.9-mile)

length of optical cable.

Electrical signals are converted into light by a Plessey gallium-arsenide light-emitting diode, and back to electrical signals at the other end of the optical line with a photodiode. The cable consists of two strands of extremely pure optical glass, made by Corning in the United States. They are encased in a 7 x 4-millimeter polyethylene sheath with two 1-mm steel wires for mechanical strength. The optical fibers are carried loosely in a rectangular cavity.

Rediffusion reports that information-carrying capacity, compactness and lightness, and eventually lower cost are the three factors leading the company to experiment with optical cable, which can carry 10,000 times as much information per cable as coax.

Greager, Holman and Wiles win Gernsback Awards

This month's winner of the Hugo Gernsback Memorial Scholarship Award, a check for \$150 presented annually to an outstanding student in each of eight leading electronics home-study schools, is Alan B. Greager of Nucla, CO.



ALAN B. GREAGER

Mr. Greager completed studies in a technical trades institute, then enrolled with the International Correspondence Schools in their FCC Radiotelephone License program. He states that one of his reasons for taking the course was that he needed additional knowledge about circuits on which he was working.

"From the first lesson," he says, "I have been able to incorporate the knowledge presented by ICS with my job skills. I found that ICS would give me credit for my previous schooling, and offered a toll-free number on which any student can have a direct conversation with instructors. I was also allowed to add to my course lessons that were not required but which I desired.

continued on page 12

now 3-strong

Xcelite® family of attaché tool cases



TC-150/ST

And here's the newest addition... Model TC-150/ST... containing an intermediate assortment of tools for the technician, serviceman, or field engineer. It contains 52 items in all, including 24 famous Xcelite "Series 99" interchangeable-blade tools, a broad variety of other Xcelite Professional screwdrivers, nutdrivers, pliers, cutters, strippers, measuring tapes, and specialized electronic tools, plus the Weller® Cordless Soldering Iron and recharger, an added convenience where outlets aren't accessible. Tools are mounted in see-thru pockets on removable pallets in a durable, attractive case with Whiskey-tan Marvelon exterior and sun-tan vinyl lining. Plenty of extra space for additional tools, prints and manuals! Solid brass hardware and padded handle are additional quality touches.

It joins the other members of the family... Model TC-100/ST, the "big daddy" of Xcelite's cased tool sets, with the greatest variety—a total of 86 types and sizes of drivers, wrenches, pliers, cutters, strippers...and Model TC-200/ST, the 37-piece set that's unequalled in economy and value. See the new TC-150/ST at your distributor now. And ask for Xcelite literature, which will give you a detailed listing of the contents of all three Xcelite Attaché Tool Cases.



TC-100/ST



TC-200/ST



Weller-Xcelite Electronics Division
The Cooper Group

Apex, N. C. 27502

CIRCLE 27 ON FREE INFORMATION CARD

Only NRI

25" designed-

DIAGONAL

Color TV



Quadraphonic



Two home training schools give you a hobby-kit Color TV to assemble. Two others give you a commercial set right off the shelf. Neither was designed to teach you how to repair Color TV's. Only NRI invested the time and money to design equipment with learning in mind!

No other home training school gives you both a solid state Color TV and SQ™ Quadraphonic Receiver complete with four speakers . . . all in one course. In fact, to even match this kind of thorough training at another school, you'd have to take an extra

course costing hundreds of dollars more. And only NRI courses in Color TV/Audio servicing let you learn on equipment designed specifically for training.

It's the only way you can (1) get the feel of typical commercial circuitry, (2) learn bench techniques while building complete units from the "ground" up, (3) perform over 35 "in-set" experiments during construction, and (4) end up with a 25" diagonal solid state Color TV with cabinet and a 4-channel Audio Center.

NRI passes the savings on to you

NRI engineering eliminates the cost of buying from an outside source. We pay no salesman's commission. Students are enrolled by mail only. The savings are passed on to you in the form of low tuition fees, extras like the TV's console cabinet and the Quadraphonic System; professional test instruments like a 5" triggered sweep oscilloscope, CMOS digital frequency counter, and integrated circuit Color TV pattern generator. You can pay hundreds of dollars more for similar courses and not

™ Trademark of CBS, Inc.

gives you this for-learning ..plus complete Audio Center.

get a nickel's worth more in training and equipment.

More know-how per dollar

It all boils down to the quality of training you get for your money. In our 62-year history, more than a million students have come to NRI and we're fully approved for career training under the G.I. Bill. We know the right way to make home training pay dividends for you.

Some of those "right" things are bite-size lessons to ease understanding and speed learning . . . personal consultation, and prompt grading of all tests . . . a full-time staff of engineer/instructors to help if you need it . . . the right kind of kits and experiments to give you hands-on training . . . and fully professional programs oriented to full or part-time career needs.

Also CB, Computer, & Other Courses

NRI offers not one, but five TV/Audio servicing courses so you can tailor your training to your budget. Or you can study other opportunity fields like Digital Computer Electronics, Citizens Band Radio, Communications, Aircraft or



Marine Electronics,
Mobile Radio and more.
Send for your free catalog and
see for yourself that no one gives you
more training and equipment for your
dollar. There's no obligation and no
salesman will call.

If card is missing, write to:



NRI SCHOOLS
McGraw-Hill Continuing
Education Center
3939 Wisconsin Avenue,
Washington, D.C. 20016

Second most outstanding student in the ICS screening is David Holman of Dickson, TN. He writes in part:

"When I started my course in Electronics I was doing manual work in a small repair shop. As I progressed in my studies the job got better and better, and in a few months I was running all the service calls. The shop was then moved to a new location, with me running it. Since then I have left that job and started 'Holman's TV Repair.' In seven months it has grown from a small repair shop to a very nice sales and service center. Without the superior education in electronics I gained



DAVID HOLMAN

from ICS, I would probably still be helping to set TV's up on the bench for someone else."

Mr. Holman receives a model 280 digital multimeter donated for the purpose by B & K.

In third place this month is Terry W. Wiles of Plattsmouth, NE, a graduate of the ICS TV Service Technician program,

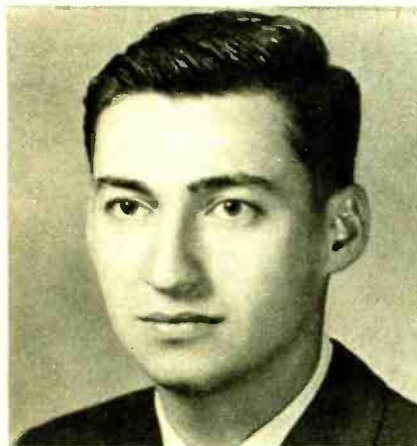

TERRY W. WILES

who receives a WV-529A special service VOM through the generosity of VIZ Manufacturing Co. He writes:

"I started my ICS TV course in late 1973 and completed it in March, 1975. Since then, I have opened a TV-radio service shop and am doing service work in eastern Nebraska and southwestern Iowa. I'm also working with a store in Melvern, IA. I don't believe things would have gone so smoothly if it had not been for the fine training and knowledge I gained through my ICS course. . . ."

OOOOOOPS!

We blew it! It seems we made an error in reporting the Hugo Gernsback Memorial Scholarship Award winners in the December, 1976, issue. The photographs for the second place winner, Mr. Joseph E. Homy, and the third place winner, Mr. Robert Graham, were inadvertently mixed up so that the names appeared under the wrong photographs. To set things straight, we would like to apologize to Mr. Homy and Mr. Graham for the mix up. The photographs, with the correct names, are shown below.



JOSEPH E. HOMOY



ROBERT GRAHAM

The first place winner Mr. A. H. Christ, was correct as it appeared.

Hugo Gernsback (1884-1967) founder
M. Harvey Gernsback, KOD-6694
 editor-in-chief and publisher
Larry Steckler, KTX-3644, CET, editor
Robert F. Scott, CET, W2PWG,
 KXK-8533, technical editor
Arthur Kleiman, KTZ-3288, associate
 editor
Jack Darr, CET service editor
Leonard Feldman
 contributing high-fidelity editor
Karl Savon, semiconductor editor
David Lachenbruch, contributing editor
Rudolph F. Graf, contributing editor
George Whalen, contributing editor
Vincent P. Cicenia, production manager
Dale Allinson, production assistant
Harriet I. Matysko, circulation director
Sheila Wertling, circulation assistant
Arline R. Bailey, advertising coordinator

Cover design by Louis G. Rubsamen

Cover photo by Walter Herstatt

Radio Electronics is a member of the Institute of High Fidelity and is indexed in Applied Science & Technology Index and Readers Guide to Periodical Literature.



Radio-Electronics magazine is published by Gernsback Publications, Inc. 200 Park Ave. S., New York, NY 10003 (212) 777-6400

President: M. Harvey Gernsback

Vice President: Larry Steckler

Treasurer: Carol A. Gernsback

Secretary: Bertina Baer

ADVERTISING SALES

EAST

Stanley Levitan, KZA-5580, Sales Manager
 Radio-Electronics
 200 Park Ave. South
 New York, NY 10003
 (212) 777-6400

MIDWEST/Texas/Arkansas/Okla.

Ralph Bergen, KXD-8396
 Jim Reilly
 The Ralph Bergen Co.
 6319 N. Central Ave.
 Chicago, IL 60646
 (312) 792-3646

PACIFIC COAST Mountain States

Jay Eisenberg, KYF-3277
 J.E. Publishers Representative Co.,
 8732 Sunset Blvd.,
 4th Floor,
 Los Angeles, CA 90069
 (213) 659-3810
 Sales Mart Building
 1485 Bayshore Blvd., Box 140
 San Francisco, CA 94124
 (415) 467-0125

SOUTHEAST

J.E. Publishers Representative Co.,
 214-387-2424

ANNOUNCING THREE NEW BREAKTHROUGHS IN SOLDERLESS BREADBOARDING.

Whether you design or build circuits for fun or for profit, you owe it to yourself to discover how fast and easy CSC solderless breadboarding can be. Now, more than ever. Because of three new breakthroughs in breadboard design. And our new EXPERIMENTOR™ sockets** that make the most of them.

1. Price Who says a quality breadboard has to be expensive? For as little as \$9.95, CSC's EXPERIMENTOR sockets let you design, assemble and modify circuits as fast as you can push in—or pull out—component leads. On a rugged one-piece socket with 550 solderless tie-points (94 five-point terminals and two 40-point bus strips).

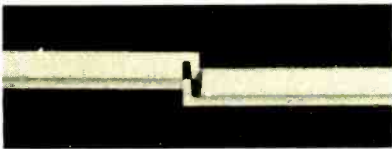

Sockets lock together, snap apart to handle any size circuit with ease.

But don't let the low price fool you: EXPERIMENTOR sockets are precision-molded of durable, abrasion-resistant material, and feature CSC's non-corrosive, prestressed nickel-silver contacts for positive connections and longer life. All contacts are identified, too... with molded-in designations for easier circuit assembly and diagramming.

2. Compatibility CSC EXPERIMENTOR sockets end the "big-chip blues." They're the only ones with full fan-out capabilities for microprocessors and other larger DIP's, as well as 4-16-pin units. EX-

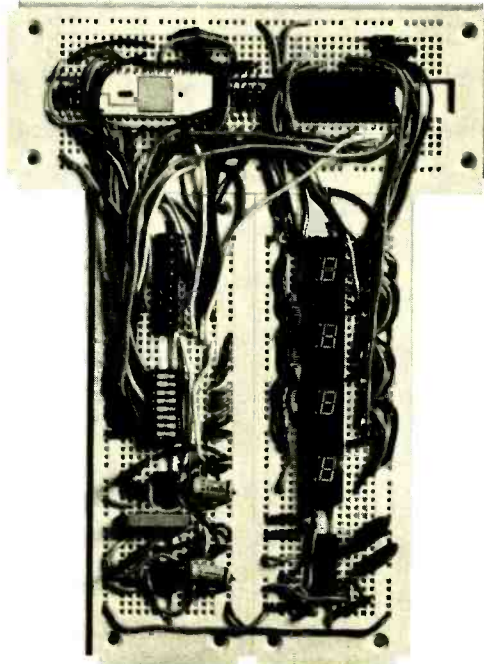

PERIMENTOR 600's 6/10" center is ideal for microprocessors, clock chips, RAM's, ROM's, PROM's, etc. While EXPERIMENTOR 300's smaller 3/10" center is perfect for smaller DIP's. Both units, of course, accept transistors, LED's, resistors, capacitors, pot's—virtually all types of components with plug-in ease. As well as #22-30 solid hook-up wire for interconnections. Eliminating heat and lead damage to expensive components. And saving you more money, on parts.



Mix or match both models; arrange them vertically or horizontally.

3. Flexibility With CSC EXPERIMENTOR sockets, you can arrange your breadboard to suit your circuit... instead of vice versa. An exclusive snap-together inter-

locking system lets you instantly connect them. Vertically or horizontally. So you can mix or match 3/10 and 6/10" centers... expanding or contracting to meet your requirements.

CSC EXPERIMENTOR sockets can be used alone, or mounted on any convenient flat surface, thanks to molded-in mounting holes and vinyl insulation backing that prevents shorts. You can mount them with 4-40 flat-head screws from the front, or 6-32 self-tapping screws, from the rear. But however you use them, EXPERIMENTOR sockets are an unbeatable way to build and test twice the projects in half the time.



Both models feature 94 five-point terminals (vertical lines) and two 48-point bus strips (one strip shown).

WHY WAIT? CSC EXPERIMENTOR sockets are available now from your CSC dealer, or by phone from CSC, at \$9.95* for the 300 and \$10.95* for the 600. Call 203-624-3103 (East Coast) or 415-421-8872 (West Coast)—major credit cards are accepted.

*Manufacturer's suggested list price
Prices subject to change without notice
U.S. Pat. No. D235,554

CONTINENTAL SPECIALTIES CORPORATION



44 Kendall Street, Box 1942, New Haven, Ct 06509
203-624-3103/TWX: 710-435-1227
West Coast office: Box 7809, San Francisco, CA 94119
415-421-8872/TWX: 910-372-7992

CIRCLE 67 ON FREE INFORMATION CARD

www.americanradiohistory.com

THE INSTANT DIGITAL CB TESTER



Now one unit does it all.

The Hickok Model 388 CB in-line Tester hooks up to any CB transmitter and tells you everything you need to know, instantly, digitally.

Push a button to switch from in-line to front panel input and it becomes a high sensitivity 7 digit frequency counter for measuring any frequency from 10Hz to 55MHz.

Add a pair of wires, and you can power it from any 12V source for in-the-car or other remote operations.

MODEL 388 \$349
MODEL 388X \$475

Model 388 has a 10ppm (.001%) time base accuracy.

Model 388X contains a precision TCXO with 1ppm accuracy.

Part of the

HICKOK
Comm Line

the full line of professional CB service instruments.

HICKOK
the value innovator

INSTRUMENTATION & CONTROLS DIVISION
THE HICKOK ELECTRICAL INSTRUMENT CO.
10514 Dupont Avenue • Cleveland, Ohio 44108
(216) 541-8060 • TWX: 810-421-8286

letters

DIGITAL SINEWAVES

Don Lancaster's article entitled "Create Sinewaves Using Digital IC's" that appeared in the November, 1976, issue was both interesting and useful. Using a 4018 IC, we built the five-stage synthesizer shown in Fig. 6 of the article. With 1% summing resistors, the output waveform shown in Fig. 1 was obtained. The scope was set to 1 ms-per-division and 0.5 volts-per-division. The harmonic content of the output signal was analyzed and is listed in Table 1.

TABLE 1—HARMONIC CONTENT of five-stage synthesizer.

Harmonic	Frequency (Hz)	Amplitude (dB)
1	200	0
3	600	-17
5	1000	<-60
7	1400	-14
9	1800	-20
11	2200	-21
13	2600	-27
15	3000	<-60
17	3400	-21
19	3800	-16
21	4200	-17
23	4600	-33
25	5000	<-60

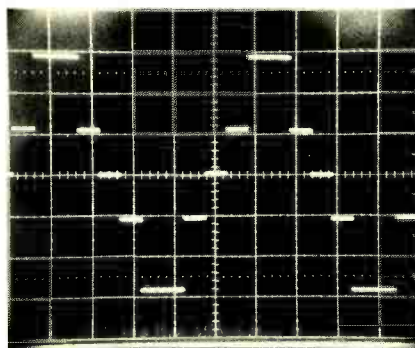

FIG. 1

TABLE 2—HARMONIC CONTENT of modified synthesizer.

Harmonic	Frequency (Hz)	Amplitude (dB)
1	200	0
3	600	-57
5	1000	<-60
7	1400	-54
9	1800	-19
11	2200	-20
13	2600	-60
15	3000	<-60
17	3400	-60
19	3800	-25
21	4200	-26
23	4600	<-60
25	5000	<-60

In the waveform of Fig. 1, the distance between the bottom level and the first step is larger than the distance between the first step and the second step. A better sinewave approximation would have a larger distance between the 1st and 2nd steps, than between the bottom level and the first step. If the 22.1K and 35.7K resistors are switched, the output waveform shown in Fig. 2 is obtained. The scope settings are the same as before. The harmonic content of this output signal was analyzed and is listed in Table 2.

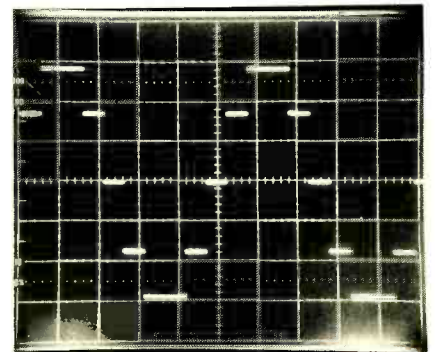

FIG. 2

The modification produces a better approximation that follows the harmonic content specified in the article.

The resistor values obtained in Table 1 of the article are also incorrect. The proper values can be determined from the reciprocal of the numbers shown in the parenthesis in Table 1 of the article. For a six stage counter, the resistors should be: 44.2K (1,000), 25.5K (.577), 22.1K (.500), 25.5K (5.77), and 44.2K (1,000).

Thanks again for a useful and interesting article, keep up the good work.

JOHN PEASE and
GIL JOHNSON
Marquette Electronics
Milwaukee, WI

OPEN LETTER—AM STEREO

Secretary
Federal Communications Commission
Washington, DC

Dear Sir:

The Federal Communications Commission has announced tender of a petition for rule-making (RM-2717) submitted by Kahn Communications, Inc., of Freeport, New York, I, as an individual, a taxpayer and broadcaster, wish to endorse issuance of a notice of proposed rule-making in this matter.

There are several reasons for this endorsement of the Kahn System:

1) Since I am Program Director at WFBR, I have worked with the Kahn Stereo equipment and I know it works.

continued on page 16

TUNER SERVICE CORPORATION

SUBSTITUNER



\$4995
U.S.A. ONLY

WITH CABLES

ONE YEAR
GUARANTEE



\$1095
U.S.A. ONLY

FEATURES

- A UHF Tuner with 70 channels which are detented and indicated just like VHF channels.
- A VHF Hi Gain Solid State Tuner.
- AC Powered.
- 90 Day Warranty.

Demonstrate the **SUBSTITUNER** to your customers and show improved reception with their TV sets.

You may place your order through any of the Centers listed below.

PROVIDES YOU WITH A COMPLETE SERVICE FOR ALL YOUR TELEVISION TUNER REQUIREMENTS.

REPAIR

VHF OR UHF ANY TYPE (U.S.A. ONLY) \$10.95
UHF/VHF COMBINATION (U.S.A. ONLY) \$17.95

MAJOR PARTS AND SHIPPING CHARGED AT COST

- Fast, efficient service at our conveniently located Service Centers.
- All tuners are ultrasonically cleaned, repaired, realigned, and air tested.

REPLACE

UNIVERSAL REPLACEMENT TUNER \$13.95 (U.S.A. ONLY)

- This price buys you a complete new tuner built specifically for this purpose.
- All shafts have a maximum length of 10 1/2" which can be cut to 1 1/2".
- Specify heater type parallel and series 450 mA or 600 mA.

CUSTOMIZE

- Customized tuners are available at a cost of \$14.95 and up (U.S.A. Only).
- Send in your original tuner for comparison purposes to any of the centers listed below.



WATCH US
GROW

HEADQUARTERS	BLOOMINGTON, INDIANA 47401	537 South Walnut Street	Tel. 812/334-0411
ALABAMA	BIRMINGHAM, ALABAMA 35212	5623 1st Avenue North	Tel. 205/592-9150
ARIZONA	TUCSON, ARIZONA 85713	1528 South 6th Avenue	Tel. 602/791-9243
CALIFORNIA	NORTH HOLLYWOOD, CALIF. 91601	10654 Magnolia Boulevard	Tel. 213/765-2720
	SAN MATEO, CALIF. 94402	600 S. Amphlett Boulevard	Tel. 415/448-3259
	MODESTO, CALIF. 95351	123 Phoenix Avenue	Tel. 209/471-6651
FLORIDA	TAMPA, FLORIDA 33606	1505 Cypress Street	Tel. 813/531-0824
	FT. LAUDERDALE, FLORIDA 33309	3516 N.W. 10th Avenue	Tel. 305/568-4882
GEORGIA	ATLANTA, GEORGIA 30310	646 Evans Street S.W.	Tel. 404/525-2252
ILLINOIS	URBANA, ILLINOIS 61801	906 E Main Street	Tel. 217/248-2052
	SKOKIE, ILLINOIS 60076	5140 West Brown Street	Tel. 312/475-0230
INDIANA	INDIANAPOLIS, INDIANA 46204	742 West St. Clair Street	Tel. 317/435-3493
KENTUCKY	LOUISVILLE, KENTUCKY 40205	2244 Taylorsville Road	Tel. 502/452-1191
LOUISIANA	SHREVEPORT, LOUISIANA 71104	2428 Southern Ave.	Tel. 318/212-3027
MASSACHUSETTS	SPRINGFIELD, MASSACHUSETTS 01108	405 Dickinson Street	Tel. 413/786-8206
MISSOURI	ST. LOUIS, MISSOURI 63132	9577 Page Avenue	Tel. 314/425-0633
NEVADA	LAS VEGAS, NEVADA 89102	1412 Western Avenue	Tel. 702/484-4235
NEW JERSEY	TRENTON, NEW JERSEY 08638	1139 Pennsylvania Avenue	Tel. 609/383-0999
	JERSEY CITY, NEW JERSEY 07307	547-49 Tonawanda Avenue, Hwy 1 & 9	Tel. 201/735-3730
NEW YORK	ROCHESTER, NEW YORK 14615	37 Pullman Avenue	Tel. 716/441-9180
NORTH CAROLINA	GREENSBORO, NORTH CAROLINA 27405	2914 East Market	Tel. 919/273-6276
OHIO	CLEVELAND, OHIO 44109	4525 Pearl Road	Tel. 216/741-2314
OREGON	PORTLAND, OREGON 97210	1732 N.W. 25th Ave., P.O. Box 10141	Tel. 503/225-9059
PENNSYLVANIA	PITTSBURGH, PENNSYLVANIA 15209	51 Grant Avenue	Tel. 412/421-4004
TENNESSEE	MEMPHIS, TENNESSEE 38114	315 Barron Avenue	Tel. 901/456-2355
TEXAS	DALLAS, TEXAS 75276	11540 Garland Road	Tel. 214/321-8413
CANADA	ST. LAURENT, QUEBEC H4N-2L7	305 Decarie Boulevard	Tel. 514/748-8803
	CALGARY, ALBERTA T2H-1Y3	P.O. Box 5823, Stn. A	Tel. 403/241-0971

IF YOU WANT TO BRANCH OUT INTO THE TV TUNER REPAIR BUSINESS, WRITE TO THE BLOOMINGTON HEADQUARTERS ABOUT A FRANCHISE.

CIRCLE 49 ON FREE INFORMATION CARD

LETTERS

continued from page 14

2) My tests, although not as sophisticated as those of an engineer, have all proved positive. During WFBR's test authority, I had two radios installed in my car and set them to the upper and lower sidebands. I drove the entire prime signal coverage area to test for any signal difficulty. There was none and the separation was maintained.

3) I drove the same route listening to mono to ascertain any difference in apparent loudness and comparison to other stations. There was none.

4) I had the engineers at WFBR switch

from mono to stereo and back again (while listening in mono with the tuner in the center position) to see if there was any interference or effect on the regular single-radio system. I found there was none.

5) I checked to see if there was any interference with any near-by station on the dial or any splatter. There was none.

6) All of the tests that I conducted proved to me that the system is compatible with current broadcast requirements.

7) In my own mind, I question FCC authority in this matter. A broadcaster is authorized to broadcast material over a commercial frequency. He must meet certain specifications and broadcast with-

in the guidelines set by the Rules and Regulations of the FCC. Since the Kahn System has no effect on these specifications and does not change them in any manner, I see no reason for FCC involvement, thus I see no reason to deny this petition.

8) Tuning to the sidebands is no problem and takes no special education. It is as simple to do as changing from one radio station to another.

9) An adaptor could easily be made for stereo tuning. However, the beauty of the Kahn System is that there is no need for the radio listener to run out and buy a new radio. If he wishes to continue listening to a radio station in the mono mode, he may continue to do so. If he has two radios and desires to listen in stereo, he may do so. If he prefers to buy a new receiver with the stereo tuner, and the manufacturers decide to build it, he may do so.

With all of these plus factors, it is hard for me to see why the FCC or any other body would even hesitate to approve use of the Kahn System. It is cheap to install for the broadcaster. It is easily adaptable to present equipment. It opens the vista of stereo broadcasting and listening to people who can't afford the luxury of buying new equipment.

In my opinion it is the duty of the Commission to afford AM broadcasters the right to equally compete with their FM counterparts.

Kahn Communications has followed the proper procedure by placing its request with the FCC rather than an ad-hoc committee.

Delayed action smacks of politics and corporate jealousy. It also deprives the public of present United States technology. It discourages the private individual from making contributions to our society.

Restrictive and delayed action is never positive action.

NO SYSTEM should be considered unless it is 100 percent compatible with today's AM broadcasting codes.

This letter is being submitted to the Commission on a personal basis by me as a citizen and taxpayer. I have no financial interests in Kahn Communications, Inc., WFBR, or any manufacturing, broadcasting or media-related industries.

Respectfully submitted,
NORMAN H. BROOKS
Brooklandville, MD

HELP!

I am an ardent but occasional reader of your fine magazine. However, it is not regularly available in this country at local stores. Hence I am requesting the help of some of your readers who would not mind to do a good turn to a not so well placed member of their technical fraternity. I would like someone to send me copies of **Radio-Electronics** magazine after they've finished using them.

I would also like to correspond to some of your readers who are interested in the exchange of small electronic components not readily available in this country, for Indian currencies.

V. N. SURENDRAN
Southern College of
Engineering and Technology
Chalakudi-680307, India

Checklist of Books for the Libraries of Technicians, Hobbyists & Students

BRAND NEW BOOKS—JUST PUBLISHED!

- Master Transistor IC Substitution Handbook. 504 p. \$7.95
- Servicing Medical & Biomedical Equipment. 336 p. \$8.95
- Model Railroad Electronics. 294 p. 224 il. \$5.95
- Linear IC Applications Handbook. 280p. \$6.95
- Broadcast Engrg. Maint. Hdbk. 532 p. 235 il. \$19.95
- Complete Hdbk of Locks, Locksmithing. 392 p. 348 il. \$6.95
- Practical Solid-State DC Power Supplies. 196 p. 151 il. \$6.95
- Optoelectronics Guidebk.—with tested projects. 196 p. \$5.95
- Transistor Ignition Systems. 252 p. 162 il. \$5.95
- TV Lighting Handbook. 228 p. 261 il. \$12.95
- How to Repair Home Kitchen Appliances. 294 p. 205 il. \$5.95
- Fun With Electronics. 140 p. 86 il. \$2.95
- Talk-Back TV. Two-Way Cable Television. 238 p. 64 il. \$5.95
- Understanding Use Modern Signal Generators. 294 p. \$6.95
- 106 Easy Electronic Projs. Beyond Transistors. 224 p. \$5.95
- Using Modern Electr. Serv. Test Eqp. 252 p. 177 il. \$5.95
- Mathematics Unraveled—Commonsense Approach. \$6.95
- Master Tube Substitution Handbook. 322 p. 548 il. \$4.95
- Modern Guide to Digital Logic. 294 p. 222 il. \$6.95
- VHF/UHF Fire, Police, Ham Scanners Man. 250 p. 114 il. \$6.95
- DP AMP Circuit Design & Applications. 280 p. 239 il. \$6.95
- Master Hdbk of Digital Logic Appl. 392 p. 287 il. \$7.95
- CET License Handbook 2nd ed. 448 p. 381 il. \$8.95
- The Electronic Musical Instr. Manual. 210 p. 385 il. \$6.95
- Microprocessor Microprogramming Hdbk. 294 p. 176 il. \$6.95
- Sourcebook of Electronic Organ Circuits. 168 p. 101 il. \$4.95
- Build Your Own Working Robot. 238 p. 83 il. \$5.95
- Car's Handbook of Simple Hobby Projs. 168 p. 114 il. \$3.95
- Fire & Theft Security Systems 2nd ed. 192 p. 114 il. \$5.95
- How to Repair Home Laundry Appliances. 280 p. 137 il. \$5.95
- Piloting, Navigation & Pocket Calculator. 392 p. 233 il. \$8.95

DO IT YOURSELF: AUTOMOTIVE & APPLIANCES

- How to Make Your Own Built-In Furniture. 336 p. 758 il. \$5.95
- Homeowner's Handy "Do-It" Manual. 280 p. 84 il. \$7.95
- Building Model Ships From Scratch. 378 p. 84 il. \$7.95
- Homeowner's Guide to Saving Energy. 196 p. 183 il. \$5.95
- Customizing Your Van. 192 p. 150 il. \$3.95
- The Woodworker's Bible. 434 p. 1151 il. \$5.95
- Dog Owner's Medical Manual. 252 p. 237 il. \$5.95
- How to Train a Watchdog. 224 p. 45 il. \$5.95
- Motorcycle Repair Handbook. 392 p. 260 il. \$6.95
- Step-By-Step Guide: Carburetor Tuneup/Overhaul. 224 p. \$4.95
- Complete Hdbk of Model Railroadng. 350 p. 238 il. \$6.95
- Homeowner's Guide to Solar Heating/Cooling. 196 p. \$4.95
- Do-It-Yourselfer's Guide: Home Plan Constr. 236 p. \$4.95
- Step-By-Step Guide to Brake Servicing. 238 p. 248 il. \$4.95
- Step-By-Step Guide: Chrysler Eng. Maint. Rpr. 256 p. \$4.95
- Subcontract Your House. Bible Hobby Projs. 196 p. 63 il. \$4.95
- Auto Electronics Simplified. 256 p. 202 il. \$5.95
- The Complete Auto Electric Handbook. 210 p. 139 il. \$5.95
- Concrete & Masonry. 392 p. 213 il. \$5.95
- Practical Home Constr. Carpentry Hdbk. 448 p. 180 il. \$5.95
- How to Repair Diesel Engines. 308 p. 237 il. \$5.95
- Central Heating/Air Cond. Repair Guide. 320 p. 285 il. \$6.95
- Small Appliance Repair Guide—Vol. 2. 210 p. 119 il. \$4.95
- Elect. Wiring/Lighting For Home/Office. 204 p. 155 il. \$4.95
- How to Repair Small Gasoline Engines. 2nd Ed. 392 p. \$6.95
- How to Repair Home/Auto Air Cond. 208 p. over 100 il. \$4.95

ELECTRONICS TECHNOLOGY/COMPUTERS/CALCULATORS

- Modern Electronics Math. 686 p. 424 il. \$9.95
- Master Hdbk of 1001 Prac. Electr. Circ. 602 p. 1250 il. \$9.95
- Impedance. 196 p. 90 il. \$5.95
- Intro to Medical Electronics-2nd ed. 320 p. 126 il. \$7.95
- Computer Programming Handbook. 518 p. 114 il. \$8.95
- Computer Technician's Handbook. 480 p. over 400 il. \$5.95
- Microelectronics. 266 p. 228 il. \$5.95
- Switching Digital Electronics. 218 p. 117 il. \$4.95
- Basic Regulators Power Supplies. 252 p. 128 il. \$6.95
- Adv. Appl. for Pocket Calculators. 304 p. 275 il. \$5.95
- Tower's Intern. Transistor Selector. 140 p. (7" x 10") \$4.95
- Electr. Conversions. Symbols/Formulas. 224 p. 252 il. \$4.95
- Effective T'shooting with EVM/Scop. 238 p. 185 il. \$5.95
- Getting the Most Out of Electronic Calculators. 204 p. 281 il. \$4.95
- Aviation Electronics Handbook. 406 p. 227 il. \$8.95
- How to Test Almost Everything Electr. 160 p. 144 il. \$3.95
- Digital Logic Electronics Handbook. 308 p. 226 il. \$6.95
- Modern Applications of Linear IC's. 276 p. 301 il. \$9.95
- 10-Minute Test Tech. For PC Svcs. 216 p. 114 il. \$4.95
- Electr. Unraveled—New Commonsense Approach. 228 p. \$5.95
- How to Tshoot/Repair Electr. Test Eqp. 252 p. 143 il. \$6.95
- Understanding Using the Oscilloscope. 272 p. 170 il. \$5.95
- Industrial Electr. Principles & Practice. 416 p. 380 il. \$8.95
- Dictionary of Electronics. 420 p. 487 il. \$4.95

COLOR TV TROUBLESHOOTING

- Color TV Trouble Facts—Probs Sols 3rd ed. 434 p. \$5.95
- Solid-State Color TV Photo Symp. Guide. 224 p. 169 il. \$5.95
- Beginner's Guide to TV Repair. 176 p. 50 il. \$4.95
- T'shooting With the Dual-Trace Scope. 224 p. 252 il. \$5.95
- TV Troubshooter's Hdbk—3rd ed. 448 p. over 300 il. \$4.95
- Color TV Case Histories Illustrated. 238 p. 219 il. \$5.95
- TV Schematics: Read Between the Lines. 252 p. 188 il. \$5.95
- Logical Color TV Troubleshooting. 240 p. 151 il. \$5.95

- TV Bench Servicing Techniques. 228 p. 177 il. \$4.95
- Modern Radio Repair Techniques. 260 p. 36 il. \$4.95
- How to Interpret TV Waveforms. 256 p. 250 il. \$4.95
- All-in-One TV Alignment Handbook. 304 p. 145 il. \$5.95
- TV Tuner Schematic/Servicing Manual. 224 p. 287 il. \$6.95
- How to Use Color TV Test Instruments. 256 p. 230 il. \$5.95
- Home-Call TV Repair Guide. 144 p. 20 il. \$3.95
- Pinpoint TV Troubles in 10 Minutes. 327 p. 394 il. \$5.95

COMMUNICATIONS & HAM RADIO

- CB Schematic Svcing. Manuals each 200 p. \$5.95. Vol 1 Kris Brown. Hy-gain. Pannoy's. Vol 2 Taaberry. Unimetrics. Pearce-Simpson. Siltronix. Vol 3 E.F. Johnson. SBE-Linear. Sonar. Royce. Vol 4 Pace Fanon-Courier. \$7.95
- 2nd Class FCC Encyclopedia. 602 p. 445 il. \$7.95
- Complete Shortwave Listener's Hdbk. 288 p. 101 il. \$6.95
- CB Radio Operator's Guide—2nd ed. 256 p. 139 il. \$5.95
- How to Hear/Speak CB in a Short-Short. 172 p. 85 il. \$3.50
- Pictorial Guide to CB Radio Install/Rpr. 256 p. 304 il. \$5.95
- Practical CB Radio T'shooting & Repair. 238 p. 108 il. \$5.95
- Complete FM 2-Way Radio Hdbk. 294 p. 111 il. \$6.95
- Amat. FM Conversion/Constr. Projs. 256 p. 187 il. \$5.95
- Best Annc'r. 3rd Class FCC Study Guide. 168 p. 19 il. \$3.95
- How To Be A Ham—Incl. Latest FCC Rules. 192 p. 25 il. \$3.95
- Commercial FCC License Handbook. 444 p. 150 il. \$5.95
- The 2-Meter FM Repairer Circuits Hdbk. 312 p. 194 il. \$6.95
- RTTY Handbook. 320 p. 230 il. \$5.95
- Citizens Band Radio Service Manual. 228 p. 84 il. \$6.95
- AMATEUR RADIO STUDY GUIDES: Novice \$5.95 General \$7.95 Advanced \$5.95 Extra \$5.95 Incentive \$4.95

HOBBY ELECTRONICS

- How to Read Electronic Circuit Diagrams. 192 p. 140 il. \$4.95
- 21 Simple Trans. Radios You Can Build. 140 p. 122 il. \$3.95
- Basic Electricity/Beginning Electronics. 252 p. 191 il. \$5.95
- Radio Control for Models. 350 p. 417 il. \$6.95
- MOSFET Circuit Guidebook. 196 p. 104 il. \$4.95
- Prac. Circuit Design for the Experimenter. 196 p. 119 il. \$4.95
- 111 Digital & Linear IC Projects. 210 p. 275 il. \$5.95
- Radio Astronomy for the Amateur. 252 p. 96 il. \$5.95
- Build-It Book of Mini Test Meas. Instr. 238 p. 151 il. \$4.95
- RF & Digital Test Eqp. You Can Build. 252 p. 217 il. \$5.95
- Miniature Projects For Electr. Hobbyists. 168 p. 77 il. \$3.95
- Practical Triac/SCR Projs. For The Exp. 192 p. 146 il. \$4.95
- Integrated Circuits Guidebook. 196 p. 119 il. \$5.95
- Solid-State Circuits Guidebook. 252 p. 227 il. \$5.95
- Electronics For Shutterbugs. 204 p. 109 il. \$5.95
- Prac. Test Instruments You Can Build. 204 p. 157 il. \$4.95
- How to Build Solid-State Audio Circuits. 320 p. 190 il. \$5.95
- Radio Electronics Hobby Projects. 192 p. 214 il. \$4.95
- Handbook of IC Circuit Projects. 224 p. 136 il. \$4.95
- Solid-State Projs. for the Experimenter. 224 p. 228 il. \$4.95
- Electronic Experimenter's Guidebook. 182 p. 86 il. \$4.95
- 125 One-Transistor Projects. 192 p. 125 il. \$4.95
- 64 Hobby Projects for Home & Car. 192 p. 159 il. \$4.95

AUDIO, Hi-Fi & ELECTRONIC MUSIC

- Electronic Music Circuit Guidebook. 224 p. 180 il. \$6.95
- Q & A About Tape Recording. 264 p. 102 il. \$5.95
- Handbook of Multichannel Recording. 322 p. 196 il. \$7.95
- Auto Stereo Service & Installation. 252 p. 245 il. \$5.95
- Srv. Cassette & Cartridge Tape Players. 294 p. 196 il. \$6.95
- Experimenting With Electronic Music. 180 p. 103 il. \$4.95
- Cassette Tape Recorders. How Work/Care/Repair. 204 p. \$4.95
- Acoustic Techniques for Home & Studio. 224 p. 168 il. \$5.95
- Pictorial Guide to Tape Recorder Rprs. 256 p. 320 il. \$4.95
- How to Repair Musical Instrument Svcs. 288 p. 50 il. \$5.95
- Jap. Radio. Record. Tape Player Srvcs. Manual. 228 p. \$6.95
- Servicing Electronic Organs. 196 p. 158 il. \$7.95
- Tape Recording for Fun & Profit. 224 p. over 200 il. \$5.95

ALL INFORMATION IN THIS CHECKLIST IS BASED ON CURRENT PUBLICATIONS

Each vol. has complete service data, parts lists, full-size schematic and all other info needed. Each 5 1/2" x 11". 196 pgs. Each only \$5.95 unless marked. COLOR TV. Adm. Vol. 1 Vol. 2 \$6.95 GE Vol. 1 Vol. 2 Jap. Vol. 1 Vol. 2 \$4.95 Vol. 3 \$4.95 Vol. 4 Vol. 5 Magnavox Vol. 1 \$4.95 Vol. 2 \$4.95 Vol. 3 Airline Mot. Vol. 1 \$4.95 Vol. 2 Philco RCA Vol. 1 Vol. 2 Vol. 3 Vol. 4 Vol. 5 Sears Serv. Modular Recr. Vol. 1 \$6.95 Vol. 2 \$4.95 Sylvania Vol. 1 Vol. 2 Toshiba Zenith Vol. 1 Vol. 2 Vol. 3 Vol. 4 B&W TV: Adm \$7.95 GE \$7.95 Jap. \$6.95 Mag. \$4.95 Mot. \$4.95 Philco \$4.95 RCA \$7.95 Sylvania \$4.95 Zenith \$7.95

NO RISK COUPON—MAIL ENTIRE AD

TAB BOOKS Blue Ridge Summit, Pa. 17214
Please send me books checked above.

I enclose \$_____ send postpaid
 Please invoice on 10-day FREE trial

Name _____ Phone _____

Company _____

Address _____

City _____ State _____ Zip _____

SAVE POSTAGE by remitting with order. Foreign add 10%. Pa. residents add 6%. RE-27

RADIO-ELECTRONICS

GC CO-PHASED SYSTEMS...

COMPARED TO OURS, THE OTHERS CAN'T CUT-IT!

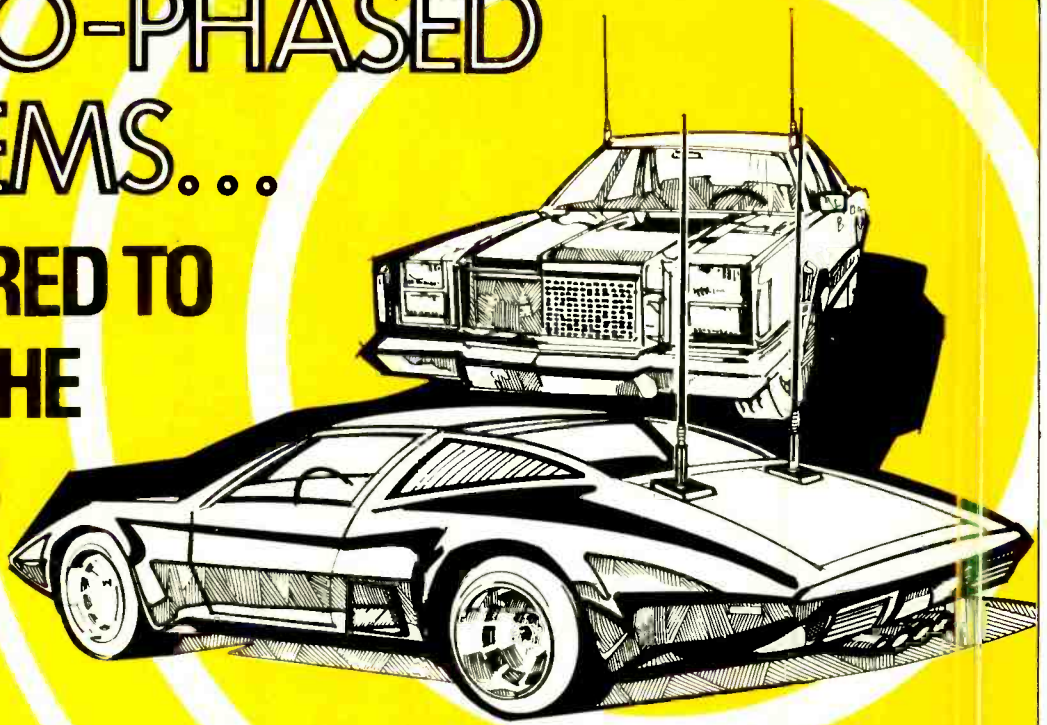

Why?





Because unlike all others, GC Co-Phased Systems feature Mixer-Balun Circuitry (Pat. Pend.). This unique GC design allows you to cut the cables to any desired length with no detrimental affect upon the performance of your system. You maintain a perfect match with no unnecessary cable to hide. So if you're buying a co-phased system, ask for GC. If you don't, we hope you won't mind holding all the extra cable on your lap.

SEE ALL THE GC CITIZENS BAND ACCESSORIES AT YOUR FAVORITE CB DEALER!

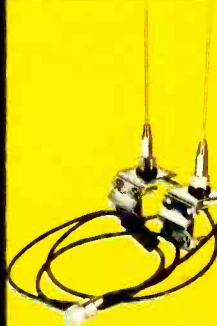

EXCLUSIVE!

GC Co-Phase Mixer—Balun Circuitry (Pat. Pend.). Allows you to cut either cable to any desired length and still be assured of impedance match!

		
UPSTART 21" Center Loaded Mirror/Gutter Clip-On Cat. No. 18-2052	MARAUDER 50" Center Loaded Mirror Mounting Cat. No. 18-2047	INTERCEPTOR 46" Base Loaded Trunk Mounting Cat. No. 18-2029
		
INTERCEPTOR 46" Base Loaded Mirror Mounting Cat. No. 18-2030	GRABBER 48" Top Loaded Trunk Mounting Cat. No. 18-2006	GRABBER 48" Top Loaded Mirror Mounting Cat. No. 18-2007



GC ELECTRONICS

DIVISION OF HYDROMETALS, INC. ROCK FORD, ILLINOIS 61101 U.S.A.



CIRCLE 1 ON FREE INFORMATION CARD

www.americanradiohistory.com

HEATHKIT®

Practical projects for the "Inside" season! Special sales and offers too!

WINTER, 1977

Digital Clocks and Weather Monitors —
See pages 2, 8, 9

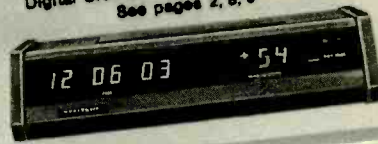

NEW — High-Performance
3-Way Speaker System
See page 36

NEW — Universal
Color TV Game
See pages 3, 85

NEW — "Touch Control"
Light Switch
See pages 77, 98

Amateur Radio Equipment —
See pages 64-75



NEW — Two-Way
Freezer Alarm
See pages 77, 96

Stereo and 4-Channel Components — See pages 25-41



Automotive Accessories —
See pages 15-23



Color and B & W TV's — See pages 85-91



Self-study
Electronics
Courses —
See pages
79, 92-94

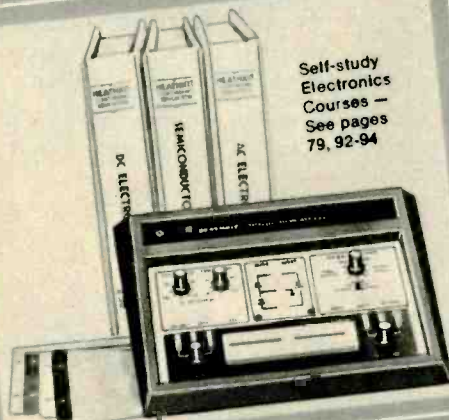

Test Instruments —
See pages 42-47, 52-63

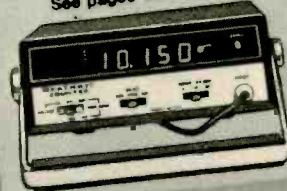

MAIL ORDER CAT.

"Heath" and "Heathkit" are registered trademarks of Hk.

© 1976 Heath Company
See Index on page 3

FREE!

Some of the most exciting electronic kits ever to come along are described in this NEW Heathkit Catalog.

NEW! HW-2036 Synthesized 2-meter Amateur Radio Transceiver.

Our finest 2-meter unit ever, with all the operating convenience and versatility you need for reliable 2-meter communications. Features complete offset capability and a built-in continuous tone encoder to access repeaters, plus new performance specifications that set an industry standard.

NEW! AR-1515 Stereo FM-AM Receiver.

Outstanding specifications and performance make the AR-1515 receiver the "heart" of any truly sophisticated stereo system. 70 watts, minimum RMS, per channel into 8 ohms with less than 0.08% total harmonic distortion from 20-20,000 Hz. Plus digital frequency readout and advanced styling others will be sure to copy.

NEW! GR-2001 Computerized Color TV.

The most convenient color TV system ever — you "program" it to change channels when you want. You can sequence an entire evening's viewing, then just sit back and relax. You can also "program" children's viewing so they watch only what you want them to watch. You can even have the GR-2001 automatically rotate your outdoor antenna for the best reception from each station. A truly sensational color TV breakthrough!

PLUS nearly 400 other superb, easy-to-build, money-saving products. You'll find a complete line of digital electronic clocks and weather instruments that give you important information "by the numbers" and with

electronic accuracy. Items for your car, home or office including an exciting combination clock/indoor-outdoor temperature monitor with a special temperature alarm.

Our self-study courses are now in use by the thousands! A really effective and low-cost way to teach yourself about electronics for fun, for knowledge, or for profit. We also have a wide selection of popular books covering almost everything in electronics.

There are many more exciting products to read about too! Home convenience items like a practical freezer alarm, a touch-control light switch, intercoms and a unique doorbell that lets you program a tune of your choice. Automotive instruments and accessories that help you keep your car running right for top performance and economy. Marine equipment that will make you a better boater and fisherman. Model aircraft Radio Control gear to give you championship performance. Security systems to protect your home and family. And of course, our world-famous Amateur Radio equipment and test and service instruments.

These are among the nearly 400 quality, fun-to-build kits described in this new Heathkit catalog. Kits for every interest. All with the world-famous Heathkit assembly manual — a step-by-step instruction guide that makes kitbuilding easy and leaves nothing to chance. And all backed by our "We won't let you fail" promise. Find out about the satisfaction, savings and FUN of kitbuilding.

Send for your FREE copy today!

HEATH		Heath Company	
Schlumberger		Benton Harbor, Michigan 49022	
Please send me my FREE Heathkit Catalog.		Send a FREE Catalog to my friend.	
I am not on your mailing list.		Dept. 20-26	
Name _____	Dept. 20-26	Name _____	Dept. 20-263
Address _____		Address _____	
City _____ State _____		City _____ State _____	
Zip _____		Zip _____	

CL-624

CIRCLE 100 ON FREE INFORMATION CARD

www.americanradiohistory.com

*** PUT THE "IGNITION OF THE FUTURE" ON YOUR CAR TODAY!**

MODERNIZE and Bring Your Car "UP-TO-DATE" with the MOST EFFICIENT Ignition ever invented!

*** End "Tune-Up" Problems FOREVER**
caused by Points and Condensor

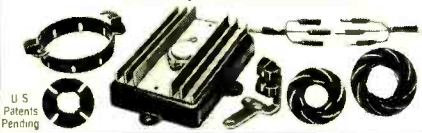

U.S. Patents Pending

ALLISON XR-700

with the Exclusive...Solid-State Voltage Regulator.

The ONLY Ignition System that has COMPLETELY overcome the Problems that have baffled the Auto Industry for Years!

SO RELIABLE (99.9+%)... SO PERFECTED... that it will soon be STANDARD on most Future New Cars!

ALLISON Rated #1 by Official Testing Laboratory as the BEST "Fuel Saving" Ignition System of ALL the Different Ignition Systems Tested!

* The "XR-700" is a COMPLETELY NEW Ignition System employing the Most Advanced Technology, that replaces the inefficient Points and Condensor with an infrared Light Beam to Trigger the Latest type of Solid-State Power Components. Once installed... "XR-700" has NO moving Parts to wear out or adjust. It works without Friction or wear. Not affected by Dirt, Oil, Moisture, Vibration or extreme Engine Temperatures! **RUGGED and RELIABLE!**

* The "XR-700" is engineered to **OUTLAST YOUR CAR!**

* The "XR-700" produces the MAXIMUM "High Energy" Long Duration Spark... from your present car's Ignition Coil. This permits the Positive Firing of Spark Plugs, even under the most Adverse conditions. Also, Eliminates "Engine Misfire," resulting in more COMPLETE COMBUSTION! Thus you get IMPROVED Fuel Mileage, a HIGHER Performance Level... keeps Plugs FROM FOULING and gives LONGER Plug Life!

Customers Report:

★ "IT MORE THAN PAYS FOR ITSELF!"

- ★ INCREASES Gas Mileage up to 30%!
- ★ SAVES Money on Costly "Tune-Ups"!
- ★ Gives Continuous PEAK Performance!
- ★ QUICKER Starting in Any Weather!
- ★ Smoother Running... Faster Acceleration!
- ★ Plugs Last Up to 4-Times LONGER!

* Reliability PROVEN in Millions of Customer Miles to be so exceptionally GOOD... that every "XR-700" has a LIFETIME WARRANTY! FREE Repair or Replacement for as long as you OWN the Unit!... and even if you CHANGE Cars, Allison will supply you the necessary PARTS to fit ANY Point-Type Distributor... FREE! (Include \$2 for Postage & Handling).

* FITS ALL CARS, Domestic & Foreign. 4, 6 or 8-Cylinder.

★ DO-IT-YOURSELF... EASY INSTALLATION!

The New "XR-700" is Completely Factory Assembled... Thoroughly TESTED! New Precision "Drop-in" Mounting Bracket, with color-coded, "Snap-Together" wire connections. No Distributor Removal necessary. Protected against Incorrect Hook-up!

● Thousands sold at \$59.95 ● ONLY

NOW! Allison's Production Technology offers you the same Premium Quality XR-700 at this SPECIAL LOW Price... \$39.95

COMPLETE (Cal. Res. add Tax) THAT'S EVERYTHING... INCLUDING POSTAGE & INSURANCE

★ ORDER WITH CONFIDENCE... install the "XR-700", and prove to your own SATISFACTION that it is as advertised, or return it within 30 days for a FULL Refund of the Purchase Price

* SAVE! ORDER FACTORY DIRECT.

Send Check or M.O., State Car Make, Year, No. Cylinders

* MASTER CHARGE or BANKAMERICARD Card Holders: ORDER by TOLL-FREE PHONE. (800) 423-6525, Ext. 2 or Send us (1) Your Number, (2) Interbank No., (3) Exp. Date.

*** SEND for FREE BROCHURE and Comparison Sheet.**

"CB" USERS: The "XR-700" completely ELIMINATES the Major Cause of Primary Ignition Noise Interference.

* If you have already installed a "Capacitive Discharge" Ignition * Convert your "C-D" Unit to BREAKERLESS! INCREASE ITS EFFICIENCY with "XR-CO"... only \$29.95

* America's Oldest and Largest Manufacturer of Opto-Electronic Ignition Systems. ©



ALLISON AUTOMOTIVE CO.

1267 - RA, East EDNA PL., COVINA, CAL. 91722
CIRCLE 68 ON FREE INFORMATION CARD

KOMPUTER KORNER

JOHN TITUS, DAVID LARSEN, and PETER RONY*

ONE OF THE MOST IMPORTANT PROGRAMMING characteristics possessed by any digital computer, including a microcomputer, is the ability to make a decision. For a typical microcomputer, we can define a *decision* as the process of determining further action based upon the logic state of a *flag*. A *flag* is a single flip-flop that can be either set or cleared in response to operations occurring within the microcomputer system. A change of state of the flag is usually an indication that either a particular operation has been completed or that a certain condition exists as a result of a microcomputer operation. Flags can be located either internal or external to the microprocessor chip; the ones that we shall discuss in this column are the internal flags that are set or cleared in response to specific types of microprocessor instructions such as arithmetic and logical instructions.

The flags that are located within the microprocessor chip are typically associated with the *arithmetic-logic unit (ALU)*, a region within the chip where all arithmetic and logical operations are performed. In the 8080 microprocessor chip, for example, there exists five flags that indicate the following conditions:

zero flag—If the result of an arithmetic or logical operation is zero, the zero flag is set to logic 1. If non-zero, the zero flag is reset to logic 0.

sign flag—If the result of an arithmetic or logical operation is negative, the sign flag is set to logic 1. If positive, the sign flag is reset to logic 0.

parity flag—If the result of an arithmetic or logical operation has even parity, the parity flag is set to logic 1. If odd parity, the parity flag is reset to logic 0.

carry flag—If the result of an arithmetic or rotate operation has a carry of the most significant bit of the 8-bit result, the carry flag is set to logic 1. If not, the carry flag is reset to logic 0. The carry flag is reset to logic 0 after all logical operations.

auxiliary carry-flag—If the result of an arithmetic operation has a carry of bit-3 into bit-4 of the 8-bit result, the auxiliary carry flag is set to logic 1. If not, the auxiliary carry flag is reset to logic 0. The auxiliary carry flag is reset to logic 0 after most logical operations.

* This article is reprinted courtesy American Laboratories, Dr. Rony, Department of Chemical Engineering, and Mr. Larsen, Department of Chemistry, are with the Virginia Polytechnic Institute & State University. Mr. Titus is President, Tychon, Inc.

Since insufficient space is available in this column to discuss all of the above flags, we shall restrict our attention to the zero flag.

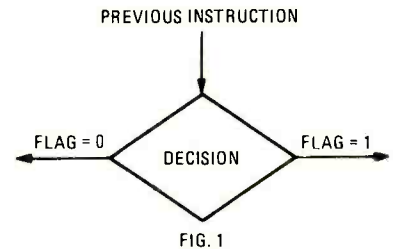
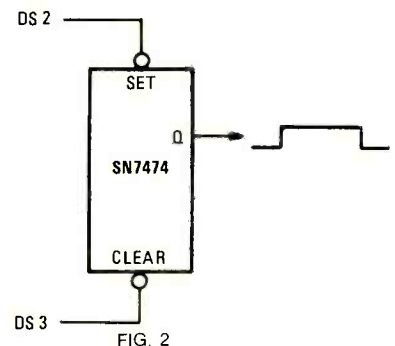

Figure 1 shows the traditional flowchart *decision symbol*. The next instruction that is executed depends upon the logic state of the flag that is associated with this specific decision. For example, consider the JNZ instruction, where JNZ means "Jump If Not Zero."

Instruction code	Mnemonic	Description
302	JNZ	If the zero flag is at logic 0, jump to the 16-bit memory address given in bytes <B2> and <B3> of this three-byte instruction. If the zero flag is at logic 1, ignore this instruction and proceed to the following instruction.

The statement, "Jump If Not Zero," refers to the 8-bit result of a preceding instruction, not the logic state of the zero flag. When this result is zero, the zero flag is set and program control passes to the next instruction.



The JNZ instruction is widely used in the creation of programmed *time-delay loops*, an *continued on page 24*

switch to Supertape®

PREMIUM QUALITY, INTERNATIONALLY SOLD
AND ACCLAIMED, MADE IN USA BY RADIO SHACK

For the ultimate in
audio recording —
5" and 7" open reels

There's no better
8-track tape — and
we run-in test every
single cartridge



High output, low noise, wide
dynamic range from cassettes
— without special bias settings

Radio Shack built one of America's most technologically advanced plants devoted exclusively to audio tape because we simply weren't satisfied with what we were getting. And millions of you weren't either, as the dramatic success of Supertape has proved.

It's made on the newest equipment and to the highest performance standard we could set. So if you haven't already, join the switch to Supertape. Let your recorder and your ears be the judge. Not our advertising. Not theirs. Try Supertape today — you can't buy a better tape for the money!



Just Say "Charge It"
at participating stores

SOLD ONLY WHERE YOU SEE THIS SIGN:

Radio Shack®

A TANDY COMPANY • FORT WORTH, TEXAS 76107
OVER 5000 LOCATIONS IN NINE COUNTRIES

example of which is provided in Table 1. In this program, both the address and instruction bytes are in octal code; it is assumed that the HI memory address byte is 000. The program first moves an 8-bit timing byte into register B. This byte, indicated by an asterisk (*) has any value between 000 and 377. The value of the byte will determine the duration of the time delay.

At LO memory address 002, a device-select pulse is generated to set the SN7474 flip-flop shown in Fig. 3. The contents of register B are then decreased by 1. The JNZ instruction immediately tests the logic state of the zero flag. If the contents of register B are not zero, the flag is at logic 0 and a jump occurs back to LO memory address 004. The DCR B and JNZ instructions are executed repeatedly until the contents of register B becomes zero, at which time the zero flag becomes logic 1. The JNZ instruction tests the flag for the last time and shifts program control to the OUT 3 instruction at LO memory address 010. This output instruction generates a device-select pulse that clears the SN7474 flip-flop. Once this has been done, the microcomputer comes to a halt.

The program shown in Table 1 generates a single output-pulse the duration of which can take any value between 0.0125 and 1.925 ms in steps of 0.0075 ms. The calculations associated with the conversion of clock cycles to pulse widths are discussed in the *Bugbook III, Microcomputer Interfacing Experiments Using the Mark 80 Microcomputer, an 8080*

TABLE 1—SIMPLE TIME-DELAY LOOP

LO memory address	Instruction byte	Mnemonic	Clock cycles	Description
000	006	MVI B	7	Move following timing byte into register B
001	*	—	—	Timing byte for register B
002	323	OUT 2	10	Generate device select pulse that sets the SN7474 flip-flop
003	002	—	—	Device code for set input to SN7474 flip-flop
004	005	DCR B	5	Decrement contents of register B by 1
005	302	JNZ	10	If zero flag is at logic 0, jump to the memory address given by the following two address bytes; otherwise, ignore this instruction
006	004	—	—	LO memory address byte
007	000	—	—	HI memory address byte
010	323	OUT 3	10	Generate device select pulse that clears the SN7474 flip-flop
011	003	—	—	Device code for clear input to SN7474 flip-flop
012	166	HLT	7	Halt the microcomputer

System (E&L Instruments, Inc., Derby, Conn., 1975). The number of clock cycles is a measure of the actual time that it takes the microcomputer to execute a single instruction or group of instructions. For a 2 MHz microcomputer, a single clock cycle has a duration of 500 ns.

The program in Table 1 and associated SN7474 flip-flop provide an example of what we mean by "the substitution of hardware by software," viz., a simple program and a single flip-flop replace a much more complicated

hardwired programmable monostable circuit. **R-E**

Thanks to you it works...
FOR ALL OF US



Advertising contributed for the public good

a revolutionary concept in kit building...
THE PROGRAMMABLE CLOCK KIT! \$29.95

SYSTEM 5000 is the first full-feature timepiece available in programmable form. After the circuit has been assembled and tested, all that is necessary is to add the appropriate switches and jumpers to easily program the system for the desired functions. The system may be expanded or reprogrammed at any time.

This represents a revolutionary concept in adaptability and flexibility. Build an Alarm/Clock/Calendar or a full feature Desk or Radio Station clock. Use the DUPLICATE TIME REGISTER to monitor GMT, another time zone, or as an elapsed timer. Add the optional relay to control AC or DC accessories. The possibilities are limited only by your imagination.

features

TIME OF DAY REGISTER • DUPLICATE TIME REGISTER • FOUR YEAR CALENDAR - month/day or day/month format • ALARM WITH SPEAKER TONE OUTPUT • ADDITIONAL ALARM - use for "his and hers" alarm or activate an accessory kit at preset time • 10 MINUTE SNOOZE & "ID" REMINDER • 3 FUNCTION ALARM OUTPUT SELECT - tone, relay, or relay then tone • ONE HOUR DOWN COUNTER • BRIGHT FLUORESCENT DISPLAY - 5" easy to read digits with AM/PM • AUTOMATIC DISPLAY DIMMING • POWER FAILURE INDICATION • 12 & 24 HOUR DISPLAY • BLINKING OR STEADY COLOR • SIMPLE FORWARD AND REVERSE TIME SETTING •

DIRECT DRIVE ELIMINATES RFI • SINGLE 9 VOLT BATTERY BACKUP • DISPLAY SECONDS CONTROL • HOLD AND RESET CONTROLS • 50/60 HZ • 700 WATT RELAY OPTIONAL

SYSTEM 5000 includes all components, 2 time setting switches, and complete assembly and programming manuals. Switches for additional functions and relay are not included but are available as options.

RELAY OPTION - \$4.00

Includes 700 watt relay and all interface components. Will control appliances, stereos, etc.

SWITCH OPTION - \$3.75

Contains 4 black SPST pushbuttons, 2 black DPDT pushbuttons, and 2 black SPST slide switches. Programs all major features.

CASE OPTION - \$11.00

Hand finished, solid walnut cabinet complete with faceplate and rear panel.

Send your check or money order today for fast delivery. Add \$1.00 per clock to cover shipping and insurance. Money back guarantee on all products if not fully satisfied. N.J. residents add 5% sales tax. Use your Master Charge or BankAmericard. Phone orders accepted.

digital concepts

DIGITAL CONCEPTS CORPORATION
249 Route 46, Saddle Brook, N.J. 07662
201/845-7101

add a new dimension to time itself with
SERIES 2000 Decorator Clocks

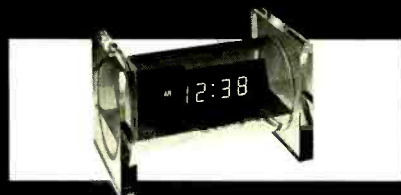

FACTORY ASSEMBLED - 1 YEAR WARRANTY
EC-2001 Solid Acrylic "Time Capsule" \$59.95
EC-2002 Acrylic & Hardwood \$49.95

A bright Fluorescent display provides easy to read numbers that brighten and dim automatically according to the light. The clear Acrylic tube with Acrylic or Hardwood end blocks gives these clocks a unique look of simple elegance. AM/PM & power failure indication. Seconds display button. 3 1/2" x 3 3/4" x 5 3/4", 50/60 HZ
Specify blue or green display, 12 or 24 hour time, and choice of Hardwood - Walnut, Zebra wood, or Rosewood.

COMPLETE KITS - 90 DAY WARRANTY
EC-2001-K Solid Acrylic NEW! \$39.95
EC-2002-K Acrylic & Hardwood SPECIAL! \$34.95

CIRCLE 74 ON FREE INFORMATION CARD

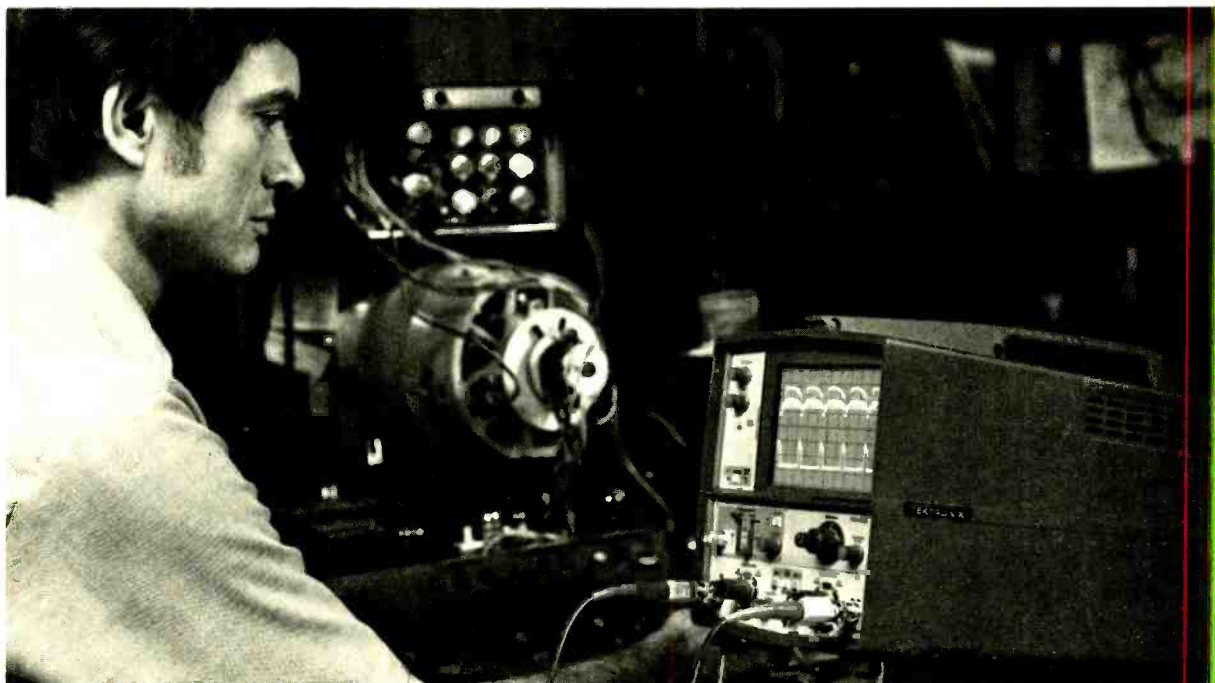

Now you can service with a TEKTRONIX Oscilloscope for as little as \$695*

Cost of service instruments is an important factor in any purchase. But so is reliability. Now T900 Oscilloscopes give you both Tektronix quality *and* reliability at prices *designed* for cost sensitive applications.

- T921—Dc to 15 Mhz; single trace,
single time base \$695*
- T922—Dc to 15 MHz; dual trace,
single time base \$850*
- T932—Dc to 35 MHz; dual trace,
single time base \$1195*
- T935—Dc to 35 MHz; dual trace,
delayed sweep time base \$1395*
- T912—Dc to 10 MHz; bistable stor-
age; writing speed to 250
cm/ms; dual trace, single time
base \$1300*

Performance to Spare

All T900 scopes feature large (8x10 cm), bright crt's; sensitivity of 2 mV/div to 10 V/div in twelve calibrated steps; regulated power supplies; and 3% accuracy. T900 Oscilloscopes are also equipped

with important convenience features; beam finder, single knob triggering, automatic selection of chopped or alternate mode, and automatic selection of tv line or frame display (except T912 Storage model). T900 scopes are compact (7x9x 19 in.) and lightweight (only 16 lb.). They are available with a full selection of accessories.

For a demonstration of any T900 Oscilloscope or a free copy of the new T900 brochure, write to Tektronix, Inc., P.O. Box 500, Beaverton, OR 97077. For immediate assistance, call (503) 644-0161, extension T900.

T900 Series the quality low cost Oscilloscopes



*All prices include 10X probes. U.S. sales price FOB Beaverton, Oregon.



TEKTRONIX®
committed to
technical excellence

CIRCLE 29 ON FREE INFORMATION CARD

www.americanradiohistory.com

Another Heathkit Color TV breakthrough..

There's never been a Color TV System like this before.

A Bold New Concept In TV

The new GR-2001 TV system is the most sophisticated, best performing color TV kit we've ever designed, but it is also much more. It is the heart of a total home viewing system — a Computer TV!

Complete Programming Capability

With its optional Programmer, this Computer TV system allows you to program your set for an entire evening's viewing. The top bank of 8 keys [1] accesses the static NMOS RAM and turns the on-screen clock display into a computer CRT readout which allows you to see your "program" as you enter it through the bank of 12 keys below the programmer panel. The selected time appears in the first four digits of the clock display, the channel number appears in the last two. First, enter the time at which you want the set to change channels. Next, enter the channel number you want. Then the memory takes over. While you sit back and relax, the Programmer automatically changes to the right channel at the right time. You can program up to 32 channel changes within two 12/24-hour periods!

Those two programming periods add extra versatility. Program the first for your daytime viewing schedule, the second for evening shows. Or, program the first for week nights, the second for weekends. You can even preselect the programs young children can watch — once the programmer is engaged, the manual keyboard is disconnected and can only be reactivated by the remote control or by pressing the correct button on the programming panel.

You can even program the set to return to manual operation at a preselected time, then resume automatic operation at another time. When the last program you want to see is over, the set can be programmed to switch to an empty channel. This will cause the screen to go blank and the on-screen readout to flash on and off indicating that it is time to turn the system off with the front panel pushbutton or optional remote control.

Convenient Remote Control

The optional wireless remote control [2] lets you adjust volume, turn the set on or off, adjust tint, activate the digital read-

out, scan up or down through the preselected channels, and turn the optional programmer on and off — all at the touch of a button. This wireless remote control has improved circuitry for greater range and reliability and is the best we've ever offered.

Random Access Tuning

The 3 x 4 keyboard [3] lets you instantly choose any of up to 16 preselected stations — up to 24 with the optional eight channel accessory. Switch from VHF to UHF, up or down, in any sequence, and be tuned in instantly without switching through empty channels. Up and down buttons on the keyboard also let you scan all the preselected stations.

Automatic Antenna Rotor Control

A Heathkit exclusive! With the optional antenna rotor control [4], you can program the GR-2001 to automatically rotate your outdoor antenna system as it changes from one channel to another, for optimum reception on every channel. No special knobs to turn, no buttons to push. You can select up to eight separate antenna headings with up to three stations per heading. It's perfect for areas where stations are in widely separated locations.

Superb Color and Sound

The TV set itself contains dozens of circuit refinements and improvements designed to give you the best picture and performance you've ever seen. The Automatic Gain Control circuit, for example, has been significantly improved to better resist airplane flutter. And since you build it yourself, you can be assured of a set that is free of mass production "glitches" that show up all too often in other sets now on the market.

Separate Audio IF Stage

The audio circuitry is probably the finest on any commercial set in the world. The sound signal has its own separate IF stage [5] that contributes to real quality audio. Audio and video muting provide smooth, silent between-channel tuning, too. You can hear the difference — especially if you

use the output jack to connect the GR-2001 to your stereo system. The built-in wide-range speaker offers excellent fidelity as well. It's one of the first sets ever to give you real hi-fi sound from a TV!

Phase-Locked-Loop Horizontal and Vertical Hold Circuits

New phase-locked-loop horizontal and vertical oscillators [6] "lock-in" on any channel for a picture that's rock-steady and stable. There are no conventional vertical and horizontal hold controls because you never need them! There are no alignment problems either, so you get consistently excellent pictures year after year.

Black-Matrix Picture Tube

The GR-2001's 25" (diagonal) ultra-rectangular picture tube [7] provides one of the brightest, sharpest pictures in the world. The tube is fully shielded to maintain outstanding color purity by eliminating stray magnetic fields.

Easy To Assemble

Though the GR-2001 is one of our more complex kits, the average person shouldn't have any difficulty in assembling it. A step-by-step illustrated manual will lead you through assembly right up to troubleshooting and testing. A test meter (included) lets you check assembly as you go, and the built-in dot generator aids in setup and service.

GR-2001 Specifications

Antenna Input Impedance: VHF: 300Ω balanced or 75Ω unbalanced. UHF: 300Ω balanced.

Hi-Fi Output: Frequency Response: ±1 dB, 50 Hz to 15 kHz.

Output Voltage: Greater than 1.0 V RMS.

Audio Output: 4Ω or 8Ω, 2 Watts.

Power Requirement: 110 to 130 Volts AC, 60 Hz, 200 Watts.

Dimensions: 29 1/8" W x 20 1/8" H x 21 3/4" D.
GR-2001 TV kit alone (chassis, picture tube and one speaker): 699.95

Heath Company, Dept. 20-261
Benton Harbor, Michigan 49022

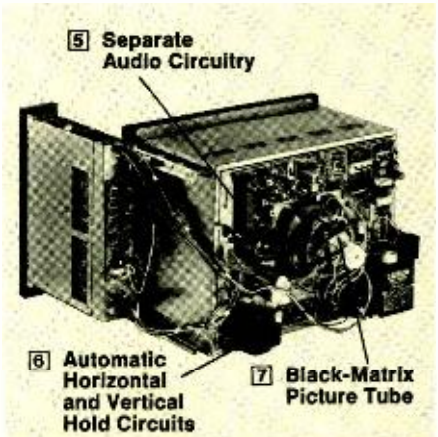
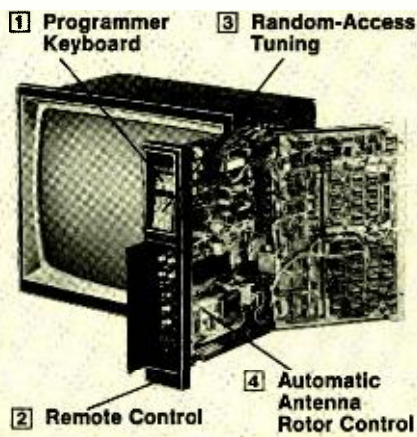

FREE Catalog of nearly 400 fun-to-build electronic kits.

HEATH
Schlumberger
Heath Company, Dept. 20-261
Benton Harbor, Michigan 49022

Please send me my FREE Heathkit Catalog.
I am not on your mailing list.

Name _____
Address _____
City _____ State _____ Zip _____
GX-328A

Prices and specifications subject to change without notice.
CIRCLE 102 ON FREE INFORMATION CARD

www.americanradiohistory.com

the world's only computerized TV system.



Simulated TV Pictures

CIRCLE 102 ON FREE INFORMATION CARD

www.americanradiohistory.com

The better the training the better you'll

Send for
FREE
illustrated
career
guide

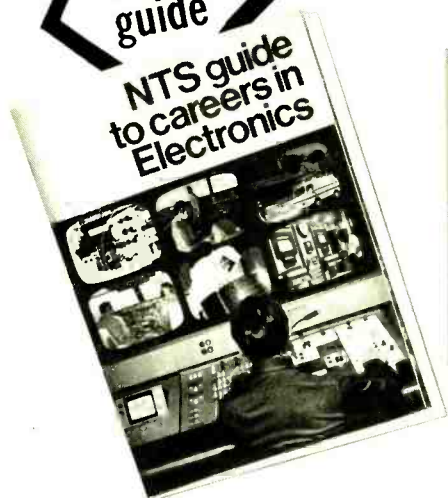

IN-CIRCUIT TRANSISTOR TESTER
COMPU-TRAINER
TROUBLESHOOTER
VOM

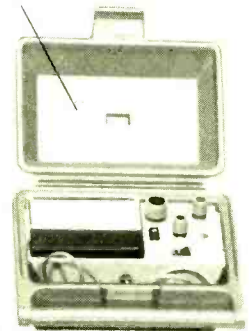
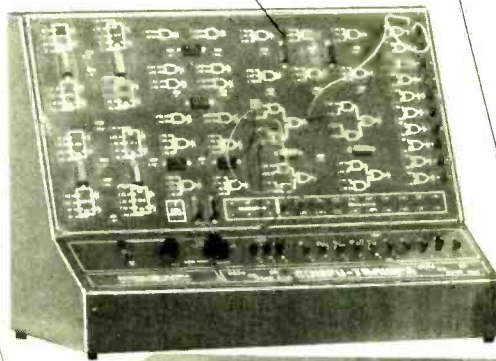

SOLID-STATE
OSCILLOSCOPE

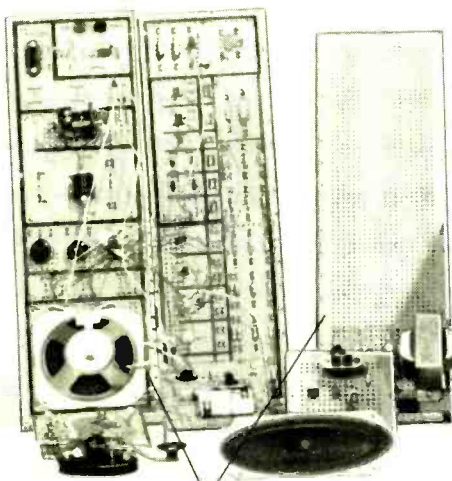

ELECTRO-LAB



(Simulated TV Reception)

As an NTS student you'll acquire the know-how that comes with first-hand training on NTS professional equipment. **Equipment you'll build and keep.** Our courses include equipment like the **NTS/Heath GR-2001 computerized color TV (25" diagonal)** with varactor diode tuning and digital read-out channel selection; (optional programming capability and digital clock avail.).

Also pictured above are other units — 5" solid state oscilloscope, vector monitor scope, solid-state stereo AM-FM receiver with twin speakers, digital multimeter, and more. It's the kind of better equipment that gets you better equipped for the electronics industry.

This electronic gear is not only designed for training; it's field-type — like you'll meet on the job, or when you're making service calls. And with NTS easy-to-read, profusely illustrated lessons you learn the theory behind these tools of the trade.

Choose from 12 NTS courses covering a wide range of fields in electronics, each complete with equipment, lessons, and manuals to make your training more practical and interesting.

Compare our training; compare our lower tuition. We employ no salesmen, pay no commissions. You receive all home-study information by mail only. All Kits, lessons, and experiments are described in full color. Most liberal refund policy and cancella-

and the equipment be equipped.

**COMPARE OUR
KITS AND LESSONS.
COMPARE OUR
TUITION.**

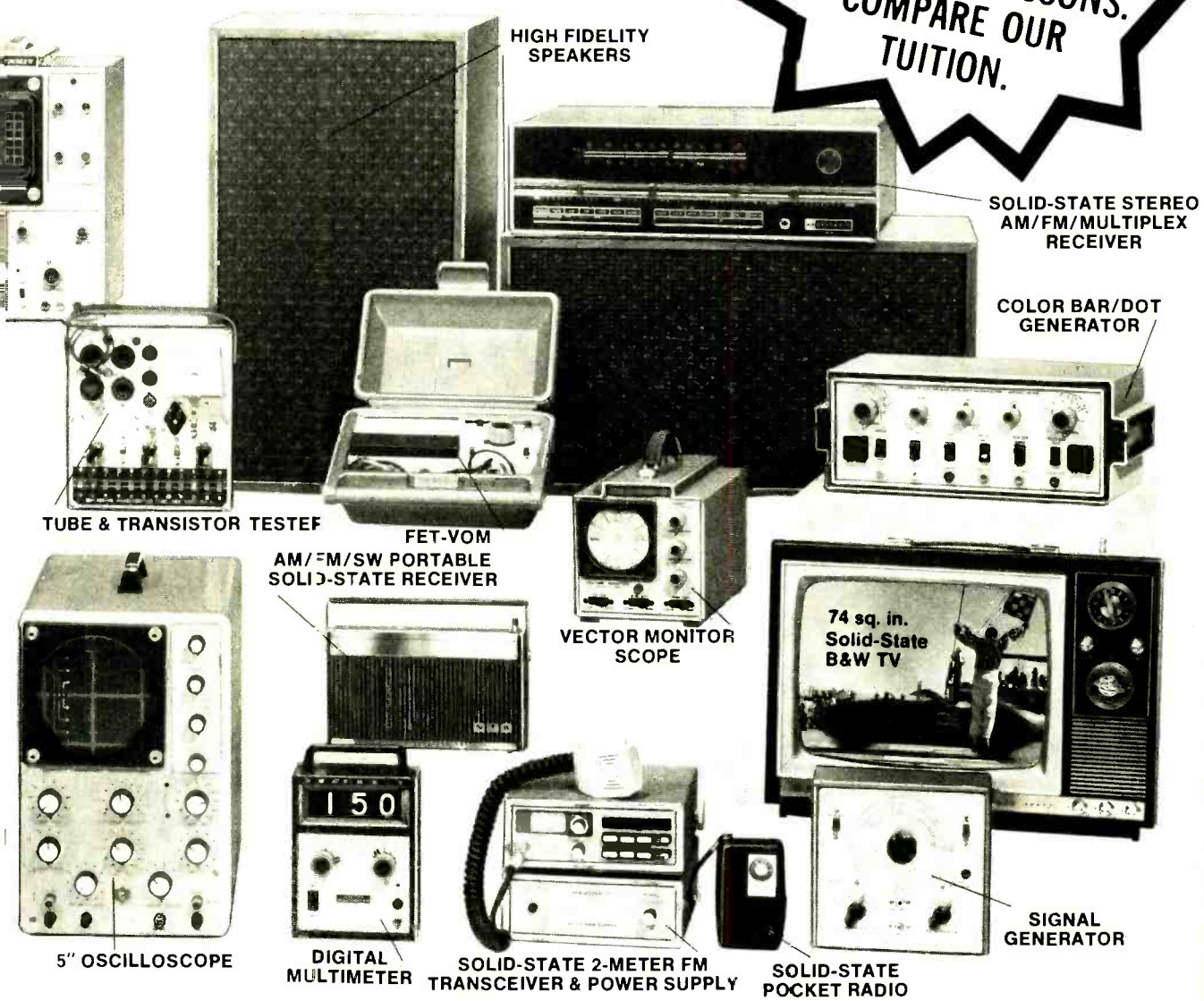

tion privileges spelled out. Make your own comparisons, your own decision. Mail card today, or clip coupon if card is missing.

NO OBLIGATION. NO SALESMAN WILL CALL

APPROVED FOR VETERAN TRAINING

Get facts on new 2-year extension

NATIONAL TECHNICAL SCHOOLS

TECHNICAL-TRADE TRAINING SINCE 1905
Resident and Home-Study Schools
4000 So. Figueroa St., Los Angeles, Calif. 90037

NATIONAL TECHNICAL SCHOOLS Dept. 206.027
4000 South Figueroa St., Los Angeles, Calif. 90037
Please send FREE Color Catalog and Sample Lesson.
NO OBLIGATION. NO SALESMAN WILL CALL.

<input type="checkbox"/> Color TV Servicing	<input type="checkbox"/> Electronics Technology
<input type="checkbox"/> B & W TV and Radio Servicing	<input type="checkbox"/> Computer Electronics
<input type="checkbox"/> Electronic Communications	<input type="checkbox"/> Basic Electronics
<input type="checkbox"/> FCC License Course	<input type="checkbox"/> Audio Electronics Servicing

NAME _____ AGE _____

ADDRESS _____ APT # _____

CITY _____ STATE _____

Please fill in Zip Code for fast service _____

Check if interested in G.I. Bill information.
 Check if interested ONLY in classroom training in Los Angeles

equipment reports

B & K Model 2040 CB Signal Generator

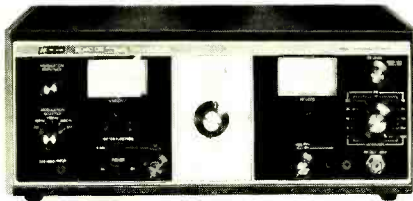

CIRCLE 82 ON FREE INFORMATION CARD

AS MANY SERVICE SHOPS ARE TOO FREQUENTLY aware, it is almost impossible to convince most CB'ers that a repair or adjustment has restored "like new" performance to their transceiver. The time spent just explaining the in and outs of sensitivity and adjacent channel rejection can eat up a good part of the profit in many CB repair jobs.

But now there's a service instrument that not only lops hours off CB service, it satisfies customers in minutes and lends itself to setting up a traffic-building "lab check-out" station in some unused corner of the shop.

For a modest fee, any service shop can now provide a complete laboratory quality check-out of any modern transceiver.

The equipment that does all this is B & K's model 2040 CB Signal Generator that is specifically designed for the test and adjustment of Class-D AM and SSB transceivers. Just looking at the front panel is almost self-explanatory as to features and service conveniences.

In the center of the front panel is the CHANNEL selector for the digitally synthesized oscillator that provides all 40 channels plus all the frequencies in-between authorized channels. For example, the dial is calibrated for Channels 11 and 12. The frequency between the two is not authorized for Class D, yet the signal generator has a dot and frequency readout for Channel 11½, so adjacent channel rejection for channels 11 and 12 can be measured. The two "channels" between Channels 22 and 23 were similarly unassigned to CB. They are *now* Channels 24 and 25 and are so indicated on the dial.

The CHANNEL selector indicates the frequency and the channel, or a dot if no channel is assigned, for every step of the selector switch.

On the right side of the front panel are the RF output controls and an associated meter calibrated in microvolts and dB. A precision shielded attenuator provides a full-scale RF output of 1 to 100,000 microvolts. An RF LEVEL control permits the output to be further reduced to 0.1 μ V. For adjacent channel and AGC measurements, the attenuator and meter are calibrated in dB as well as absolute microvolts. The RF output is available at a standard SO-239-type coaxial connector.

For service and troubleshooting there is also a 455-kHz oscillator complete with its own output control and output jacks. This oscillator can be used simultaneously with the RF signal generator.

On the left side of the front panel is a fully metered modulator and incremental frequency control. The modulator provides 400, 1000 and 2500-Hz internal modulation, or external modulation, to full 100%. The modulation amplitude is adjusted by a continuously variable control and the percent modulation is indicated directly on the meter. By "flipping" a meter function switch, the meter is set to indicate the delta frequency (incremental adjustment) of the main oscillator. A control



"FERRET" TV MINI-ANALYZER FOR FAST STEP-BY-STEP TROUBLE SHOOTING

SUB TUNER

VHF AND UHF TUNER FOR RAPID TESTING OF ALL CHANNELS. CALIBRATED GAIN ADJUSTMENTS PROVIDE FOR SIGNAL STRENGTH COMPARISON.

DIGITAL GENERATOR

CRYSTAL CONTROLLED FOR GENERATING STABLE PATTERNS WHEN CONVERGING RED, GREEN AND BLUE GUNS. IDEAL FOR LINEARITY, PIN CUSHION, CENTERING, FOCUS AND ALL PICTURE ADJUSTMENTS.

40 MHz OUTPUTS

IF SIGNALS FROM DIGITAL GENERATOR AND SUB TUNER FOR STAGE-BY-STAGE ANALYZING AND TROUBLE SHOOTING.



SG 785 \$99.95

GENERATOR SECTION

CROSS-HATCH

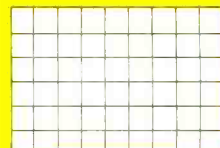

LINEARITY ADJUSTMENT

STANDARD FOR VERTICAL AND HORIZONTAL POSITIONING, PICTURE CONTRAST, IF BANDWIDTH TEST

DOT PATTERN



CONVERGENCE ADJUSTMENT

STATIC AND DYNAMIC CONVERGENCE, BEAM ADJUSTMENTS.

The VHF/UHF section of the Ferret allows direct substitution of the TV's tuner for fast, positive localizing of front end trouble.

The crystal controlled digital circuitry assures complete accuracy of both the vertical and horizontal frequencies. Accuracy is better than .005%. Output from the generator may be coupled thru the tuner section or directly to the IF-video stages. Resolution is limited only by the picture quality of the TV receiver. Operates from 105 to 125 volts 50-60Hz.

SOLD THRU DISTRIBUTORS ONLY

Please send me more information. F-2

Name _____

Address _____

Code _____



2849 FULTON STREET, BROOKLYN, NY 11207
PHONE: (212) 827-1500

CIRCLE 72 ON FREE INFORMATION CARD

www.americanradiohistory.com

You get a lot extra with Jerrold's Xtra Rated Antennas.



Jerrold
Super VU-Finder
and Paralog Plus
Antennas are now
Xtra rated to give you:

- Xtra** Ease of Installation
- Xtra** Mechanical Reliability
- Xtra** Performance

Jerrold VU-Finder and Paralog Plus Antennas have long been the performance standard of the industry. Yet, we are constantly working to advance the state-of-the-art and have now added a number of important improvements. Our antenna line is significantly better than any antennas we have ever produced. And that goes for competitive antennas too! The Xtra features found in the Super VU-Finder and Paralog Plus Antennas make them *go up faster, perform better and stay up longer.*

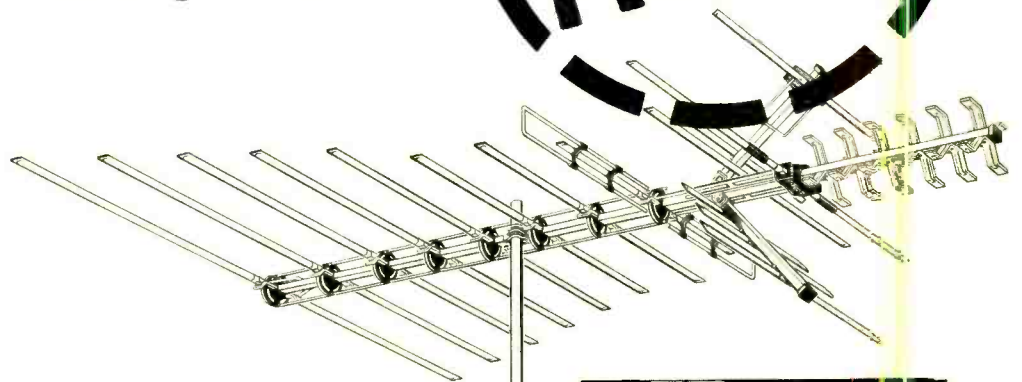

Here are a few of the features now found in Jerrold Xtra Rated Antennas.

Improved U-Bolt Assembly

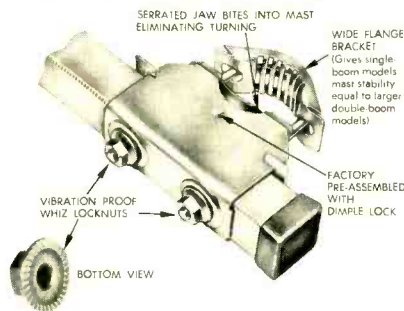

Improved Stainless Steel Terminal Screws

The no-strip stainless steel washers have longer teeth to give a better bite on current foam twin-leads, assuring excellent electrical contact. Terminal screws have also been made longer.



FM Breakaway

FM blocking elements reduce received FM up to 12 dB. To receive FM at full gain, break off the element at score mark.

Stamped Termination Bracket

The stamped termination bracket provides dc continuity and provides higher front-to-back ratio by using the rear element as a tuned reflector.



Dollar for dollar, and dB for dB, no competitive antennas match the VU-Finder and Paralog Series for ease of installation, performance and reliability.

Install a Jerrold Xtra Rated Antenna today and see the difference for yourself or write for complete details.

QDMX

JERROLD ELECTRONICS

GENERAL INSTRUMENT CORPORATION



JERROLD ELECTRONICS CORPORATION • 200 Witmer Road • Horsham, Pennsylvania 19044 • (215) 674-4800

CIRCLE 60 ON FREE INFORMATION CARD

FEBRUARY 1977

33

77

35

channel; the level of the sound carrier, which must be from 13 to 17 dBmV down to the video carrier, and so on and on. These may be checked with a field-strength meter, of course, but with the VSM-5, the operator can get the "whole picture" at once.

The instrument can be used as a field-strength meter, too, for orienting antennas, measuring their gain, and similar tricks. The height of the pips on the screen is directly proportional to the signal strength. In CATV systems which change channel frequencies, it can be used with an external standard to verify that the new carrier is exactly on-frequency.

With a special "slow-sweep" generator, the whole CATV system can be tested for flat response. This can be done with the system in full operation; the subscribers don't even know it's being done! The sweep-generator is fed in at the head-end, and the VSM-5 is connected to a tap at the end of the line. The slow-sweep generator generates a continuous-wave that is swept at such a speed that it passes through active channels without causing any disturbance to the picture. The VSM-5 is set to the same sweep frequency and the resulting trace can be photographed to verify flat response of the entire system.

By adjusting the DISPERSION control, each channel can be checked. The sound and video carriers will show up as sharp pips, and the color carrier as a constantly varying smear. Any sign of intermodulation distortion in the system shows up instantly as a pip where there shouldn't be one. At a very wide setting of the DISPERSION control, the harmonics of the horizontal sweep show up.

The harmonics are spaced 15.75 kHz apart and any IM shows up between these.

Hum levels in the system can be checked, and signal-to-noise readings taken. If any interfering signals are spotted, the instrument can be set to a lower resolution so that the exact frequency of the interfering signal can be found. The resolution can be set to 200 kHz, 10 kHz or 0.5 kHz (500 Hz) for this. For verification, markers can be switched in at 1, 10 or 50 MHz. These generate a set of zero-beats or birdies for this test. By counting the number of beats, say at 1.0 MHz apart, the signals can be identified.

Beside the variable VHF sweep, three preset bands may be used. These can be tuned to any frequency in the range for tests where the same signal must be checked. For example, we used the markers to check out a set of CB traps by setting up a 27-MHz signal at the left side of the screen, its 2nd harmonic (54 MHz) in the middle, and the 3rd harmonic on the right. By hooking the traps in series with the input and tuning them, their effect could be instantly seen. The same method could be used for setting TV interference traps in a CB (or any) transmitter. All you need is a signal generator that will give you harmonics. I found out, by the way, that my RF signal generator wasn't all that "pure": with the output cranked wide open it developed a very perceptible 2nd harmonic! For checking CB transmitters, all you need is an RF pickoff that will give you about 1.0 watt into the VSM-5 input. The instrument has pushbutton attenuators on the front panel that are capable of providing a total of 62 dBmV in 7 steps. There are two 20-dBmV

attenuators, then 1,2,3,6 and 10 dBmV so that you can get whatever attenuation is needed. The actual signal level is then read from the screen and the in-circuit attenuators added to this.

The VSM-5 is powered by an internal 12-volt battery that is rechargeable or from a 117-230-VAC line. It is fully portable and may be used "portable" in the field for up to three hours of continuous operation. This makes it ideal for use as a mobile unit for detecting and measuring cable leakage, antenna testing, gain comparisons and you-name-it.

This instrument will do a lot more things; its usefulness is limited only by the ingenuity of the operator. (This almost got me, at first, but by diligent reading of the instruction manual, I finally made it do everything I wanted it to!) The actual operation is quite simple once you learn how, which really doesn't take all that long. The suggested retail price of the VSM-5 is \$3950. **R-E**

Thanks to you
it works...
FOR ALL OF US



advertising contributed
for the public good



Treat yourself to a new direct reading DVM today.



DVM35

POCKET PORTABLE
ANALOG REPLACEMENT

3-digit, 1% DCV,
Battery or AC

Only \$134



DVM36

LAB ACCURATE
POCKET PORTABLE

3½ digit, .5% DCV,
Battery or AC

Only \$158

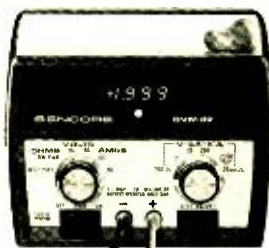

DVM32

BENCH & FIELD MASTER

3½ digit, .5% DCV,
Battery or AC

Only \$198



DVM38

"PRIME" STANDARD
AT YOUR FINGERTIPS

3½ digit, 1% DCV,
Auto-Ranging

Only \$348

A COMPLETE LINE OF DVMs TO FILL YOUR EVERY NEED OR WANT.

You can be sure more times in more circuits, under more adverse conditions, with greater versatility, accuracy, and meter protection than any other digital multimeters on the market today; and for less money too. 10 Day Free Trial: Try any of these famous DVMs for 10 days. If the DVMs in use don't prove exactly what we say, return them to your Sencore FLPD Distributor.

Want more information? We would like to tell you all about the Sencore DVMs by sending you a 24-page Sencore News, a six-page brochure, and the name of your nearest Sencore Distributor today... simply write or circle reader's service number.

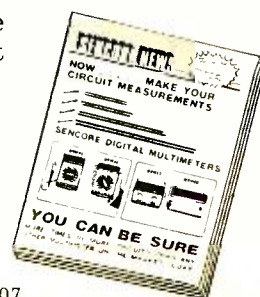

3200 Sencore Drive, Sioux Falls, SD 57107

CIRCLE 76 ON FREE INFORMATION CARD

Unique full-function 8-digit wrist calculator... available only as a kit.

A wrist calculator is the ultimate in common-sense portable calculating power. Even a pocket calculator goes where your pocket goes—take your jacket off, and you're lost!

But a wrist calculator is only worth having if it offers a genuinely comprehensive range of functions, with a full-size 8-digit display.

This one does. What's more, because it is a kit, supplied *direct* from the manufacturer, it costs only a very reasonable \$19.95. And for that, you get not only a high-calibre calculator, but the fascination of building it yourself.

How to make 10 keys do the work of 27

The Sinclair Instrument wrist calculator offers the full range of arithmetic functions. It uses normal algebraic logic ('enter it as you write it'). But in addition, it offers a % key; plus the convenience functions \sqrt{x} , $1/x$, x^2 ; plus a full 5-function memory.

All this, from just 10 keys! The secret? An ingenious, simple three-position switch. It works like this.

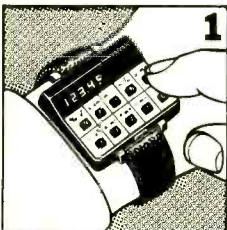

1. The switch in its normal, central position. With the switch centered, numbers—which make up the vast majority of key-strokes—are tapped in the normal way.

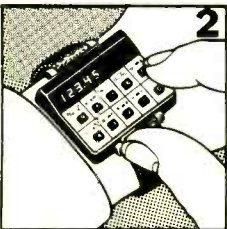

2. Hold the switch to the left to use the functions to the left above the keys...

3. ...and hold it to the right to use the functions to the right above the keys.

The display uses 8 full-size red LED digits, and the calculator runs on readily-available hearing-aid batteries to give weeks of normal use.

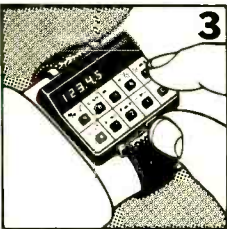

Assembling the Sinclair Instrument wrist calculator

The wrist calculator kit comes to you complete and ready for assembly. All you need is a reasonable degree of skill with a fine-point soldering iron.

It takes about three hours to assemble. If anything goes wrong, Sinclair Instrument will replace any damaged components *free*: we want you to enjoy assembling the kit, and to end up with a valuable and useful calculator.

Actual Size

Contents

Case and display window.
Strap.
Printed circuit board.
Switches.
Special direct-drive chip (no interface chip needed)
Display.
Batteries.

Everything is packaged in a neat plastic box, and accompanied by full instructions.

The only thing you need is a fine-point soldering iron.

All components are fully guaranteed, and any which are damaged during assembly will be replaced free.

The wrist-calculator kit is available only direct from Sinclair Instrument. Take advantage of this 10 day money-back offer.

Send the coupon today.

**KIT ONLY
\$19.95**

**Sinclair Instruments Inc.
6 Commercial Street
Hicksville, N.Y. 11801**

To: Sinclair Instruments Inc.
6 Commercial Street
Hicksville, NY 11801

RE-2

Please send me

_____ Sinclair wrist calculator kit(s) at \$19.95\$ _____

Sales tax (NY residents) _____

Shipping & handling (\$2.50 per unit) _____

Enclosed is check/MO (payable to Sinclair Instruments Inc.) TOTAL \$ _____

Name _____

Address _____

City _____

State _____ Zip _____

I understand that you will refund the purchase price of the kit in full if I return it in saleable condition within 10 days of receipt.

Measure $f\tau^*$ and a full range of semiconductor parameters for under \$300!

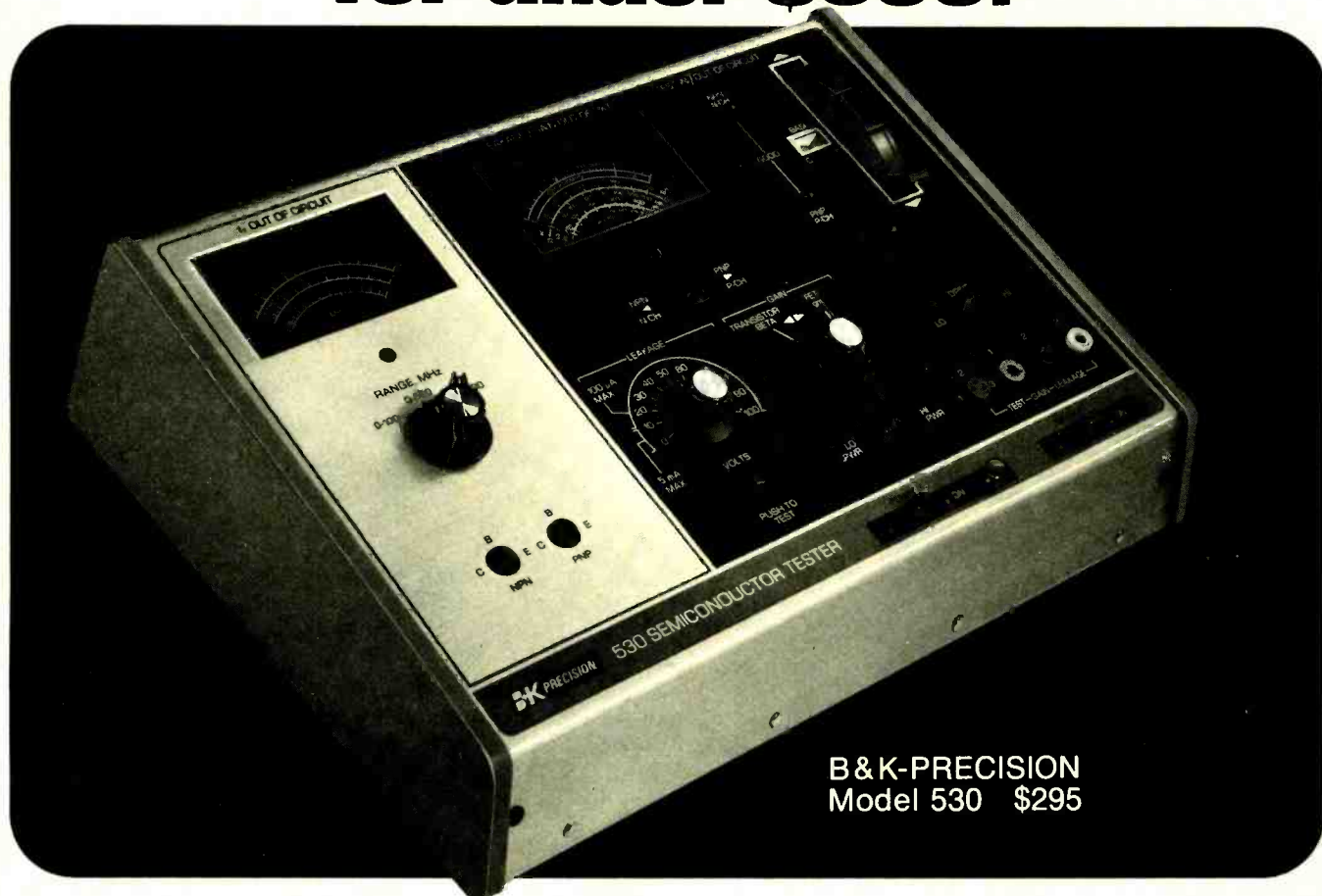

with the B & K-PRECISION Model 530

New from B & K-PRECISION, the Model 530 semiconductor tester can actually perform more tests, on more devices, than any other competitively priced semiconductor tester. In the engineering lab, the 530 provides a full range of accurate data including an exclusive bipolar transistor gain-bandwidth product measurement capability to 1500 MHz.

In-circuit tests include:

- Positive good/bad tests for bipolar transistors, FET's, diodes, and SCR's
- Polarity identification of all semiconductor devices, including identification of N or P channel FET's
- Identification of all leads of bipolar transistors
- Gate lead identification of FET's
- Identification of all leads of SCR's

Out-of-circuit tests include:

- Transistor gain-bandwidth product($f\tau$) up to 1500 MHz
- Transistor beta using two collector current ranges
- G_m of FET's—including high-power devices
- Nondestructive testing of transistor, SCR and diode breakdown voltages up to 100 volts
- Reverse leakage from $0.5 \mu A$ to 5mA for transistors, SCR's and diodes
- I_{DSS} and gate leakage of FET's
- Identification of device as bipolar transistor, FET or SCR
- Plus all in-circuit tests and many more parameters

The 530 is not only one of the most complete semiconductor testers available, it's one of the easiest and fastest to use. No charts, tables or calculations are required for basic operation, nor is additional equipment required. The 530 is a direct reading stand-alone instrument. Even unskilled assembly line workers can perform quality control tests with minimal training. Both visual and aural test indications are provided.

The B & K-PRECISION Model 530 is priced at only \$295. For additional information or for immediate delivery see your nearest B & K-PRECISION distributor.

*Gain-bandwidth product or unity-gain frequency.

B&K PRECISION
PRODUCTS OF DYNASCAN

6460 W. Cortland Avenue, Chicago, IL 60635 312/889-9087

Radio-Electronics
40-CHANNEL
CB SPECTACULAR
SPECIAL 16-PAGE SECTION



IN THIS SECTION

-
- | | |
|-----------|-----------------------------------|
| 40 | Equipment Roundup |
| 45 | Antennas For 40-Channels |
| 47 | Phase Lock Loop |
| 50 | New FCC Rules |
| 51 | Manufacturer's Listing |
| 54 | Installing Coax Connectors |

40-Channel

The approval of 40-channel monium among manufacturers to abate. Some new type-accepted shelves and others on the way.

JANUARY 1, 1977, WILL PROBABLY BE RATED AS A GREAT DAY FOR the shipping industry, thanks to the Citizens Band radio industry. That was the word at press-time in mid-December as CB producers lined up type-accepted 40-channel equipment for shipment to retail stores for Jan. 3 selling.

Some companies said they had trucks standing by waiting to head for local or area warehouses and shipping points as soon as the New Year was born. Others said they would wait a few hours and use airliners to convey their new products to dealers anxious to have them for sale the first Monday of 1977.

While the Federal Communications Commission has done a yeoman job of processing hundreds of product submissions, there are more to complete. However, the industry has enough approved product to convince early 40-channel CB shoppers that the new medium is actually here, and there are plenty of

goodies from which to make a selection. The feeling is that by March 1 all current prototype submissions will have been processed and the initial product lineup will be complete.

In brief asides to our new product information gathering, we learned that most manufacturers are not expecting consumers to "break down doors to get the new sets," as one put it. Some are expecting a new wave of confusion in the marketplace as potential purchasers evaluate the new offerings at their initial high prices against existing 23-channel product at deeply discounted prices. Said one supplier: "That price differential is really going to tell us what the bottom line actually is." Manufacturers who have been looking forward to January 1, 1977, have been doing so with somewhat lower sales expectations than, say, when they were anticipating January 1, 1976.

Come January the industry as well as the consumer will get

Alpine

Type accepted: *BR640*. No details.

Audiovox

Several units at FCC of a proposed 10-model line for 1977. Marketing expected to begin in March. Line will consist of six in-dash models, some with FM, and four under-dash units. (150 Marcus Blvd., Hauppauge, NY, 11787)

Automatic Radio

Two under-dash models at FCC, prototypes of which had earlier been type-accepted. Expected to be ready for sale on Jan. 3. The sets are: *Model CBL2270*, list priced at \$181.95, with built-in slide-in/out theft-proof bracket, RF gain, Delta tune; and *CBH2265*, list priced at \$202.50, with theft-proof bracket, RF gain, LED readout. (2 Main Street, Melrose, MA 02176)

B & B

At FCC: Five mobiles, one base unit. Prices expected to be "approximately the same price as equivalent 23-channel models when originally introduced." Two models are expected to be ready for January shipment. (185 Park St., Troy, MI 48064)

B & B's Alaron B-4075

Benjamin

Type accepted: *Model 200*. No details.

Bohsei

At FCC: Two mobiles. Expected to be available in March. (7037 Hayvenhurst Ave., Van Nuys, CA 91406)

Boman

Type accepted: *Model CBR-9950*, not priced, in-dash AM/FM/FM stereo/CB with LED readout, T/R mode indicator light, S/RF meter, ANL, fader control for four speakers.

At FCC: Nine models, consisting of two in-dash, four under-dash, one base station, one modular hideaway (trunk, firewall installation), and one hideaway for attachment to stereo player.

Expects to ship *CBR-9950* Jan. 1. (9300 Hall Road, Downey, CA 90241)

Browning

Five models at FCC—three AM under-dash, one SSB AM under-dash, one single sideband AM base station. No pricing set.

Company is confident all five will be type accepted, with some product ready for shipment to dealers for Jan. 3 sell-



Boman CBH-995 base unit.

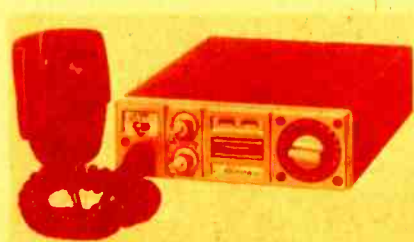

ing, more ready within 10 days. (1269 Union Ave., Laconia, NH 03246)

Channel Master

Type accepted: Under-dash *Model CB-6835*, featuring PLL, LED readout, Delta tune, ANL, noise blanker. Price not set.

At FCC: One under-dash model. Expects also to submit a base station to

Roundup

CB unleashed a pandemic that is just starting. Models are on dealer's shelves. Here's what to look for

FRED PETRAS

a final fix on CB as regards the position of 23-channel versus 40-channel. Several suppliers—some with big, some with small 23-channel inventories—predicted that as the consumer weighs the merits of both types, he will be inclined to lean toward 23's in terms of their initial wide price differential. This, say the producers, may cause some dealers to jack up the prices of 23-channel units in their stocks closer to their earlier prices—but not all the way. For example, units that once sold for \$140, later discounted to \$110, then to \$90, and finally on retail shelves at \$70, may be hiked back up to, say, \$100 or \$110. This will preserve a substantial price differential for the cost-conscious consumer. However, we expect to see the supply of 23-channel equipment dry up by the middle of the year. So if you plan to buy 23, you best buy soon.

Other industry members are predicting that the gap will lessen as 40-channel prices move down to "realistic" levels

that will be determined in part by consumer acceptance of, or resistance to, the new products.

While we have scoured the industry to come up with a comprehensive roundup of 40-channel product available for January, 1977, selling, that roundup understandably is not complete in the light of: Early press deadlines common to magazine publishing; The unfinished processing of submitted prototype products by the FCC; Incomplete information on the part of CB manufacturers. We beg your indulgence under these circumstances. We hope to add to the information that follows with a second listing in our next issue.

NOTE: Prices indicated are those given when companies were contacted. Some are approximate, and are so indicated. Some prices may change, in line with production/materials cost vagaries.

FCC for late winter/early spring marketing. (Ellenville, NY 12428)

Clarion

Awaiting approval at FCC are: *Model 367*, \$329, in-dash AM/FM/FM stereo/CB; *Model 621*, \$359, same as 367 plus 8-track player; *Model 672*, \$379, same as 367 but with cassette mechanism; *Model RCJ-003*, \$199, modular system with separate integrated head containing mike and controls, with electronics mountable on firewall, under dash, under seat, or in trunk.

Expected to be in production in January for marketing the latter part of February. (5500 Rosecrans Ave., Lawndale, CA 90260)

Cobra

At FCC: Nine models, most variations on one basic chassis, consisting of six AM mobiles, two SSB mobiles, one base station. Expects to have some units for shipment Jan. 1. Complete 1977 line will consist of 12 models. (6460 W. Cortland Ave., Chicago, IL 60635)

Cobra 21XLR

meter, PA. Expected to be available at retail mid-January.

At FCC: *450*, \$230, under-dash, same features as 290 plus mike gain control, SWR meter; *480*, \$320, under-dash, AM/SSB, with same basic features as 450; *800*, \$300, AM base station, LED readout, walnut cabinet, SWR calibration, Delta tune, ANL, noise blanker. (5725 N. Central Ave., Chicago, IL 60646)

Commando

Type accepted: *CC-4040*, under-dash AM radio, LED readout, PLL. No price set. *CC4086*, no details.

At FCC: *CC-4050*, under-dash mini model, LED readout, PLL; *CC-4055*,

Units at FCC expected to be approved in time for marketing Jan. 1. (P.O. Box 11071, Chattanooga, TN.)

Craig

At FCC: *Model L-101*, under-dash, approximate price \$170. Features include Day/Night filament channel readout under all illumination conditions, reversible slide-out bracket, switchable ANL, PA, squelch, large S/R/F meter, proprietary Craig mike/control unit.

Model L-131, under-dash SSB, with full complement of SSB controls, noise blanker, Day/Night channel indicator. Approximate price, \$360.

Model L-231, SSB base station, approximate price \$500. Features include digital clock alarm timer circuitry, dual antenna input.

Model L-600, under-dash, approximately \$280. Features include 2-speed up/down channel selector on Craig mike and radio itself, provision for foot-switch channel selection, Day/Night channel indicator, hideaway mike bracket. (921 West Artesia Blvd., Compton, CA 90220)

Fanon/Courier

Fanon division. At FCC: Eight models, consisting of one AM base station, one AM SSB under-dash unit, five



Colt

Type accepted: *Model 290*, \$200, under-dash, with LED readout, ANL, noise blanker, Delta tune, RF gain, S-

under-dash full-feature unit with Delta tune, PA, LED readout, PLL; *CC-5010*, in-dash AM/FM/CB combo with LED readout and PLL.

under-dash AM units, and one in-dash combination—AM/FM/FM stereo/CB with Channel 9 priority switch and LED readout/selector built into the mike. One of the five under-dash units also has the latter feature.

Six of the above expected to be ready for sale on Jan. 1. (Subsequently type accepted: *Fanfare 100F*, no details.)

Courier division: Type accepted: *Rebel 40*, under-dash, priced at \$100.

At FCC: Eleven models, all expected to be type accepted for January 1 selling. (990 South Fair Oaks Ave., Pasadena, CA 91105)

Xtal

At FCC: Six models in the XTAL brand consisting of two under-dash, four modulars for trunk or firewall installation. No price information. (Far Eastern Research Laboratories, 8749 Shirley Ave., Northridge, CA 91324)

Fieldmaster

At FCC: *Model TR-40*, \$260, under-dash, with noise blanker, ANL, PA, RIT tuning, and separate LED readout unit for above-dash mounting. *Micro-Mini-40*, \$240, under-dash compact, LED readout, ANL, noise blanker, PA.

Both expected to be available at retail on Jan. 3. (21212 Vanowen St., Canoga Park, CA 91303)

Arthur Fulmer

At FCC: *Model 15-4035*, under-dash AM/FM/FM stereo/CB with automatic warning light, and full lineup of features including ANL and noise blanker; *Model 16-8400*, in-dash AM/FM/FM stereo/CB with LED readout, monitor override, overload circuitry. Former expected to be available "almost immediately" in January, the latter by Feb. 1. No prices set.

Expected for spring sale, a low-priced unit, *Model 15-4030*, no details. (P.O. Box 117, 260 Monroe, Memphis, TN 38103)

GC

At FCC: *Model 9200*, under-dash, with full complement of features, including PA and noise blanker.

Planning to submit several more for type acceptance. (4000 South Wyman St., Rockford, IL 61101)

Gemtronics

Six models at FCC—five under-dash with "standard" features, plus one base station. Expected to be approved in time for January marketing. (356 South Blvd., Lake City, SC 29560)

General Electric

Type accepted (all under-dash units): *Model 3-5801*, \$135, lighted S/RF meter, quick release mounting system, switchable ANL; *Model 3-5811*, \$160, large meter, PA, switchable ANL; *Model*

3-5819, \$220, with 3-way lighted meter, LED readout, antenna warning light, switchable noise blanker and ANL; *Model 3-5821*, \$240, with channel priority feature, S/RF meter, PA, LED readout. *Model 3-5812*, \$175, with S/RF meter, switchable noise blanker and ANL. *Model 3-5825*, \$330, SSB, with AWI light, S/RF meter, LED readout.

At FCC: *Model 3-5871*, \$250, AC/DC base station with LED readout, S/RF meter, switchable ANL.

Units expected to be ready for delivery to dealers on Jan. 1. (Audio Electronics Products Dept., Syracuse, NY 13212)

Hallicrafters (Breaker)

At FCC: Five "Hallicrafters" brand under-dash units, as follows: *Model HCM-275*, approximately \$200, "high specs"; *HCM-272*, \$230, and *HCM-271*, \$210, both with LED readout; *HCM-270*, \$190; *HCM-261*, \$170.

Expected to be type accepted in time for early January sale. (1101 Great Southwest Parkway, Arlington, TX 76011)

Hanabashiya

No products at FCC. Earliest possible 40-channel products in March. (39 West 28th Street, New York, NY 10001)

Handic

Sent 15 models to FCC too late for

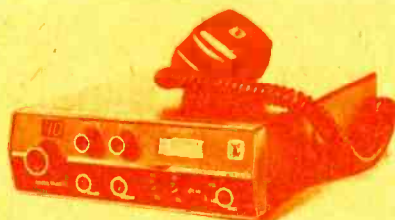

Johnson Viking 4740

January selling. They consist of four mobile under-dash units, 1 in-dash AM/FM/FM stereo/CB, 2 base stations, 1 mobile SSB and 1 base SSB, 4 hand-held transceivers, 2 limited-channel (3 and 6) mobiles using crystals. Handic is projecting a starting price of \$140, with most full-feature models in the \$200 to \$250 range. (14560 N.W. 60th Ave., Miami Lakes, FL 33014)

Hy-Gain

Type accepted: *Model 2701*, \$139.95, under-dash model with ANL, volume/squelch control, remote speaker jack, illuminated channel selector, TVI filter; *Model 2703*, no details. Both expected to be available Jan. 1

At FCC: "About 20" models, consisting of in-dash, under-dash, remote-control and SSB sets, including one AM/FM/FM stereo/CB combo with cartridge playback facilities. (8601 N.E. Highway 6, Lincoln, NE 68505)

I. A. Sales

At FCC: *Models TRX-400* and *TRX-500*, both under-dash, both with full complement of features. Expected to be retailed in January. (766 Lakefield Road, Westlake Village, CA 91361)

Inland Dynatronics

No information available. (10 Horizon Blvd., South Hackensack, NJ)

J.I.L.

At FCC: *Model 860*, suggested list price \$400, in-dash AM/FM/FM stereo/8-track cartridge/CB; *Model 615*, \$420, same as *860* but with cassette mechanism instead of cartridge; *Model 853-401*, \$390, in-dash, AM/FM/8-track/CB; *Model 853-201*, \$690, 120-channel SSB in-dash with AM/FM/8-track cartridge facilities. *Model 706*, \$375, in-dash AM/FM/FM stereo/CB with push-button tuning. SSB version of *706*, \$670. (737 West Artesia, Compton, CA 90220)

Ray Jefferson

At FCC: *CB-740*, \$150, under-dash; *CB-845*, \$200, deluxe under-dash with LED readout, ANL, Delta tune; *CB-7120*, \$300, SSB under-dash; *CB-702*, \$280 (approximate), LED readout; *CB-712*, \$230 (approximate), marine unit.

Expected to be ready for January 1 selling. (Main and Cotton Streets, Philadelphia, PA 19127)

E. F. Johnson

At FCC: Five under-dash units under the *Messenger* brand name, all with LED readouts, as follows: *4120*, suggested list \$110; *4140*, \$180; *4145*, \$180; *4170*, \$250; *4175*, \$250. *Messenger Model 4230*, \$250, AM base station. *Viking Model 4740*, under-dash SSB priced at \$360. (299 10th Ave., SW, Waseca, MN 56093)

Kraco

Type accepted: *Model KCB-4003*, under-dash leader model, no price set; *Model KCB-4030*, \$220, under-dash with PLL, S/RF meter, squelch, ANL, noise blanker, Delta tune; *Model KCB-4020*, \$180, same features as *4030* but no noise blanker; *KCB-4088*, no information.

At FCC: *Model KCB-4010*, \$140,



Hy-Gain 2705

under-dash mini model, PLL, squelch, ANL, S/RF meter. (505 East Euclid Ave., Compton, CA 90224)

Kris

Has three under-dash CB radios at FCC. They are: *XL-40*, \$160, with ANL, PA, RF meter; *XL-45*, \$210, with ANL and noise blanker, PA, LED readout; *XL-50*, \$260, deluxe full-feature unit with 3 meters (RF, signal strength, modulation) talk-back feature, ANL and noise blanker, meter dimmer control.

Kris expects to have the units type accepted in time for "early January" sale. The company also plans to submit "at least two other models" for eventual marketing later in 1977. (Pioneer Road, Cedarsburg, WI 53012)

Krypton

One under-dash model at FCC. Sending one under-dash and one-in dash to FCC in January. Markets under *BETA* brand name. (18 Mileed Way, Avenel, NJ 07001)

Lafayette

Type accepted: *HB-940*, \$200, LED readout, SWR calibration control, RF gain, squelch, Delta tune, noise blanker, ANL, S-RF meter, PLL; *HB-740*, \$160, PLL, Delta tune, ANL, noise blanker; *HB-640*, \$120, with PLL, S/RF meter, transmission indicator, squelch, PA.

At FCC: base station and two SSBs.

Type accepted models to be available in all Lafayette company-owned and franchised stores Jan. 3. (111 Jericho Turnpike, Syosset, NY 11791)

Lake

No information available. (1948 E. Lehigh Ave., Glenview, IL 60025)

Maxon

Type accepted: *Maxon 40*. No details.

Meishoh

Type accepted: *ME-402*. No details.

Meriton

Type accepted: *RS-5111*. No details. (35 Oxford Drive, Moonachie, NJ 07074)

Midland

Type accepted: Four under-dash models all with ANL and Delta tuning, squelch, and illuminated rotary dial tuning, among key features. They are: *Models 77-857; 77-882; 77-888; 77-883*. No price or shipping date information available at press time. Also type accepted, *Model 63-240*, and *77-853*, no details. (P. O. Box 1903, Kansas City, MO. 64171)

Motorola

No information available. (1499 E.

Algonquin Road, Schaumburg, IL 60196)

Nuvox

No 40-channel products planned at this time. Will enter the market when pricing "becomes practical and reasonable" as opposed to the current heavy discounting prevalent in 23-channel CB, said a spokesman. (150 Fifth Avenue, New York, NY 10011)

Pace

Type accepted: *Model 8041*, \$200, under-dash unit featuring Delta tune, PLL, antenna warning light.

At FCC: Eighteen models consisting of 12 mobiles, three base stations, two in-dash AM/FM/CB combos, one scanner. Combos include cartridge or cassette facilities.

Pace expects to ship between 15 and 17 models starting Jan. 1. (24049 S. Frampton Ave., Harbor City, CA 90710)

Palomar

Six units at FCC. Expects three imported models to be approved in time for February selling, three all-American-made in time for sale by end of first quarter.

Import units for possible sale in February are: *Palomar Model 41*, list priced at about \$185. Features include LED readout, switchable ANL, squelch, PA; *Model 4100*, approximately \$219, whose features include those of *41* plus RF and microphone controls, snapper styling; *Model 49*, approximate price \$249, same features as above two units plus noise blanker. All three are 4-watt, under-dash units.

Three all-American-made models consist of one tube-type base station, one mobile AM under-dash, and one deluxe SSB AM base unit. (665 Opper St., Escondido, CA. 92925)

Panasonic

Consumer Electronics Group: Four under-dash units at FCC, as follows: *RJ-3250*, \$200, with quick-release mounting bracket, Channel 9 priority switch, LED readout; *RJ-3450*, \$230, 2-piece modular system for under-seat, trunk, firewall installation, with built-in scanner system, remote control mike; *RJ-3150*, \$170, and *RJ-3050*, \$130, both with LED readout.

Auto Products Dept: Type accepted: *Model CR-B4747*, in-dash AM/FM/FM stereo/CB radio with push-button tuning; *Model CR-B 4700*, mini in-dash AM/FM/FM stereo/CB radio with manual tuning. No prices set.

Three models at FCC. No details.

Type accepted models will "absolutely be ready for January 1 shipping" (One Panasonic Way, Secaucus, NJ 07094)

Pearce-Simpson

Type accepted: *Tiger 40*, no price set, under-dash, Delta tune, PA, ANL, noise blanker, S/RF meter, tone, squelch; *Super Cougar 40*, under-dash unit whose features and styling are expected to be revised before marketing, along with a name change.

Submitted "at least 10 pieces to the FCC," in line with plans to have an eight to 10-unit 40-channel line in 1977,



Pace 8155 base unit.

made up of mobile and base units, and SSB's. (4701 NW 77th Ave., Miami, FL 33152)

J. C. Penney

Type accepted: *Model 6205*. No details.

Pioneer

Type accepted: *GT-6600*, no price set, in-dash AM/FM/CB with ANL, squelch, S meter, five pre-set tuning buttons. Expected to be on sale Jan. 1.

At FCC: *Model 1100*, no price, in-dash, AM/FM/CB with ANL, squelch, S meter, manual tuning. (1555 E. Del Amo Blvd., Carson, CA 90746)

more 40-channel CB equipment on next page.



Panasonic FJ-3050



Panasonic RJ-3150

President

Type accepted: *Zachary T.*, \$250, AM base station with ANL, PA, RF gain, LED readout, S/RF meter.

At FCC: Six models—also named after presidents of the United States—expected to be type accepted in time for January 1 retailing. They are: *Model John Q.*, suggested list price, \$170, under-dash AM mobile with ANL, PA, LED readout, S/RF meter; *Honest Abe*, \$200, under-dash AM, PA, ANL, Delta tune, S/RF meter, LED readout; *Teddy R.*, \$230, under-dash AM, PA, noise blanker, SWR calibration, Delta tune, LED readout, S/RF meter, PA; *Dwight D.*, \$330, AM base station, noise blanker, PA, RF gain, tone, SWR calibration, clock, alarm control, Delta tune PA, on-air light, LED readout, with separate speaker; *Grant*, \$340, SSB AM under-dash, PA, noise blanker, LED readout, S/RF meter, mike gain; *Washington*, \$430, SSB AM base station, PA, noise blanker, mike gain, RF gain, clarifier, PA, LED readout, S/RF meter. (16691 Hale Ave., Irvine, CA 92714)



President Washington



President Dwight D.

At FCC: Two mobiles and one base station. The firm expects these to be accepted by Jan. 1, but their actual retailing time will be determined by Shakespeare's Japanese supplier. (P. O. Box 246, Columbia, SC 29202)

Sharp

Type accepted: *CB-2260*, approximately \$140, under-dash, Delta tune, lighted drum channel indicator, flashing Channel 9 indicator, ANL, PA, squelch; *CB-2460*, approximately \$150, same as 2260 but with LED readout.

Delivery expected first week of January. (10 Keystone Place, Paramus, NJ 07652)

Siltronix

Late in submitting prototypes to the FCC, this company will not have 40-channel CB's until late February. Awaiting FCC action are three under-dash units, all featuring PLL and LED readouts. (330 Via El Centro Ave., Oceanside, CA 92054)

Sparkomatic

At FCC: Five mobile under-dash and two base stations. Three of the mobiles have touch-bar channel switching. One has "memory" control for automatic tuning of one channel. (Milford, PA 18337)

Standard

Expects to have unit now at FCC approved for sale in January. It is a 40-channel version of the firm's *Horizon 29*, to be called *Horizon 29A*, a mobile model featuring ANL, AN blanking, Delta tune, and squelch, among features. It will carry the same list price as the 23-channel model, \$229.95. (P. O. Box 92151, Los Angeles, CA 90009)

Surveyor

At FCC: One AM base station; one SSB base; one in-dash AM/FM/CB combo with LED readout; three under-dash (one with LED readout). (7 Electronics Court, Madison Heights, MI 48071)

Teaberry

Type accepted: *Model 4002*, AM base, dial selector; *4006*, AM mobile, LED readout; *4001*, SSB mobile, dial selector. All three with PLL.

At FCC: One SSB base unit, one SSB mobile; one base, two AM mobiles.

Pricing to be determined at end of December. At least five models expected to be ready for shipment Jan. 1. (6330 Castleplace Drive, Indianapolis, IN 46250)

Tram/Diamond

Five units at FCC: *Model D-42*, with ANL, LED readout, PLL; *D-12*, with PLL (both units under-dash); one SSB

continued on page 50

Radio Shack

Type accepted: *TRC-455*, AM base station, PLL, LED readout; *TRC-466*, low-priced "very small" under-dash AM with illuminated channel switching; *Mini-40*, compact under-dash AM with illuminated channel switching.

Company expects to have 14-unit line of 40-channel CB's for 1977 selling. (2617 West 7th St., Fort Worth, TX 76107)

RCA

Type accepted: *Model 14T304*, AM mobile unit with LED readout; *14T270*, AM mobile unit, 40-detent channel switch. Both models with ANL. No prices established.

At FCC: Eight models, as follows: one SSB, one base station; five mobiles, one AM/FM in-dash combo. These are expected to be accepted in time for sale in January. (Cherry Hill Offices, Bldg. 206-2 Camden, NJ 08101)

Regency

Type accepted: *Models CR-430, 485, 486*, all foreign-made under-dash units with LED readouts, expected—"Hopefully"—to be available at retail Jan. 3.

At FCC: *Model CB-501*, American-made under-dash unit, first of what will be a completely American-made line.

Price range of the above four models is from \$159.95 to \$219.95. (7707 Records St., Indianapolis, IN 46226)

Robyn

Eleven models at FCC, with first seven of those in the following list expected to be approved in time for Jan. 1 marketing, the rest shortly thereafter. All units listed feature PLL. All except

T-240-D are under-dash radios. *Model WV-110*, suggested list price \$150. *WV-110P*, same as *110* with antenna and coaxial speaker, \$170. *LB-120*, \$160. (Above three units feature back-lighted rotary channel indicator.) *DG-130D*, \$180, with digital readout. *SX-401*, \$190, with rotary back-lit channel indicator. *SX-402D*, \$240, with digital readout. *007-140*, \$200, with antenna, coaxial speaker, *TR-210D*, \$200. *GT-410D*, \$260, with digital readout, turn-on/turn-off switch that automatically returns to Channel 9, scanner switch. *GT-440D*, \$380, SSB with digital readout. *T-240D*, \$300, mobile or base station radio using vacuum tubes, featuring digital readout, PLL. (P. O. Box 478, 10901 Northland Drive, Rockford, MI., 49341)

Royce

At FCC: *Models 1-673; 1-675; 1-678; 1-680; 1-682*. No details. (1746 Levee Road, North Kansas City, MO 64116)

SBE

Ten under-dash radios at FCC. Most feature LED readouts, all use PLL circuitry.

It is expected that the units will be type accepted in time for Jan. 3 retail sale. (220 Airport Blvd., Watsonville, CA 95076)

Sears Roebuck

Type accepted: *Models 28 62674, CM 2378SA, CM 6000LB, TA 4501, 28 62676, CM 6000LA, CM 6100S*. No details available.

Shakespeare

Type accepted: *Model GBS-240*, no details.

Antennas for 40-Channels

The addition of 17 new channels requires increased performance from mobile antennas. An understanding of the design and mounting considerations is necessary to select an antenna to meet the new requirements

IT SHOULD COME AS NO SURPRISE THAT CB radio has entered an exciting new stage of growth. The FCC announcement of expanded Class-D service with the addition of seventeen channels was encouraging since it supported the largest of radio services. Unfortunately, the announcement also generated considerable confusion about the status of existing CB products. It also raised the question of just what new products would be made available to fill the needs of the 40-channel market. Now that the dust has settled, what Antenna Specialists has done to meet the need for forty-channel CB antennas should reduce some of the confusion about antenna products and the expansion.

First, it is very important to know that an antenna is not just a piece of cable, a coil, and a steel tip rod. There are many factors that enter into antenna design and affect antenna performance. Since base-station antennas are already "broad band" and will cover the proposed additional channels, they will not be discussed in this article. Mobile antennas provide a whole different set of conditions; however, and those conditions should be understood if proper antennas are to be selected for

RICHARD BITNER

*The Antenna Specialists Co.

each application. Some basics of antenna design and history will help to clarify the problem.

Basic antenna design

As mentioned above, an antenna is more than a length of cable, a coil, and a rod. Stated in its most simple terms, an antenna is a device that is capable of sending and receiving radio-frequency energy.

That's simple enough, but simple things are often misleading. For example, each antenna must be constructed to operate over a specific range of frequencies. In addition, each antenna must be tuned to operate with a maximum efficiency and it must function equally well both transmitting and receiving. Under most conditions an antenna works best as a half-wavelength radiator.

On CB frequencies, 27-MHz. one-half wavelength is about 18 feet long. A quarter-wavelength radiator and a quarter-wavelength mirror image or ground plane make up the 18-foot

system. In the early days of CB, the most common kind of antenna was the 108-inch whip and spring combination. Whip and spring were the active or radiating half of the system and the vehicle body acted as its "mirror image" or ground plane. In effect, this formed the dipole antenna. The long whip system was broad band and offered little problem in terms of matching the antenna to the transmitter.

The quarter-wavelength whip and spring combination did have some problems in terms of aesthetics. In addition, the quarter-wave whip & spring combination has some mounting difficulties since most people don't like a 9-foot whip on top of their car. The most common place to mount the antenna, bumper or deck, played games with the antenna's radiation pattern. The quarter-wave whip can also be a problem where areas of low clearance exist.

To meet some of the above shortcomings, a loaded antenna was developed. In this way we make antennas mechanically shorter without significantly changing electrical efficiency. The loading coil changes the antenna's voltage and current components and narrows the bandwidth of operation.

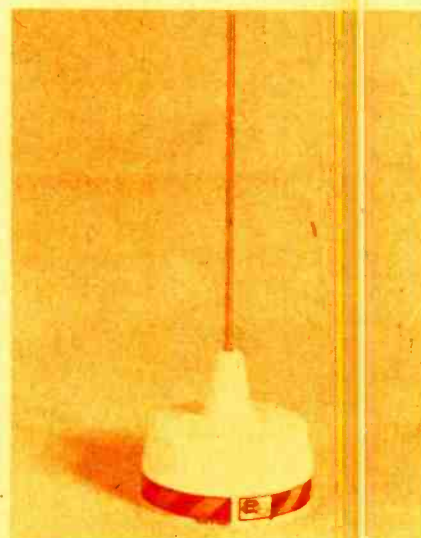
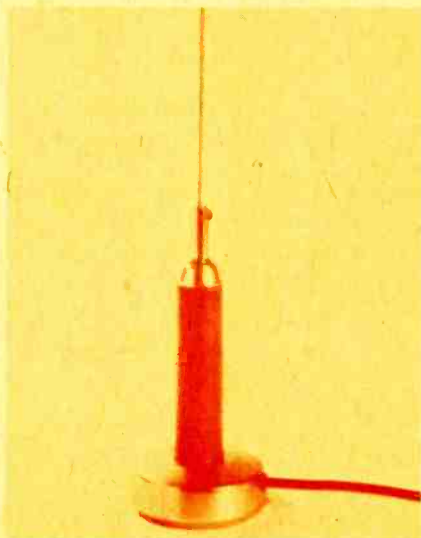

THREE BASE-LOADED WHIPS from Antenna Specialists. The models MS178 (left), M-276 (middle) and M-440 (right).

Operation at or near the resonant frequency is excellent. Using a loading coil permits an antenna of almost any length to be developed *but*, the shorter the length the more restricted the design and the bandwidth. This is important in considering 40-channel antenna design.

There are three kinds of loaded mobile antennas; **base loaded**, **center loaded**, and **top loaded**. The top loaded antenna, if it is a true top load, is impractical for mobile service since it requires the use of a large capacitance "hat" to couple it to its mirror image. They were not considered for redesign. The most common type of antenna, the base-load design and the center-load design both have advantages and were redesigned for 40-channel coverage.

Mounting 40-channel antennas

The mounting location of the antenna also has a direct bearing on its performance. The best place to mount any mobile antenna is still the center of the vehicle roof. Trunk or lid mounting with a center location is second best. Other mounting locations tend to distort the pattern, provide restricted mirror image, or reduce effective bandwidth and matching capability. Site election for 40-channel antennas may be somewhat more critical than for 23-channel applications.

With a multiple of variables and design considerations to take into account, design engineers started to develop broadband CB antennas. Keeping antennas as short as possible was still a main criteria.

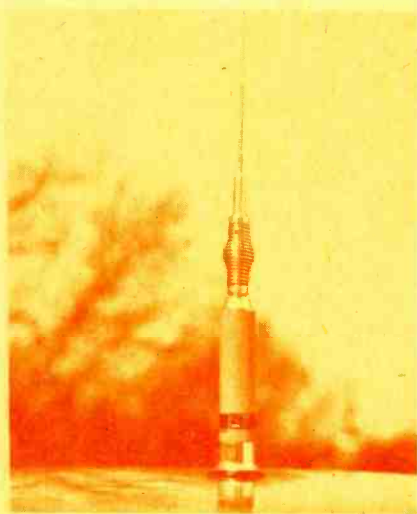

BASE-LOADED WHIP AND SPRING combination. Antenna Specialists model M-125.

Basically, the base-loaded designs were changed by use of a lower Q coil and a slightly longer tip rod. Q is a measurement of antenna selectivity. In essence, the higher the Q the narrower the bandwidth. Since we are concerned with effective bandwidth, those frequencies on either side of the antenna's resonant frequency, lowering the Q expanded the bandwidth of the anten-

na. Antennas that are broadband will feature a reworked coil and a longer tip rod. They will physically look the same but have bandwidths that approach 700 kHz at a 2:1 VSWR.

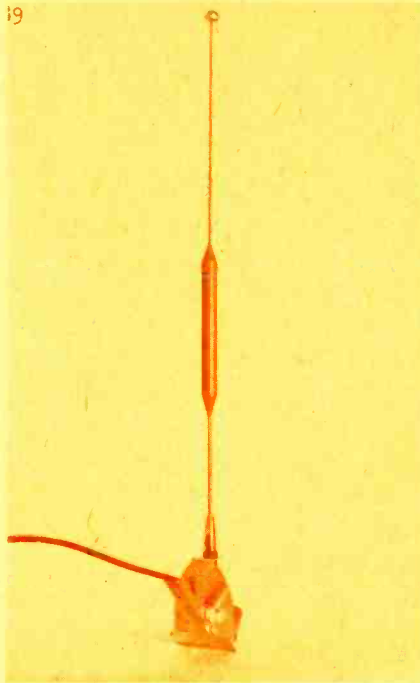

CENTER-LOADED WHIP with gutter mount. Antenna Specialists model M-489

Center-load designs involve the different set of design parameters. Broadbanding was accomplished by using a coaxial matching section in series with the feedline. This has caused expanded bandwidth to approach 300 additional kilohertz and makes it possible to cover the entire band. Short center-load antennas, however, will remain narrow-band in configuration.

Since effective bandwidth is a function of VSWR perhaps it would be wise to restate some facts about VSWR. Throughout the past several years, the term VSWR, or more simply SWR, has become greatly overused. There seems to be, currently, a feeling that an SWR ratio of 2:1 is unusable. This could not be further from the truth for actual reflected power at a VSWR of 2:1 is only about 11% of the total radiating power.

What this really means is that signal loss with a VSWR of 2:1 is in the neighborhood of 1/2 of a dB. This is undetectable at either end especially during short-range CB communications. Above 2:1, however, the ratio in its effect changes greatly. No one should be overly concerned with a VSWR in any installation of 2.0:1 since it is a nominal figure and sought by commercial installers.

Any installation variable that changes the design parameters of an antenna can reduce bandwidth and cause an increase in VSWR. Good bonding to the vehicle

body, proper antenna site selection, and care in tuning are most important. Since some applications will call for specific types of mounts for antennas, then any limitation imposed by that requirement should be understood by the user. The new 40-channel designs will work very well with 23-channel equipment. Also, remember that any current antenna will work with 40-channel equipment over any given segment of frequencies.

Short antenna designs such as rain-gutter mounts contain built-in compromises which make their inclusion in 40-channel expansion programs impractical. Again, it is up to the user to determine exactly what his specific needs are in terms of installation requirements and select the antenna which will meet his needs.

Since there is a wide variety of antenna products manufactured, all application needs should be able to be met without significant difficulty. Such designs as dual antennas, provided they are not overly short, foldover mast designs and 108-inch whip configurations are inherently broad banded and will function well in the 40-channel expansion program.



THREE-QUARTER LOADED. Antenna Specialists model MR312

As we enter this new phase of CB, the product which is currently being manufactured to meet the new expansion requirements will provide those using the service with a means of pursuing it with a minimum of fuss. It will be important for the buyer as well as the seller to know what equipment will meet their specific needs. Personal Communications is an ever growing part of the electronics industry and will continue to grow as the need for CB product grows. The additional seventeen channels authorized by the FCC are just the start and as further changes come about, legitimate manufacturers will meet the changing demands. Personal Communications as a means of communicating is here to stay.

R-E

Using PLL for CB Frequency Synthesizers

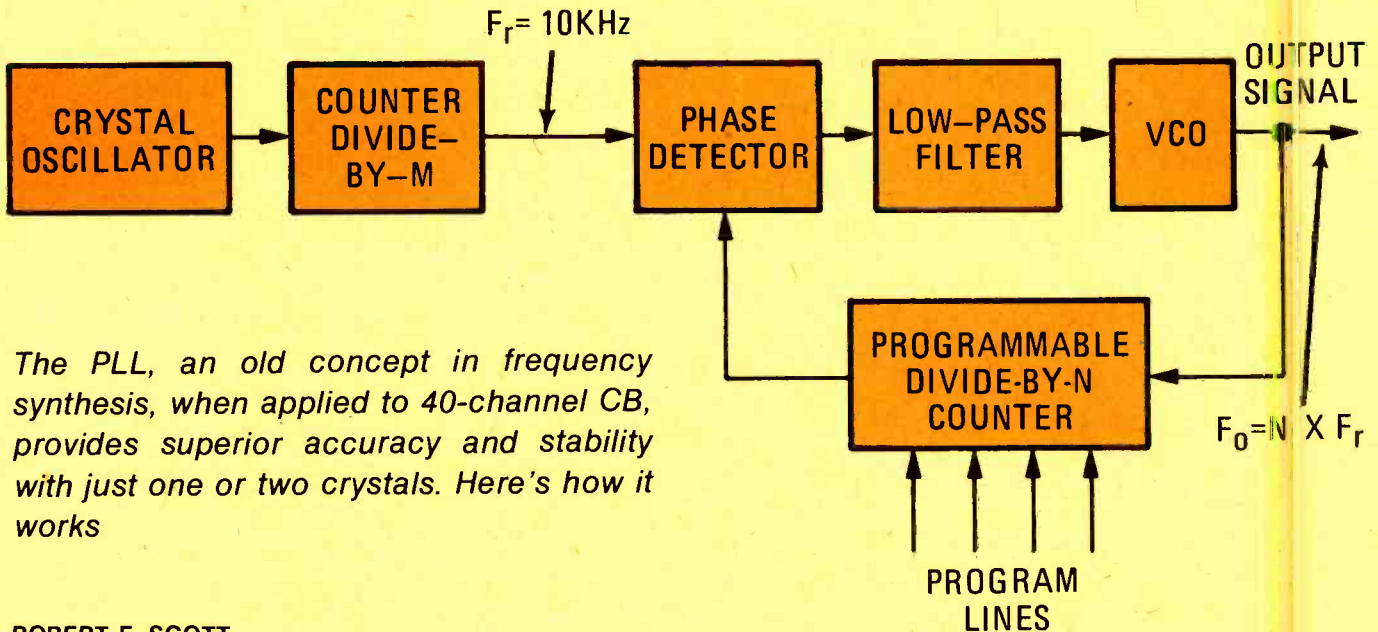

The PLL, an old concept in frequency synthesis, when applied to 40-channel CB, provides superior accuracy and stability with just one or two crystals. Here's how it works

ROBERT F. SCOTT
TECHNICAL EDITOR

WHEN FREQUENCY SYNTHESIS WAS FIRST APPLIED TO CB TRANSCEIVER technology in 1963, it was in the interest of conserving space and providing a higher degree of accuracy and stability in the transmit and receive frequency generating circuits. The twelve or so crystals occupied about one-fourth the space needed for direct frequency control in a 23-channel rig.

When the CB boom hit a couple of years ago, the crystal manufacturers of the world did not have the capacity to make crystals as fast as they were needed for use in CB transceivers. The obvious solution to the problem was to use a frequency synthesis scheme that required a minimum number of crystals. This proved to be the phase-locked loop (PLL) frequency generator that uses from one to three crystals—depending on circuit design.

Just as the PLL frequency synthesizer was gaining a foothold in the top-of-the-line models of some manufacturers, the FCC expanded the Class-D Citizens Radio Service to include seventeen new channels—extending the band up to, and including, 27.405 MHz.

With the crystal shortage still one of the most pressing component procurement problems, the phase-locked loop frequency synthesizer is the only way to go for a manufacturer who wants to remain in the CB transceiver business.

The phase-locked loop

The principle of the phase-locked loop is not new. It was used in some specialized receiver designs developed in the middle 1930's. The most common and most evident application was in the AFC circuits in some of the deluxe AM broadcast receivers of that day. Next came the application of the PLL principle to the synchronization of the vertical and horizontal deflection circuits in TV receivers. Now that we know of two familiar applications of the phase-locked loop, let's see just what it is and how it fits into the CB transceiver design.

Basically, the phase-locked loop is a type of servo-system whose output frequency *locks* onto and follows, or tracks, an input reference signal. The PLL servo system consists of a phase detector, a low-pass loop filter and a voltage-controlled oscillator or VCO. The function of the circuit is to generate an output signal that is an integral multiple of, and in phase with, the input frequency standard.

The input reference signal and the output of the VCO are locked in phase by comparing the phase of the two signals in a detector that converts any phase difference into an error-correcting voltage or current. The error voltage shifts the frequency—and therefore the phase—of the VCO output signal in the direction that causes it to track the input. The basic PLL system is shown in Fig. 1.

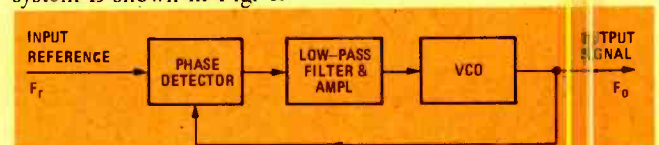

FIG. 1—SIMPLE PLL CIRCUIT produces an output frequency equal to the input reference frequency.

With no reference voltage applied to the phase detector, there is no error voltage at the phase detector output and the VCO runs at its natural free-running frequency as determined by L-C or R-C constants. When a reference signal is fed into the PLL circuit, the phase detector develops two error signal voltages that are proportional to the difference between the reference and VCO signals.

One of the error voltages is the *sum* of the two frequencies—let's call them F_o and F_r , for oscillator frequency and reference frequency, respectively. The other error voltage is determined by the difference between F_o and F_r . The two error signals are passed through the low-pass filter that eliminates $F_o + F_r$, leaving only $F_o - F_r$ as a DC, or near-DC voltage to control

the VCO.

The error voltage reduces the phase, and therefore the frequency, difference between F_o and F_r until the frequencies are exactly the same. However, there will be a small but constant *phase* difference required to generate the error voltage that keeps the VCO and reference signals in lock.

If either the reference or VCO output changes phase, the phase detector and filter produce a DC control voltage that is proportional in magnitude and polarity to the phase change. The error voltage thus produced shifts the phase of the VCO signal by altering its frequency until it again locks onto the reference signal.

About now, you're saying, "So what? If all the VCO does is generate a frequency equal to the reference frequency, what good is it? We would need one precise reference frequency for each of the forty CB channels."

Well, what we have been discussing is the basic PLL frequency generator. In practical multi-channel PLL frequency synthesizers, F_r is a very low value and a programmable frequency divider is inserted in the feedback loop as in Fig. 2.

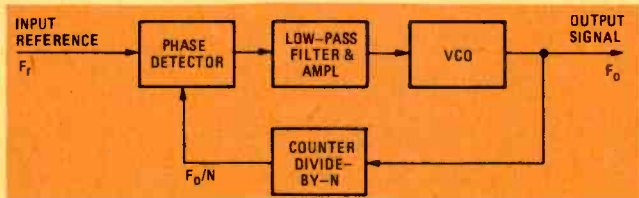

FIG. 2—THE OUTPUT FREQUENCY can be made different from the reference frequency by inserting a divide-by-N counter in the feedback loop. Now the output frequency is equal to $N \times F_r$.

The divider is arranged so it can be made to divide the VCO output frequency by any desired integer N . Phase lock is obtained by comparing the resultant frequency F_o/N with the reference frequency F_r . The phase detector output is now proportional to the difference between F_o/N and F_r .

In most applications, the reference signal is derived from a precision crystal oscillator whose output is fed to a series of frequency dividers. Dividing the crystal frequency by as much as *two thousand* is not uncommon as the resulting reference frequency is usually made equal to the channel spacing—10 kHz except for five 20-kHz gaps. (There are 20-kHz gaps between Channels 3 and 4, 7 and 8, 11 and 12, 15 and 16, and



BOWMAN CB-760 is loaded with features. This 40-channel unit is at the FCC now and should have been approved and available for sale now. Note the use of LED channel readouts.

19 and 20.)

The block diagram of the PLL synthesizer now appears as in Fig. 3. The crystal oscillator frequency is divided by a fixed factor (M) to develop an F_r that equals 10 kHz. The VCO must oscillate at $N \times F_r$ to achieve phase lock. A program-

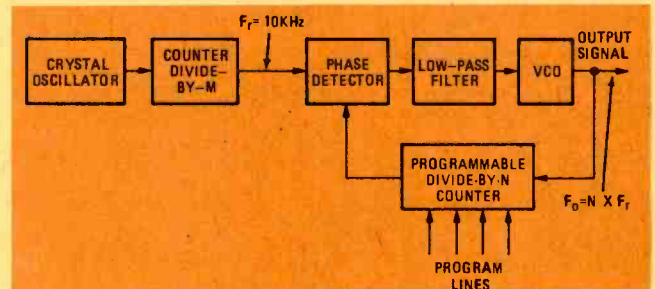

FIG. 3—MULTIPLE OUTPUT FREQUENCIES can be obtained by inserting a programmable divide-by-N counter in the feedback loop. The value of N depends on the data on the program lines.

mable counter is used to select the desired VCO output that is always a multiple of F_r . The divisor N can be derived from BCD switches, keyboard logic or from BCD data from a two-digit 7-segment channel indicator.

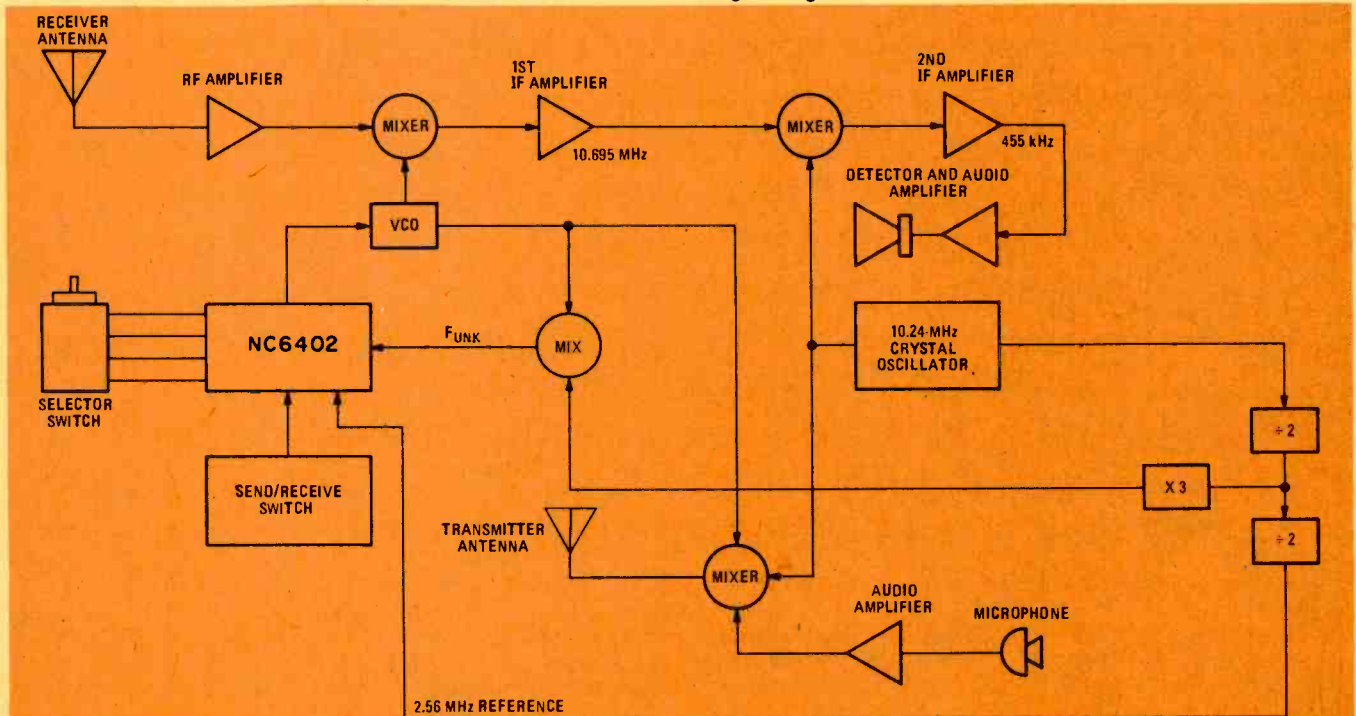

FIG. 4—PLL CIRCUIT of a single-crystal AM CB transceiver.

The CB channel frequencies are not divisible by 10, so various schemes have been used to, in effect, reduce channel spacing and F_r to 5 kHz. In this case (considering circuits that develop the direct signal frequencies for the transmitter) N_{min} equals $F_{o(min)}/F_r$ and F_{max} equals $F_{o(max)}/F_r$. Thus, for Channel 1, N equals 26,965 kHz/5 kHz or 5393. For Channel 40, where N is maximum, N equals 27,405 kHz/5 kHz or 5481.

Most of the earlier PLL frequency synthesizers used in CB transceivers employed large-scale integration and/or discrete semiconductor components along with two or more crystals to generate the precise frequencies needed for the transmitter and receiver circuits. For example, in a transceiver with a single-conversion superhet receiver, one crystal develops the reference voltage. The VCO locks onto F_r and is used to develop the channel frequency for the transmitter circuits.

A second crystal generates a frequency which, when mixed with the VCO output, is used as the injection oscillator frequency to develop the receiver's first IF. A third crystal is used in sets that have dual-conversion receivers. A fourth crystal is needed for sideband selection in SSB transceivers.

Recently, several semiconductor manufacturers developed single-IC frequency synthesizers that require only a single crystal to generate all transmit and receive frequencies. In addition, the devices can be programmed by a simple binary-coded channel selector switch, are compatible with digital display devices, can be used in both single- and double-

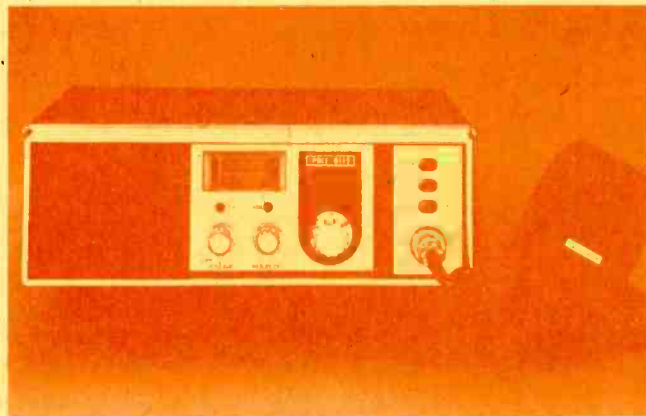

PACE 8115 is a 40-channel unit at the FCC for approval. Can be used on AC in the home or DC on the road. LED channel display. Should be on sale now.

conversion receivers and can provide positive lockout against operation on frequencies not authorized as CB channels.

Among the devices available—but not necessarily used in CB production at this time—are Motorola's XC3390P and the NC6402 by Nitron, a division of McDonnell Douglas Corp. These devices provide all receive and transmit frequencies while positively locking out all other frequencies.

The Nitron synthesizer

The NC6402 is one of a series of PLL-type frequency synthesizer IC's developed for CB applications. It is a 16-pin dual in-line device using N-channel MOS integrated circuitry. A block diagram of a single-crystal, 40-channel AM CB transceiver is in Fig. 4. All that is needed (in addition to the NC6402) for a complete CB frequency synthesizer is one crystal reference oscillator, a single-wafer rotary switch, a dual D-type flip-flop and an optional two-digit, seven-segment display.

The NC6402 interfaces with a two-digit, seven-segment encoded channel-selector switch. Five of the seven lines of the one's digit and three of the seven lines of the ten's digit are used to generate the address codes for the eight input program lines on the IC. Channels are selected by connecting the appropriate inputs to ground. Figure 5 illustrates switch programming.

The SEND/RECEIVE switch (Fig. 4) develops a logic signal to indicate whether the selected channel is in the transmit or receive mode. A logic "1" for receive and a "0" for transmit. The switch simply makes or breaks a connection to ground.

The VCO output terminal on the device varies between +3



GENERAL ELECTRIC 3-5819A has already received FCC approval. It's loaded with features and has an LED channel display. Should be available now.



PRESIDENT'S 40-channel Grant model is pending FCC approval. It's a 40-channel AM-SSB transceiver (that means 120 channels to use).

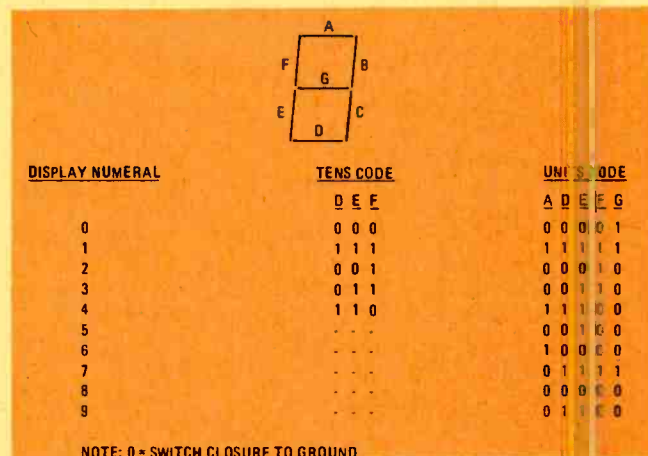

FIG. 5—SWITCH PROGRAMMING of the NC6402 shown in Fig. 4.

volts and ground during the time that the unknown frequency (F_{unk}) is being locked in. It goes to a high-impedance state when the unknown frequency is locked in. The output is positive when F_{unk} is lower than the reference frequency and negative when F_{unk} is higher than the reference. The output current is sufficient to drive a passive low-pass filter and a varactor-tuned VCO.

While you are absorbing this introduction to PLL frequency synthesis for CB transceivers, we will be preparing to describe the Motorola XC3390P and to take a look at the circuitry used in the General Electric model 3-5800A 23-channel rig. R-E

New FCC Rules

ON JULY 27, 1976, THE FEDERAL COMMUNICATIONS Commission (*Charlie*) announced changes in Part 95 of the Rules and Regulations authorizing seventeen additional channels for use on the Class D Citizens band, effective January 1, 1977. In addition, the Commission tightened some of the technical standards for type acceptance and amended some of the sections of the *Rules and Regulations* to clarify the FCC's intent. The sections affected by the changes are 95.3, 95.41, 95.42, 95.49, 95.55 and 95.58. These amended sections are summarized as follows:

95.3 Definitions (b) A Class-D station is now defined as one operated for radiotelephony in the 26.96 to 27.41-MHz band. (The band has been expanded from 27.255 MHz to 27.410 MHz for a bandwidth of 450 kHz. Fifteen of the added channels are spaced 10 kHz apart over the range of 27.255 to 27.405 MHz.)

95.41 Frequencies available. (2) Formerly listed the seven channels used for communications between units of different stations. Now, this section lists the forty channels ranging from 26.965 to 27.405 MHz that may be used for communications between Class D stations, effective January 1, 1977.

The FCC no longer refers to channel numbers—only frequencies. However, the industry has agreed to continue using channel-number designations with channel indicators and selectors noting Channels 1 through 40 as in the table.

(Note that Channels 24 and 25 have been centered in the 30-kHz gap between Channels 22 and 23)

(3) Deleted. Formerly listed Channel 11 (27.085 MHz) for use solely as the calling channel.

95.42 Special provisions. A new section that states that as of September 10, 1976, authorizations for use of frequencies between 26.96 and 27.41 MHz will be issued only to applicants in the Citizens Radio Service. Any license in a

radio service other than the Citizens Radio Service authorizing the use of frequencies between 26.96 and 27.41 MHz shall remain in effect until December 31, 1979.

(Since its inception, the Class D CB service has shared the band—without protection against interference—with medical, industrial, public service and scientific users. No new licenses will be issued in this band except to CB users. Other services sharing the band with CB'ers must vacate the band by December 31, 1979.)

95.49 Emission limitations. (d). This section has been amended to require that the harmonic and other spurious

Frequency	Channel	Frequency	Channel
26.965	1	27.215	21
26.975	2	27.225	22
26.985	3	27.235	24
27.005	4	27.245	25
27.015	5	27.255	23
27.025	6	27.265	26
27.035	7	27.275	27
27.055	8	27.285	28
27.065	9	27.295	29
27.075	10	27.305	30
27.085	11	27.315	31
27.105	12	27.325	32
27.115	13	27.335	33
27.125	14	27.345	34
27.135	15	27.355	35
27.155	16	27.365	36
27.165	17	27.375	37
27.175	18	27.385	38
27.185	19	27.395	39
27.205	20	27.405	40

outputs of a CB transmitter type accepted after September 1, 1976 be attenuated at least 60 dB below the fundamental power output in watts.

95.55 Acceptability of transmitters for licensing. (c) (4). New section. A transmitter capable of operating on any frequency other Class-D CB channels may not be installed or used in any Class D station unless a special license authorizing that transmitter is posted in

the CB station. In other words, if you have a ham transmitter, transceiver or linear amplifier at the CB location, you had better have a valid license posted for the non-CB gear.

95.58 Additional requirements for type acceptance. (c) (2). Multi-channel transmitters shall be capable of operating only on those channels authorized for Class-D CB service. All frequency-determining circuitry and components (other than the channel selector) must be inside the equipment cabinet and not accessible from outside the cabinet or from the control panel.

Add-on devices—whether internal or external to the original equipment—whose function is to increase the frequency coverage of a Class D transmitter beyond its original coverage range, shall not be sold, manufactured or attached to any transmitter designed for Class-D CB use. (No matter what you may have heard, add-on converters or adapters that give you 40-channel performance from a 23-channel rig are illegal and are not to be used.)

If you purchase a new CB rig—either 23 or 40 channels—you'll find a current copy of *Part 95 of Rules and Regulations*, an application blank for a Class-D CB license (FCC Form 505) and a temporary permit (Form 555-B) packed in the carton.

The serial number of every Class-D CB unit sold after January 1, 1977 will be engraved on the unit's chassis. No more gummed stickers or rubber stampings.

Any CB'er causing interference on television Channels 2, 5 or 6, because of spurious emissions from his rig, will be required to install a low-pass filter between the transmitter output and the transmission line that is feeding the antenna.

(All CB'ers would be wise to take a tip from hams who, for years, have used a low-pass filter on their rigs and high-pass filters on their TV sets.) **R-E**

40-CHANNEL ROUNDUP

continued on page 44

in-dash with LED readout; *TD-32* under-dash AM with controls in microphone; *TD-52*, single sideband under-dash, controls in the microphone. Latter two are full-featured, including PLL, LED readout.

"Two or three" of the above expected

to be available for sale toward the end of January, 1977. (P. O. Box 187 Lower Bay Road, Winnisquam, NH 03289)

Tran Sonic

Type accepted: *MCH-41*. No details.

Toyota Motor

Type accepted: *Model 00860-00001*. No details.

Well

Type accepted: *W-605, W-705*.

Windsor

At FCC: Four under-dash units, ranging from \$90 to \$150. (10 Hub Drive, Melville, NY 11746)

Zodiac

"We missed the FCC deadline for January selling. We're not ready yet. We'll let you know when we have 40-channel CBs," said a spokesman. (626 Chrysler Building, New York, NY 10017)

40-Channel Transceiver Directory

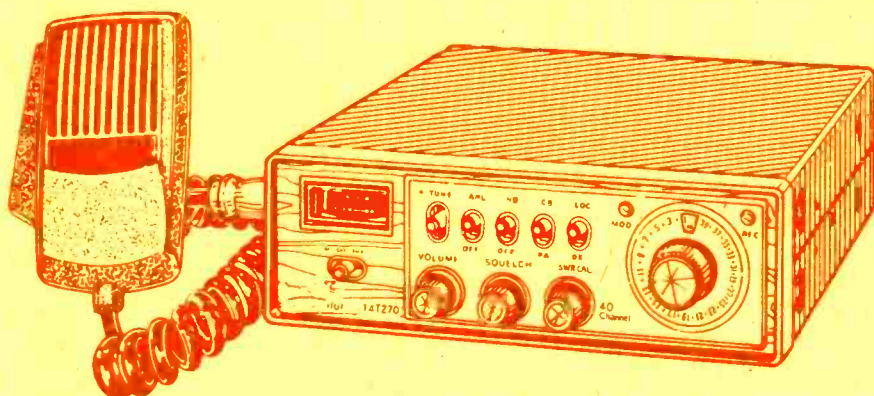

THE COMMISSION (FCC) ANNOUNCED AS OF DECEMBER 6, 1976, samples of the following models of Class D, Citizens Radio Service, 40-channel transceivers have been tested by the Commission Laboratory and found to be in compliance with applicable technical requirements for type acceptance and certification.

As stated in earlier releases, grants of certification and type acceptance for these, and for other transceivers yet to be tested which were submitted by November 1, 1976; will be

mailed in the latter part of December 1976, and will be effective January 1, 1977. Marketing and importation of these transceivers and others is prohibited prior to the effective dates of the type acceptance and certification grants issued. (See Section 2.803 of the Commission's Rules.)

"Future lists of transceiver models found in compliance with Part 15 and Part 95 rule requirements by the Commission Laboratory tests will be issued in the coming weeks." We are told that there are approximately 300 waiting to be tested.

Alpine Electronics Co., Ltd.
Model: BR-640

Audiovox Corporation
150 Marcus Blvd.
Happauge, NY 11787
Model: MCB-3000

Automatic Radio Mfg. Co.
2 Main Street
Melrose, MA 02176
Models: CBH-2265
CB 2176

B & B Import-Export
185 Park Street
Troy, MI 48064
Model: B-4700

Benjamin Electronic Sound Co.
40 Smith St.

Farmingdale, NY 11735
Model: 200

Boman Industries
9300 Hall Road
Downey, CA 90241
Model: CBR-9950
CB-950

Channel Master
Ellenville, NY 12428
Model: CB6835

Colt Communications, Inc.
5725 North Central Ave.
Chicago, IL 60646
Model: Colt 290

Commando Communications Corp.
P.O. Box 11071

Chattanooga, TN 37401
Models: CC4040
CC4086

Craig Corp.
921 West Artesia Blvd.
Compton, CA 90220
Models: L101
L301

Daiei Electric Co. Ltd.
Model: CTI-90

**Dynascan Corp., Cobra
Communications Products**
6460 W. Cortland Avenue
Chicago, IL 60635
Models: 21XLR
89XLR
138XLR
139XLR

Fanon/Courier Corp.
990 South Fair Oaks Ave.
Pasadena, CA 91105
Models: Fanfare 100F
Rebel 40
Conqueror 40D
Fanfare 880DF

Fukuyama Electronics Co. Ltd.
Model: FKCB001A

Gemtronics
356 South Blvd.
Lake City, SC 29560
Models: GTX-44
GTX-55

General Electric Co.
Electronics Park
Building 5
Syracuse, NY 13201
Models: 3-5801A
3-5811A
3-5811B
3-5812A
3-5819A
3-5821A
3-5825A

General Motors Corp.
Models: GM CBD-10A
GM CBD-20A

Hitachi Sales Corp. of America
401 W. Artesia Blvd.
Compton, CA 90220
Models: CM-2410H
CM-4850H

Hy-Gain Electronics Corp.
8601 Northeast Highway 6
Lincoln, NB 68507
Models: 682A
2700
2702
2703
2705
2679A

Ray Jefferson
Main and Cotton
Philadelphia, PA 19128
Model: CB-740

Kraco Enterprises, Inc.
505 East Euclid Avenue
Compton, CA 90224
Models: KCB-4003
KCB-4005
KCB-4010
KCB-4020
KCB-4030
KCB-4040
KCB-4088
KCB-4075

Kris, Inc.
N144 W5660 Pioneer Rd.
Cedarburg, WI 53012
Models: XL-45
XL-23A

Kyodo Communications & Electronics
Models: Sawtron 770
Sawtron 790

Lafayette Radio/ Electronics Corp.
111 Jericho Turnpike
Syosset, NY 11791
Models: HB-640
HB-740
HB-940

Mars Radio Corp.
1420 Rodondo Beach Blvd.
Gardena, CA 90274
Models: CON-400
CON-450
M-368
M-374
M-375
M-379

The Panasonic Company
One Panasonic Way
Secaucus, NJ 07094
Models: CR-B4700EU
CR-B4701EU
CR-B4747EU
CR-B4748EU
CR-B4247EU
CR-B4737EU

Maxon Electronics Co., Ltd.
Sunrise Highway
Great River, NY 11739
Model: Maxon 40

Meishoh Electronics Co., Ltd.
Models: ME-400
ME-402
ME-401A

Meriton Electronics, Inc.
35 Oxford Drive
Moonachie, NJ 07074
Models: RS-5111

Midland International Corp.
P.O. Box 1903
Kansas City, MO 64171
Models: 63-240
77-853
77-857
77-882
77-883
77-888
77-955
77-825

**Pathcom, Inc.; Pace
Communications Division**
24049 S. Frampton Avenue
Harbor City, CA 90710
Models: 1000B
8041
2300CA

CB-166
8015A
8010A

Pearce-Simpson, Inc.
4701 N.W. 77th Ave.
Miami, FL 33152
Models: Super Cougar 40
Super Cat 40
Super Tiger 40
Tiger 40

J. C. Penney Co.
Models: 6203
6237

Pioneer Electronics Corp.
1555 East Del Amo Boulevard
Carson, CA 90746
Models: GT-6600
GT-1100

President Electronics, Inc.
16691 Hale Avenue
Irvine, CA 92714
Models: Dwight D
Zachary T
Honest Abe
Teddy R

Radio Shack
2617 West 7th Street
Fort Worth, TX 76107
Models: 21-1520
21-1521
21-1524
21-1526
21-1542
21-1562
21-1580

RCA Corporation
Cherry Hill Offices
Bldg. 206-2
Camden, NJ 08101
Models: 14T270
14T304

Regency Electronics, Inc.
7707 Records Street
Indianapolis, IN 46226
Models: CR-430
CR-485
CR-486

Royce Electronics, Inc.
1746 Levee Rd.
North Kansas City, MO 64116
Models: 1-648
1-675

Sanyo Electric Co. Ltd.
1200 West Artesia Blvd.
Compton, CA 90220
Model: IA-4000

SBE, Inc.
 220 Airport Blvd.
 Watsonville, CA 95076
 Models: Brute 40
 SBE-43CB

M.H. Scott Co. Inc.
 Model: DAK MARK 3A

Sears, Roebuck & Co.
 Models: 2862674
 2862676
 CM 2378SA
 CM 6000LA
 CM 6000LB
 CM 6100S
 CM 6200S
 TA 4501
 CB-4700S

Shakespeare Company
 P.O. Box 246
 Columbia, SC 29202
 Model: GBS-240

Sharp Electronics Corp.
 10 Keystone Place

Paramus, NJ 07652
 Models: CB-2260
 CB-2460

Sony Corp. of America
 9 West 57th Street
 New York, NY 10019
 Model: ICB-2500

Standard Communications Corp.
 P.O. Box 92151
 Los Angeles, CA 90009
 Model: Horizon 2900

Superscope, Inc.
 8150 Vineland Avenue
 Sun Valley, CA 91352
 Models: CB-340
 CB-140

Teaberry Electronics Corp.
 6330 Castleplace Drive
 Indianapolis, IN 46250
 Models: 4001
 4002
 4006

Toyota Motor Sales USA, Inc.
 Models: 00860-00001
 00860-00020

Tran Sonic Industries, Inc.
 P.O. Box 326
 Lexington, MA 02173
 Model: MCB-41

Uniden Corporation
 Model: 805

Well, Inc.
 Models: W-605
 W-705

Western Auto Supply Co.
 2107 Grand Avenue
 Kansas City, MO 64108
 Models: CYJ4832A-87
 CYJ4834A-87
 CYJ4837A-87
 CYJ4862A-87

R-E



TRAM model D62



COURIER Spartan PLL40

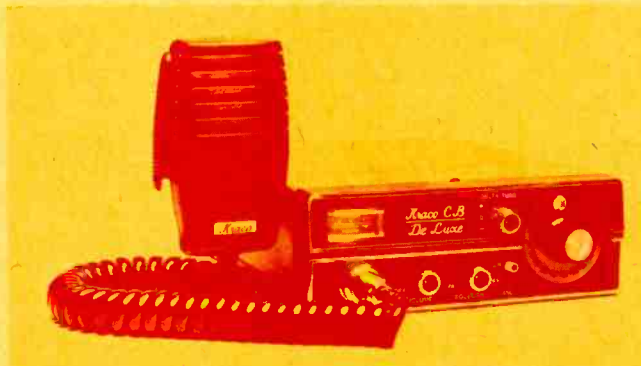

KRACO model KCB-4020 (above)

RCA model 14T270 (below)



PACE model 8025

New Solderless Coax Connector

FRED SHUNAMAN

IN THE "FIRST SIGNIFICANT IMPROVEMENT IN CB CONNECTORS since the now-standard PL-259 first became available in 1941," Bunker Ramo's RF division has introduced a new, no-solder RG-58 A/U termination that requires no special tools nor training for installation. The new, reusable Amphenol 83-58FCP (field crimp plug) is useful in both base and mobile installations and will be widely used in CB antennas, accessories, and all similar applications that use RG-58 A/U coax.

Not only does the new connector reduce the time and labor required to install connectors—it makes better connections, especially on connectors installed in the field. This cuts down on one of the biggest present causes of radio system failures—faulty interconnections.

"Overheating and the damage it causes has been an often-unavoidable consequence of soldering," points out Lee E. Eichenseer, vice president of Bunker Ramo's RF division. "Until now, there has not been a fast, simple means of making reliable connector-to-cable connections. Previously-available solderless connectors required special crimping tools and in many cases their performance was unsatisfactory.

"The new Amphenol 83-58FCP is the first connector to solve all these problems. It offers performance equal to that of standard Amphenol 83-1SP connectors, at the same price."

The specs are indeed equivalent to those of older types. The 83-58FCP has a frequency range of 0-300 MHz and a voltage peak of 500. The thermal limits are -67 to +300 degrees F (149 degrees C). The connectors have standard 1/8-24 threads and mate with regular UHF receptacles and adapters. They are not waterproof.

Not only are the new connectors offered for field use, but for manufactured equipment as well. They are being made in OEM (Original Equipment Manufacturer) quantities and, according to Mr. Eichenseer, will soon start appearing on CB products offered by various leading accessory, coaxial line and antenna manufacturers.

R-E



STEP 1—SLIDE THE OUTER FERRULE and the coupling nut onto the trimmed cable. Fan the braid out slightly by rotating the insulation. Slide the body assembly over the center conductor of the cable.



STEP 2—PUSH THE BODY ASSEMBLY over the cable so that the barrel goes over the dielectric but under the braid.

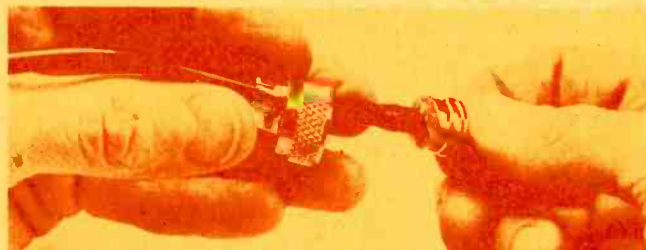

STEP 3—POSITION THE BODY so the braid flattens against its rear flange.



STEP 4—SLIDE THE COUPLING NUT up over the body assembly. Grasp the cable with one hand and push the ferrule forward with the other until it snaps into place.

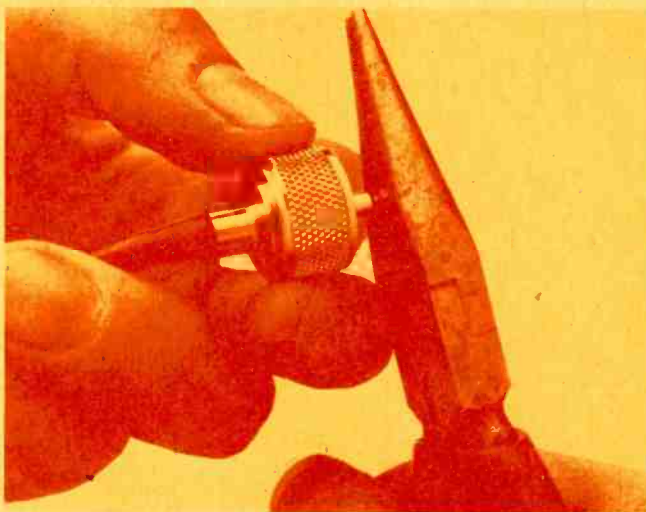

STEP 5—SQUEEZE-CRIMP THE TIP of the center conductor only, with the pliers. If the connector is to be used again, the center contact may be soldered.

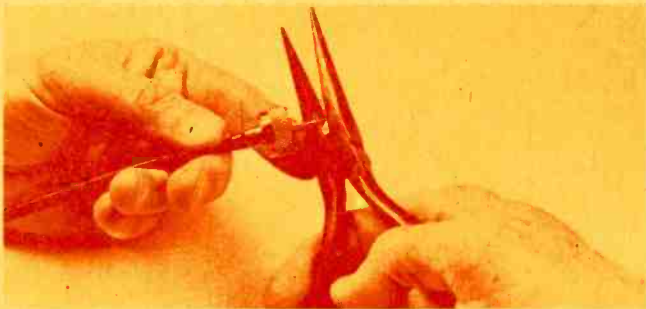

STEP 6—TRIM OFF THE TIP of the coax center conductor to flush it with the barrel.

COLOR TV

What's New for '77

*A look at what the
new year has brought us
in terms of circuitry,
performance and features.*

KARL SAVON
SEMICONDUCTOR EDITOR

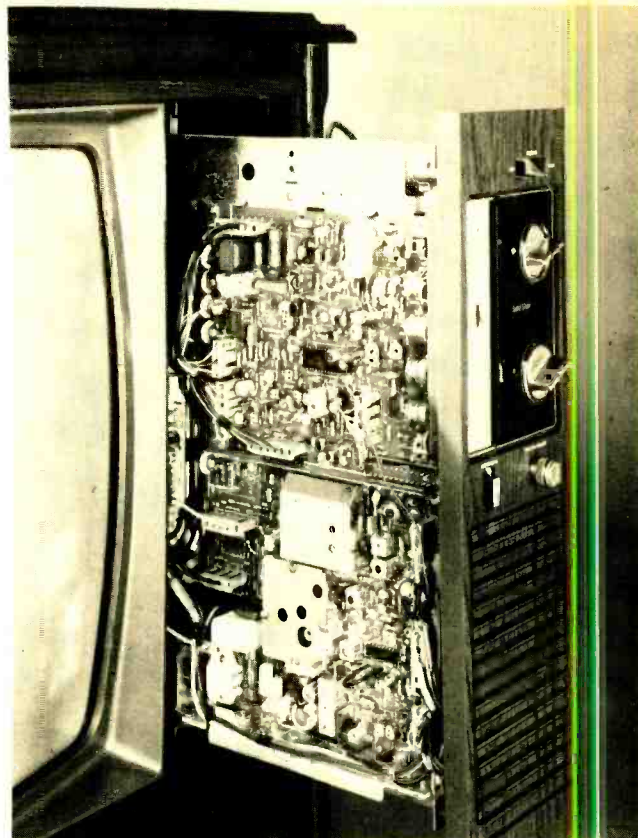

CONTINUAL PICTURE TUBE DEVELOPMENT, solid-state techniques and the integrated circuit have matured color TV receivers into truly reliable high-performance instruments. Manufacturers are bringing performance enhancements from the research lab into the latest products.

Progress has been made in such areas as electronic tuning with a system that the customer can install, in flesh tone correction by a system that changes only the flesh tones, and in power management by reduction in power consumption to the 100-watt level.

Though the frequency of servicing over a period has been statistically reduced, new problems have been created by the increasingly complex technology. New product innovations are slanted toward making set repair quicker and more systematic.

Broadcasters and set manufacturers are cooperating by recognizing the amazingly few weaknesses in the color broadcasting standards as originally devised. They have come up with an experimental system that subdues one of the deficiencies.

Quasar

Servicing solid-state receivers can be a very frustrating experience. Very special parts (triacs, integrated circuits) are encountered more and more. Unless you are a service organization specializing in one or two brands, these parts are probably not on your shelves. The trend makes it more difficult for the small service company to stay alive.

Quasar has made a two-front attack on the related problems of serviceability and reliability by the introduction of the "Super Module" and new integrated circuits.

Modular chassis are becoming universal, but Quasar's new Super Module retains the basic concept while making it more practical for a consumer product. The signal package is designed into a single replaceable panel. It

performs most of the low-level signal and video processing in designated 1977 models. One module fits all applicable console, table, and varactor and nonvaractor tuned models. As much as 75 percent of the total chassis circuitry is on the module. It plugs into "Works in a Drawer" consoles, continuing the convenience of servicing from the front of the set. To free the panel from the chassis, remove six Phillips head screws and unplug the connectors.

The concept of replacing a large chunk of the receiver in a couple of minutes, with one large module instead of five or six smaller ones, means many fewer plug-and-socket connections. Each pin eliminated is one less spot where corroded or bent pins can cause trouble. Secondary controls mount directly on the module, reducing the number of connections as well as the wiring to the components.

Five integrated circuits in the IF, AFT,

sound video, and color sections reduce the component count and the interconnections, again significantly contributing to reliability.

Figure 1 is the block diagram of the TS958/959 receivers. The first two stages of IF amplification and the AGC functions are contained in IC101. Based on sync amplitude, the IC generates automatic gain control signals for the 1st and 2nd IF stages. Both AGC polarities are available for forward-biased mechanical and reverse-biased varactor tuners.

Video processor IC301 accepts the output of the delay line and amplifies the signal. Brightness and sharpness corrections from the viewer controls are performed by IC301 which then feeds video driver transistor Q303. Noise inverter and sync separator stages in IC301 process the video and produce sync outputs for the horizontal AFC and vertical blocking oscillator circuits.

Color processor IC601 takes the video from emitter follower Q301. ACC (Automatic Color Control) helps maintain the chroma level selected by the color intensity control. Demodulated red, green, and blue color difference signals feed the bases of the video output transistors on the picture tube socket (the emitters of the output transistors are driven with the luminance signal from video driver Q303. Relatively few external components surround IC601.

The fifth monolithic device, IC201, takes the 4.5-MHz output from the sound detector and frequency demodulates the audio information. Two audio preamplifier stages increase the detected signal to the necessary level to drive the audio output transistor Q201.

An outstanding accomplishment of the designers of the two Super Module chassis is the low power consumption. The TS958 25-inch models consume 110 watts and the

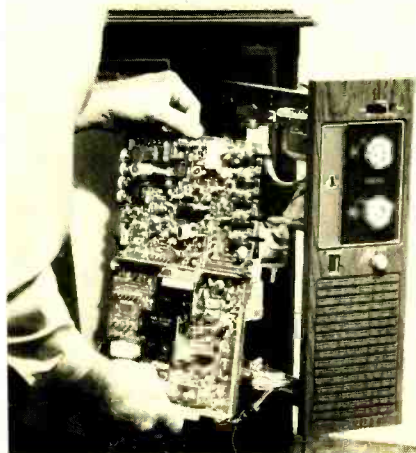

THE QUASAR PLUG-IN SUPER MODULE.

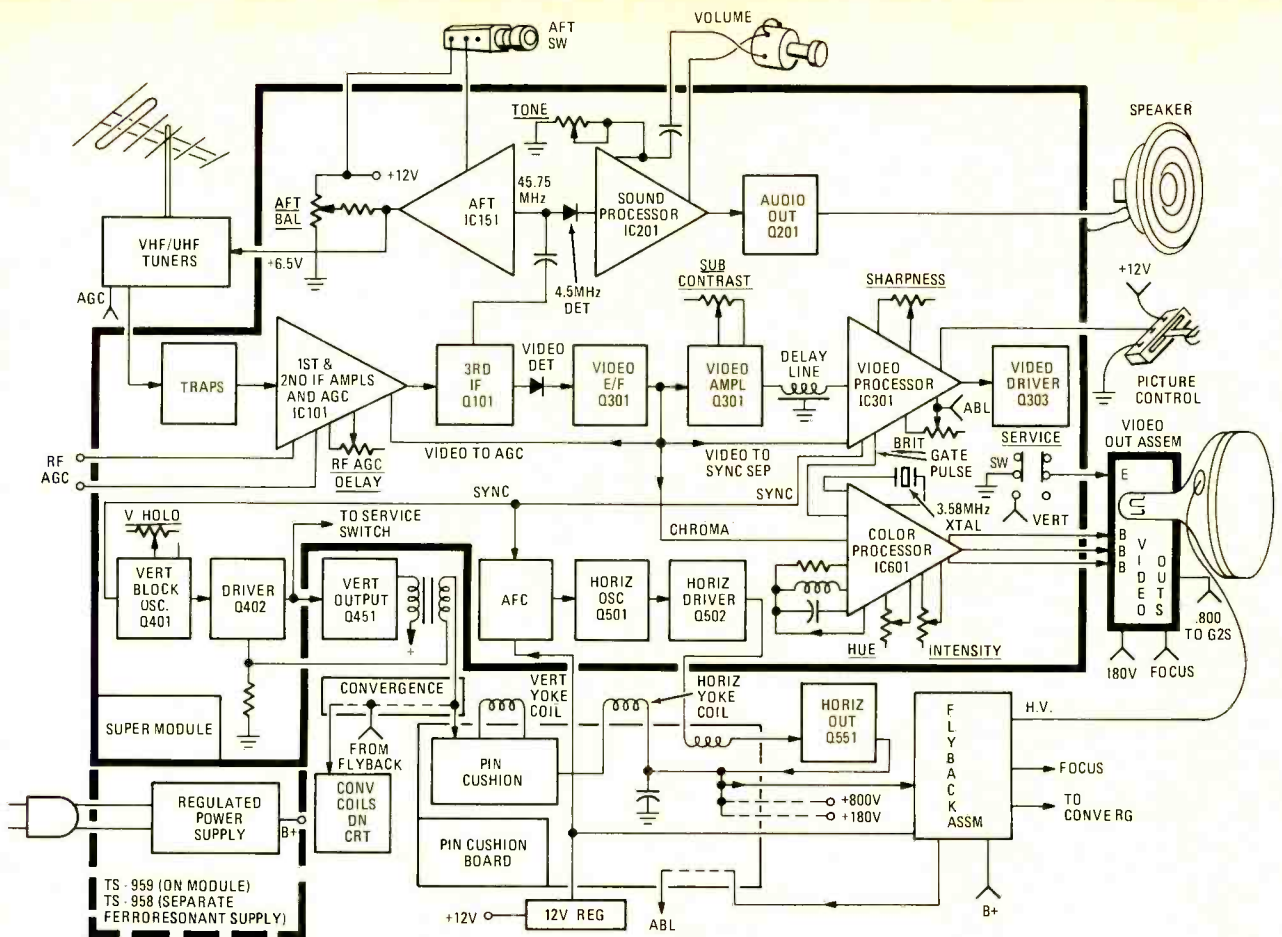

FIG. 1—BLOCK DIAGRAM, QUASAR TS958/959, showing Super Module.

TS959 19-inch sets use only 88 watts! The TS958 has a ferroresonant transformer for voltage regulation. Solid-state electronic regulation is featured in the TS959.

RCA receivers

RCA's new models have a number of innovative features. The top of the line direct-access tuning system with a calculator-type remote control keyboard is continued from last year. A dynamic flesh tone correction circuit has all the advantages of the older

breed of color correction circuits but does not introduce the color distortion to colors removed in phase from the range of flesh tones. And a new luminance system optimizes sharp peaking adjustment and produces a sharp picture with improved resolution.

Flesh correction circuits generally distort the color signal. Some colors may be shifted more than others and overall phase corrections inadvertently shift correct colors as well as incorrect hues. RCA's new system restricts the correction to colors closest to the +1

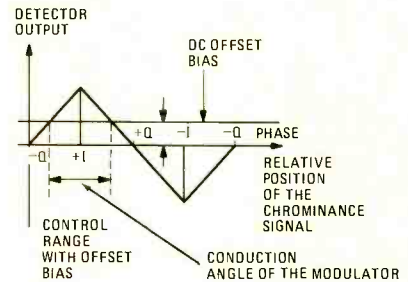

FIG. 2—OFFSET BIAS CONFINES color correction to colors near flesh tones.

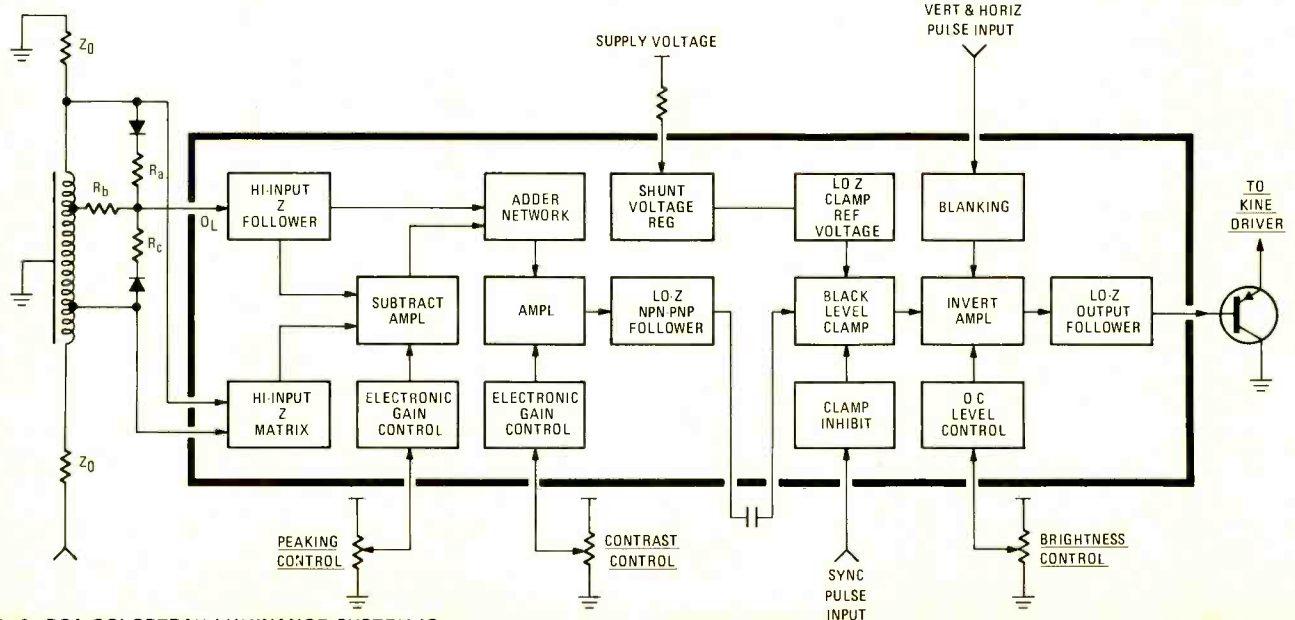

FIG. 3—RCA COLORTRAK LUMINANCE SYSTEM IC.

vectors near the flesh tones. Pure reds, blues, greens and normal flesh tones are minimally affected. Magenta and yellow-green color components are the "off flesh tones" that are shifted in phase toward the +I direction.

The dynamic correction system amplitude limits the chroma signal and compares it to the color subcarrier with a phase comparator. At this point the corrections exist for all colors not on the I axis. The phase comparator output is gated in a modulator to produce an output that is added to the color subcarrier before it is used by the Q and I demodulators. Figure 2 shows the action of the modulator. An offset bias applied to the modulator blocks the color corrections for colors outside the portion of the spectrum near flesh colors.

The block diagram of the Colortrak luminance system is shown in Fig. 3. A new integrated circuit produces a unique combination of functions including DC controlled phase corrected peaking, nonlinear transient compression in the white direction, and true black level clamping.

Optimum video transient response has one preshoot and a matching overshoot. Until now, the techniques used in TV receivers have not produced this ideal response. The new RCA sets use a transversal filter system that adds the signals from taps on an otherwise conventional delay line. A high-frequency signal is generated by adding the voltages from the taps closest to the ends of the delay line. By adding or subtracting the high frequency signal from the output of the center tap, a variable peaked signal is formed while maintaining the ideal transient response.

As illustrated in Figure 3, one input to the peaking system is picked off the end of the delay line so only two actual taps are needed.

Zenith

New Zenith engineering advances for 1977 include a 19-inch diagonal Chromacolor 100-degree picture tube with the high-resolution EFL electron gun. The patented EFL gun focuses the electron beam with four instead

of two electron lens elements, reducing spot size up to 60% compared with conventional guns. Improved picture sharpness and high-light detail is the result.

Also new is the Color Sentry automatic picture control system that ties together five electronic circuits to adjust the color, level, saturation, tint, color balance, and other parameters automatically. Color Sentry adjusts the picture when changing channels or any other time the program material is altered.

Up to 12 VHF or UHF channels are selected with the touch of a button with Zenith's Touch-Command. Married to the Electronic Video Guard tuning system, light pressure on the selected channel button brings in the viewer's choice without the distraction of passing through other stations. Electronic Video Guard tuning is in 85% of Zenith's color line which is the broadest use of electronic tuning in the industry.

Admiral

The Admiral Group of Rockwell International Corporation has a new line with a 100 percent deluxe solid-state television chassis. The ERA II Limited chassis features the industry's first optional electronic remote control that can be installed by the customer. The suggested retail price of the tuning system is \$99.95. A SELECT button on the calculator type keyboard enters the previously keyed-in channel number. Apparently this is Admiral's way of dealing with the problem



THE SEVEN MODULES of the Admiral ERA II can be changed in seconds.

of differentiating between one and two-digit channel entries.

Remote control can be added to five sets that have the built-in adapter. The remote transmitter is a duplicate of the tuning panel on the set. Installation consists of simply plugging the unit into the adapter after removing the cover plate on the front of the receiver. A 9-volt battery is inserted in the transmitter and the system is in operation.

The ERA II Limited remote transmitter has a self-checking system that indicates battery condition. If the battery is strong, pressing the SELECT button causes the least significant digit on the receiver's digital display to flash. When the battery is weak, the lower digit stops winking.

The Admiral ERA II Limited chassis is offered in certain 23 and 25-inch consoles. They feature a negative black-matrix picture tube and ambient light sensing. Some 20-inch models are equipped with a digital channel read-out display.

All complex parts, including the power supply and the high-voltage deflection system, have been designed into efficient compact units. Each module is computer tested before installation at the factory.

General Electric

G-E also has an industry first for 1977. It is the 25-inch in-line gun picture tube used in the new YM chassis. One of the main features of the in-line picture tube is the simplified convergence procedure that G-E calls the "4 minute half hour."

The big G-E feature for 1977 is the VIR "Broadcast Controlled" Color system. Details of the experimental Vertical Interval Reference system are described in the November, 1976, issue of **Radio-Electronics**. As explained in the article, General Electric uses tint and color controllers to compare the received luminance and color signals with information extracted from the VIR signal. The VIR reference was carefully designed to allow easy correction for transmission distortions. The signal format is such that it is relatively unaffected by the transmission errors that affect the color burst reference phase and amplitude.

Figure 4 is the schematic of the tint controller and demonstrates the principle of both the phase and amplitude correction mechanisms.

The R-Y color difference signal from the chroma/video module feeds the base circuit of emitter follower Q38. Limiting the bandwidth with R37 and C37 reduces noise. Transistor Q38 drives Q41 and Q42 when the signals are allowed through by the intervening diode gates. The lower switching diode-gate (diode D39) is controlled by the chroma reference interval and the upper gate (D40) by the black reference interval key-pulses developed in the line recognizer section of the system. The line recognizer detects the nineteenth picture line where the VIR signal is located and extracts the chroma and luminance levels from the appropriate signal segments.

When the cathode of either D39 or D40 is at ground potential, the corresponding anode is one V_{be} above ground and the bases of the transistors at ground potential holding them off. One V_{be} is insufficient to forward-bias the two-junction combination of the series diodes D42 or D41 and the base-emitter junction of transistor Q41 or Q42. Positive

continued on page 84

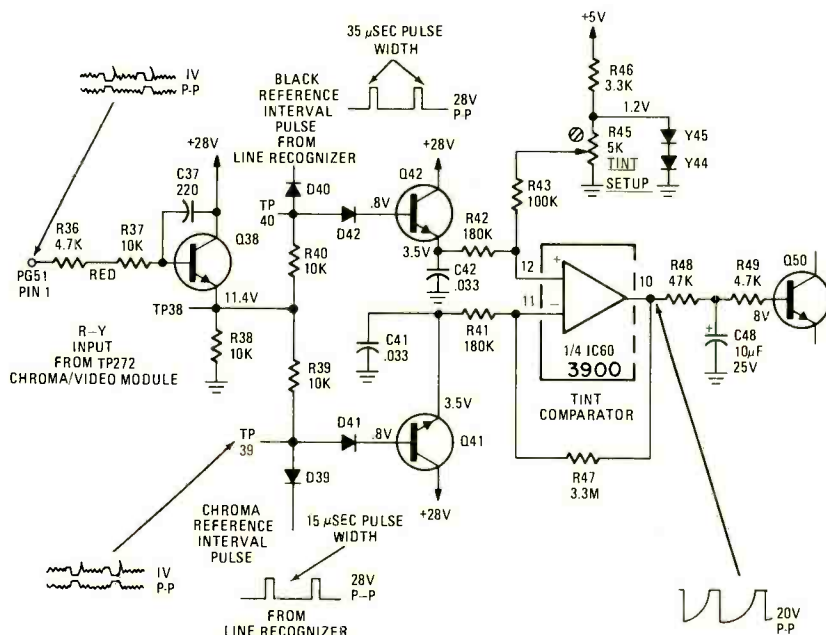

FIG. 4—GENERAL ELECTRIC VIR TINT COMPARATOR.



Build Portable Mini-Organ

JOHN S. SIMONTON, JR.

Part II. Play music anywhere with this self-contained battery-powered mini-organ. It has its own keyboard, speaker, a unique pitch-bender and covers a five octave range

LAST MONTH, PART I OF THIS ARTICLE introduced Oz and presented the schematic, foil patterns and began the construction details.

This month, the article concludes with the rest of the construction details and a description of how to connect and use Oz.

Mount the circuit board, keyboard and front panel in the housing that you've built or purchased. (Another tip: build a box, then cut it in halves or quarters or whatever, to make it open; don't cut the pieces first then try to put them together so that they form a closing box.) Then wire the connections between the circuit board and front panel (see Fig. 6). The caveats that I mentioned for PC board to keyboard wiring apply equally here. Leave enough slack so if something breaks, it can be fixed without dismantling the entire thing—but not so long that radiation problems pop up.

That makes twice that I've mentioned "radiation problems." Conceivably some of you are wondering what that means. It means this: as we've already

noted, the output of the top-octave IC is a bunch of squarewaves. I might now mention that these squarewaves have very respectable rise and fall times. When we have fast rise and fall times, Mr. Fourier tells us that we will have high-frequency components. Mr. Maxwell tells us that high frequencies have a great ability for launching themselves into space in the form of electromagnetic radiation. The longer the wire that these high frequencies have to pass through, the greater will be their ability to leave the conductor entirely.

Similarly, long wires connected to the input of an amplifier will act as antennas that pick up the radiation and amplify it just as it would any other signal. The net result, in this case, is that notes work their way from the tone-generating circuitry to the amplifier and speaker without bothering to go through the keyboard. It becomes our task, then, either to prevent the radiation to whatever extent possible (short wires); or, failing that, to at least contain the radiation (shielding). Besides short wires there are a couple of other things that

you can do to minimize—and probably eliminate entirely—this problem.

Use coax to make the connections indicated to be coax on the schematic and in the illustrations: specifically, the signal path from keyboard to front panel and back to the circuit board.

It is not practical to use coax to make all the connections between the circuit board and keyboard; but fortunately it's not necessary either. Most keyboards have a solder lug attached to their frame somewhere. It's there for a purpose—the purpose being that if you ground it, the whole frame of the keyboard becomes one big shield to prevent radiation spilling out into places it shouldn't. Point "BB" on the PC board is ground and has been provided for just this purpose.

Just a little more, we're almost done. Special note also needs to be given to the pitch-bender panel. If you really want to, you can eliminate it entirely simply by not wiring it in (in which case it would not hurt to parallel an additional 47 pF across C20). But the ability to tremolo and "glide" single notes and chords is to a great extent what OZ is all about, so I will assume you are going to use it. Connect the pitch bender panel to the rest of the circuitry with small diameter coax, like RG-174/U. Coax is important here because we're working with an element that is capacitance sensitive and we want to minimize the effect that grabbing the connecting cord with your hand will have. The most important part of using coax is to make sure that the shield goes to the *driving* terminal of the clock circuit (the output of IC6-b—point "L" on the circuit board). Figure 7 shows the assembly of

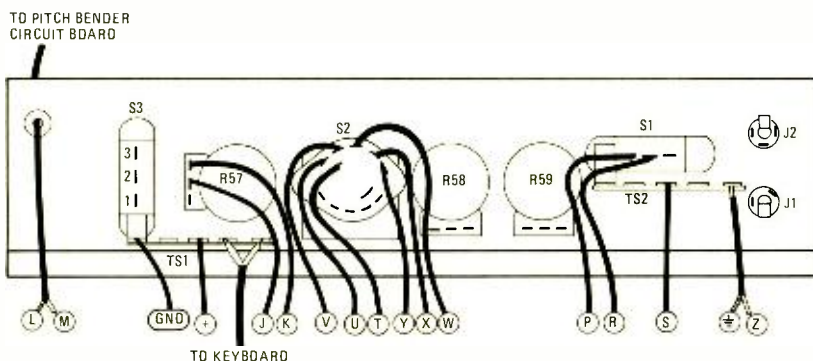
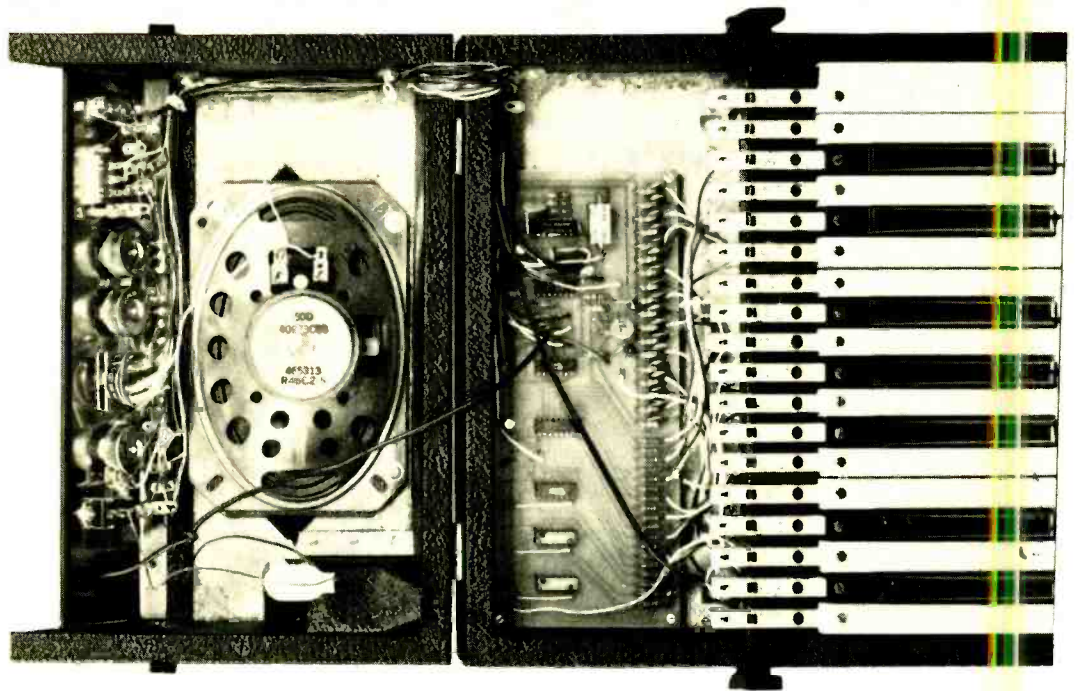

FIG. 6—PANEL-TO-BOARD WIRING.



the pitch bender panel.

You're finished. Now, before you hook up the batteries, why don't you check it through one more time? I always do (well, almost always).

OZ requires a 12-volt power source for proper operation. This can be a line-operated supply if you like, but be aware that a portion of the audio bus is connected to the supply lines, so power supply ripple rejection at the output is low. Make sure the supply is well filtered.

The best bet is batteries. "AA" size cells work well and even taking into account OZ's 60-mA typical current drain, a fresh set of quality batteries should last for a month or more of daily intermittent operation.

Testing

Turn the POWER switch ON and observe that one and only one of the range indicating LED's lights. Change the OCTAVE switch and observe that the LED's follow the action of the switch.

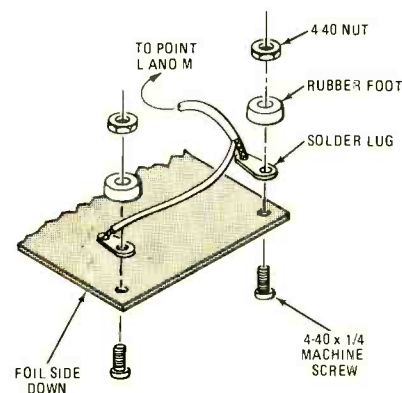

FIG. 7—PITCH-BENDER board assembly.

Depress one of the keys and advance the LEVEL control until a tone is heard from the speaker. Test all the keys to make sure they produce a tone and that the pitch of the tone ascends as you work your way up the keyboard. Confirm that all positions of the OCTAVE switch work and that as the knob is advanced in a clockwise direction the pitch produced changes by octave steps.

While pressing keys, check the operation of the trigger status LED. With the TRIGGER select switch in the STEP position, the LED should come on and stay on as long as any keys are down. In the pulse position of this switch, the LED should wink briefly (very briefly) every time a new key is pressed down.

Try connecting the tone-generation circuitry to an external amplifier by connecting the OUT jack J2 into the input of the outboard amplifier. Under these conditions make sure that signal is being supplied to the external amplifier and that no sound is coming from OZ's speaker.

To test OZ's input jack, you can either run an external program source into J1 (IN) or you can just jumper from OZ's output to its input. If, under these conditions, you still hear sound from the speaker, then the IN jack is working.

Using OZ

There is little to be said about using OZ by itself. You simply turn it on, select the octave that you want to play in, set the LEVEL and TONE controls to your taste and wail!

Interfacing to full synthesizer systems is only slightly more complicated, and more than anything else, requires that

you have a firm grasp of exactly what OZ is and what it is supposed to do. Let's pin that down right now: OZ is a combination controller and polytonic pitch source. Nothing more (it doesn't need to be anything more). In most synthesizer systems, it will be used in place of—or possibly in conjunction with—a keyboard/voltage controlled oscillator combination.

For example, Fig. 8 shows a "classic" synthesizer configuration. In a patching arrangement like this, there are really two different circuits with which we need to be concerned: the control circuit (triggers, control voltages, etc.) and the audio circuit (outputs of oscillators, inputs and outputs of voltage controlled filters and amplifiers, etc.). In the scheme illustrated, the control circuit can also be broken down into control

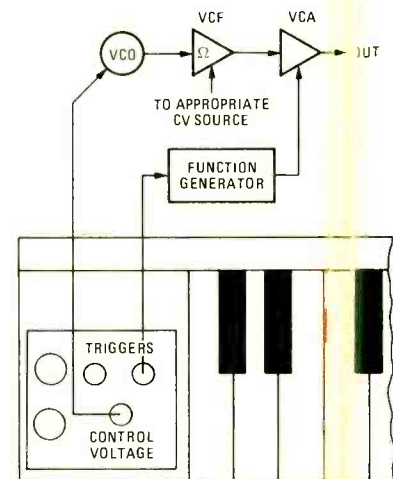

FIG. 8—A SYNTHESIZER PATCH. The initials stand for voltage controlled oscillator, filter, amplifier, and control voltage source.

PARTS LIST

All resistors 1/2 watt, 10%.

R1-R18—330,000 ohms
 R19-R36, R51, R53, R54—22,000 ohms
 R37—33,000 ohms
 R38—3.9 megohm
 R39—150,000 ohms
 R40, R41, R56, R60—10,000 ohms
 R42—2700 ohms
 R43—680,000 ohms
 R44—100,000 ohms
 R45, R46, R47—10 ohms
 R48, R52, R55—2200 ohms
 R49—4700 ohms
 R50—1000 ohms
 R57, R58, R59—5000-ohm potentiometers
 C1-C18, C24—.005 μ F, ceramic disc
 C19, C22, C26, C31—.05 μ F
 C20—47 pF
 C21, C28, C29, C30—.01 μ F

C23—100 pF
 C25, C32—1 μ F, 12-volt electrolytic
 C27—250 μ F, 12 V
 C33—0.22 μ F, Mylar
 D1—1N914 diode
 IC1, IC2, IC3—CD4013
 IC4—MK-50240
 IC5—CD4024
 IC6—CD4001
 IC7—LM380
 J1—miniature open circuit phone jack
 J2—miniature closed circuit phone jack
 J3—pin jack
 LED's (6)—MSL-7-50 light-emitting diode
 Q1, Q2—2N5129 or 2N3904 transistor
 S1, S3—SPST slide switch
 S2—2P5T rotary switch
 Keyboard—18-note DPST switching
 Miscellaneous hardware, 4 knobs, front panel, vinyl covered case, 8-

ohm speaker, speaker bezel, grille cloth, two 5-lug terminal strips, wire, plastic tubing, coaxial cable, bare wire, cable clamps, wire ties, printed circuit board, LED circuit board, pitch-bender circuit board.

A complete kit of parts to build OZ, including case, PC boards, keyboard, etc, less batteries, is available from:

PAIA Electronics, Inc.

P. O. Box 14359

Oklahoma City, OK 73114

for \$84.95 plus shipping and insurance for 12 lbs. Order No. 3760

A set of three circuit boards may be obtained for \$10.00 postpaid. Order No. 3760 PC.

The keyboard is available for \$39.00 including postage and handling. Order No. AGO-18.

voltages and triggers. When a key is depressed on the keyboard, a voltage that tunes the VCO appears at the control-voltage output of the keyboard while a trigger appears at the trigger outputs. The trigger activates a function generator that produces a precisely preset time-varying voltage which in this case takes care of controlling the VCA to produce varying attack and decay times. The filter is stuck in there for harmonic control and it can be driven by control voltages from a variety of sources that we're not really concerned about.

The audio circuit is from the output of the VCO, through the VCF, through the VCA and finally to some sort of amplifier or recording device.

The part of this circuit that OZ replaces is *only* the keyboard and VCO and the control voltage path between the two. The rest of the patching configuration remains unchanged as shown in Fig. 9. The biggest difference is that by using OZ in place of the keyboard/VCO, you can now play full chords instead of the one-note-at-a-time restriction you previously had. Notice that the processed output can, if you wish, be

routed back to OZ's amplifier. You do have one drawback—OZ's output is basically a squarewave rather than the multiplicity of waveforms that you have available from most VCO's; but, with appropriate filtering (at the VCF), that is not really as much of a pain as you would first think.

Many of you will (I hope) be using OZ with the Gnome Micro-Synthesizer (See *Radio-Electronics*, November and December, 1975, and January, 1976, issues.) That's great; that really is what it's designed for. But, you're going to have to make some very light-weight changes to the Gnome before OZ and

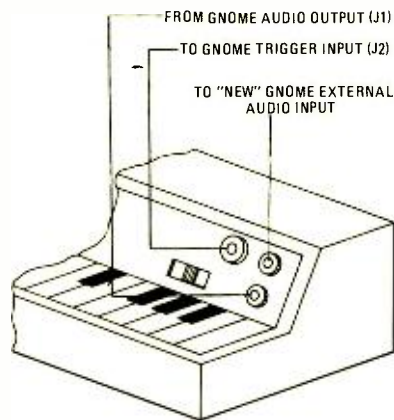

FIG. 11—CONNECTIONS TO GNOME.

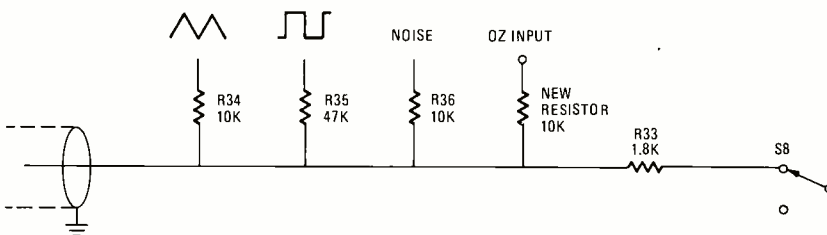

FIG. 10—THE GNOME'S AUDIO BUS, showing the added input and 10K resistor.

the Gnome are compatible. Specifically, you're going to have to add an external audio input to the Gnome audio bus.

Figure 10 shows the audio bus of the Gnome as it was illustrated in the series of articles, and you can see that we have added a new resistor that connects to this bus.

How this new input is made available to OZ is largely a matter of personal preference. In mine, the other end of the new resistor connects direct to a piece of co-ax which then drops out of the seam at the back of the Gnome case and terminates in a miniature phone plug. (In fact, the resistor is inside the Gnome as it was illustrated in the series of articles, and you can see that we have added a new resistor that connects to this bus.) A word of advice—**Do Not** connect both ends of the shield of the coax—there should be one and only one ground connection between OZ and the Gnome and that should be part of the line that runs between the Gnome's

output and OZ's input. Multiple grounds in different locations are like an insurance policy guaranteeing hum problems. Ground the shield of the coax mentioned above at the plug that *terminates* the line *only*.

From there, the interconnections are simplicity personified. Your "new" audio input cable connects to OZ's output, and the trigger jacks of both tie together. These connections are shown in Fig. 11.

Playing the Gnome/OZ combination is not very different from playing either one separately—though they are very definitely a synergistic pair. As a matter of fact, only one point need really be brought to your attention. It's this: leave the Gnome's VCA SUSTAIN switch in the sustain position. If you don't, the Gnome's percussion "mute" function will drive you bananas. **R-E**

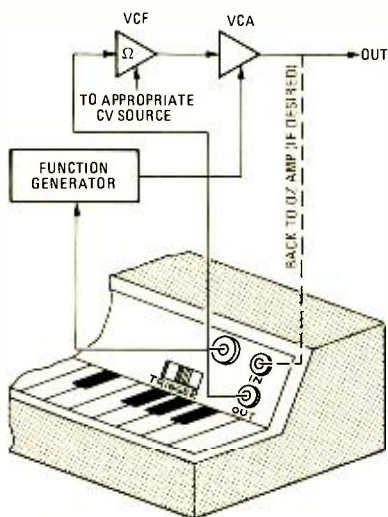

FIG. 9—OZ REPLACES KEYBOARD/VCO.

BUILD

Digital Clock For Your Car

Part II—Construction details on a useful automotive accessory that is rarely available as original equipment. A valuable aid for the trucker and road rally enthusiast that is simple and easy to build.

ROBERT C. ARP*

AN INTRODUCTION TO THIS USEFUL PROJECT appeared last month along with a detailed description of how the circuit works.

This month, the article concludes with the construction and calibration details, and foil patterns.

Construction

So that either type of display may be used with the clock, foil patterns for two double-sided display boards were prepared, as shown in Fig. 7. The two display boards are directly interchangeable with the main board. However, if incandescent displays are used, the copper trace on the main board that connects the emitter of Q3 to the -5 -volt bus must be cut. Then, a jumper wire should be connected from the emitter of Q3 to V_{DD} . The component layout for each display board is shown in Fig. 8.

Because the main board is separated from the display board, a variety of mounting schemes are possible: the display board may be dash mounted and connected to the remotely located main board with an edge connector, a display socket may be used to house the display (such as the Allied Electronics Cat. No. 658-1130) or the display board may be plugged into the main board, using Calectro Digi-Klips (Cat. No. J4-645).

* Product Engineer, National Semiconductor Corp.

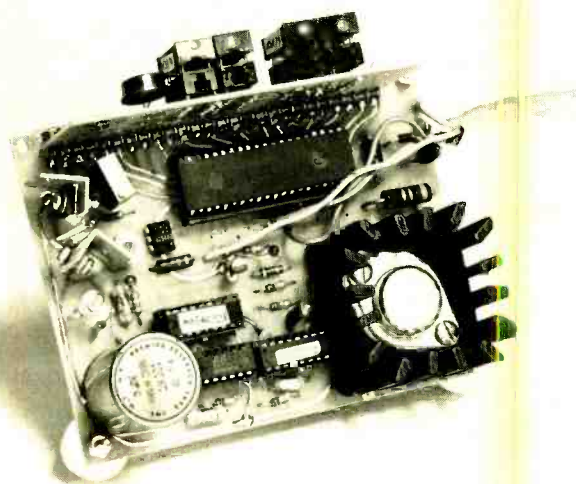
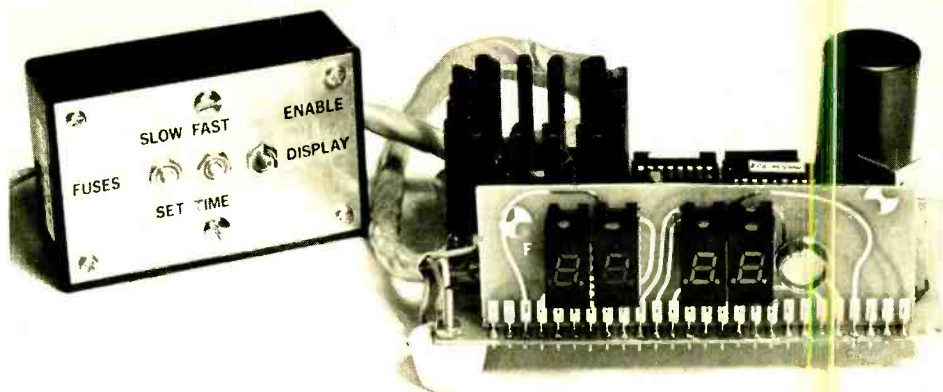

Digi-Klips are available at local Calectro dealers and are manufactured by GC Electronics, Div. of Hydrometals Inc., 400 South Wyman St., Rockford, IL 61101.

If you decide to use Digi-Klips, they are available in packages of 24 pins. Although 26 connections are required between the main board and the display board, a package of 24 pins will do the job if two connections are made with wire soldered to each board. The Digi-Klips allow a rigid perpendicular connection between the display board and the main board. They may, however, be placed in the main board with one pin higher than the other to provide a tilted display. If you elect to use the Digi-Klips, a drilling guide is provided in Fig. 9.

Caution: When mounting the Digi-Klips, do not remove them from their plastic carriers; insert the entire row into the holes in the board at the desired angle, and solder each Digi-Klip to its bottom edge-connector pad provided on the board. Then remove the plastic carrier with a small screwdriver and solder each Digi-Klip to its edge connector pad provided on top of the board.

The numeric displays should not be soldered directly to the display board. Mount Calectro Cat. No. J4-635 IC terminal sockets or Molex IC Terminals to the board, in strips of seven or eight, by soldering them both to the top and bottom in-line pads. The two tabs

to which the strips of terminals are connected should be closer to the center line of the in-line pads than should be the openings into which the display pins will be inserted. The tabs may be removed by bending them from side to side with long-nose pliers until they snap from the terminals. The displays are inserted into the terminals the same way they are inserted into an IC socket. IC sockets may be used on the main and display boards if the leads are long enough so the sockets can be soldered to all pads on the top of the main board and on the front of the display board that have copper traces running to them. In either case, the terminals or sockets that have copper traces running to them on the top and bottom of the board, must be soldered on both sides of the board.

If the incandescent displays are used, and if a viewing screen is used in front of them, the Radio-Shack Cat. No. 276-116 photoresistor must be used (see parts list). It must be mounted to the display board so that the black chimney is in direct, flush contact with the viewing screen. This will prevent light from the incandescent displays from reaching the photoresistor by reflection from the viewing screen.

If the LED displays are used, mount the photoresistor to the display board so that it stands as far away from the board as do the displays; the ambient light reaching the

photoresistor should be equal to the ambient light reaching the displays.

Display bezels may be purchased from Allied Electronics or Tracy Design Corp. The Allied No. 658-1240 bezel assembly has a red circularly polarized viewing screen and two mounting screws that can be used to mount it to the display board. The bezel may be separated from the display board with metal or fiber spacers. The No. 658-1240 bezel is actually made for five LED displays; the extra length is specified so that the bezel will accommodate the four displays plus a Clairex

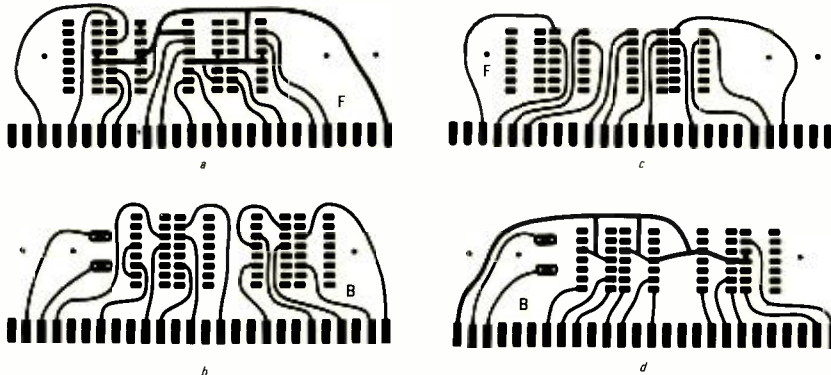

FIG. 7—DISPLAY BOARD foil-patterns shown half-size. a—front of incandescent display board; b—rear of same board; c—front of LED board; d—back of the LED board.

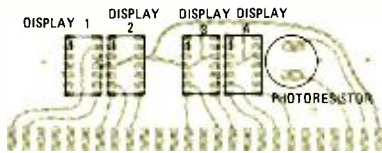

FIG. 8—DISPLAY BOARD COMPONENTS LAYOUT. Front view. Bezel mounting holes are centered by drawing a line across board, through the center of the displays. Inner bezel holes accommodate Allied 658-1240 bezel; outer ones the 658-1260. The photoresistor mounting holes are for Archer 276-116 or Clairex CL704L. Photoresistor solder pads are large enough to accommodate Clairex CLM54L if Allied 658-1260 bezel is used.

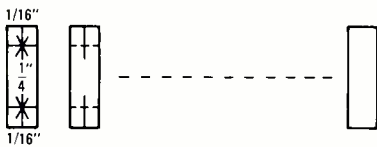

FIG. 9—GUIDE FOR DIGI-KLIPS

CL704L or a Radio-Shack No. 276-116 photoresistor. The fit is tight; width of the bezel is 3.2 inches.

If a greater bezel width can be tolerated, the Allied No. 658-1260, with a bezel width of 3.7 inches, may be used. This bezel will allow the use of a Clairex CL5M4L photoresistor. All three of the photoresistors mentioned above were used as intensity controls; the Clairex CL5M4L gives the best results.

The foil pattern for the double-sided main board is shown in Fig. 10 and the component layout diagram is shown in Fig. 11. Sockets should be mounted to the main board for the integrated circuits and a socket should be mounted for the opto-isolator/coupler in the same manner as they are installed on the display board. However, a decision must be reached about the MM5385 and MM74C221 installation before the terminals are mounted.

The main printed-circuit board layout demands that these two integrated circuits be mounted from the bottom of the printed-circuit board, or that their pins be bent back 180 degrees before they are mounted from the top of the board. This form of mounting is necessary because of the layout of the MM5385 pins.

There need be no fear of bending back the pins of an integrated circuit as long as the bending is done correctly, with the proper tool. Use a pair of tweezers with sharp, rather than blunt, blades to grasp each pin exactly

at the point it enters the package. The pins must be bent precisely at the package exit point and the edge of the tweezers must be held as close to the package as possible during the entire bending operation. This will prevent the pin from bending and breaking at the shoulder.

Bend the pins the full 180 degrees, one at a time, starting with a pin in the upper right hand corner of the IC and proceeding from pin-to-pin in a clockwise direction. You can practice on a bad IC, if one is at hand, or rejected IC's may be purchased at very little expense. Of course, a jig could be set up to bend all the pins on one side of an IC simultaneously.

After all the pins have been bent; check them for alignment before the IC is inserted into the terminals. The pins of all IC's should be carefully observed while the IC's are being inserted to make sure that all pins are actually inserted into the socket.

Next, without removing them from their plastic carriers, insert the first row of Digi-Klips from the top into the holes prepared in the main printed circuit board. Start at the end of the board where the heat sink is mounted. Look through both ends of the carrier and make sure that all center flats are touching the board. If they aren't, press them down with a very small screwdriver or other thin tool inserted into the appropriate end of

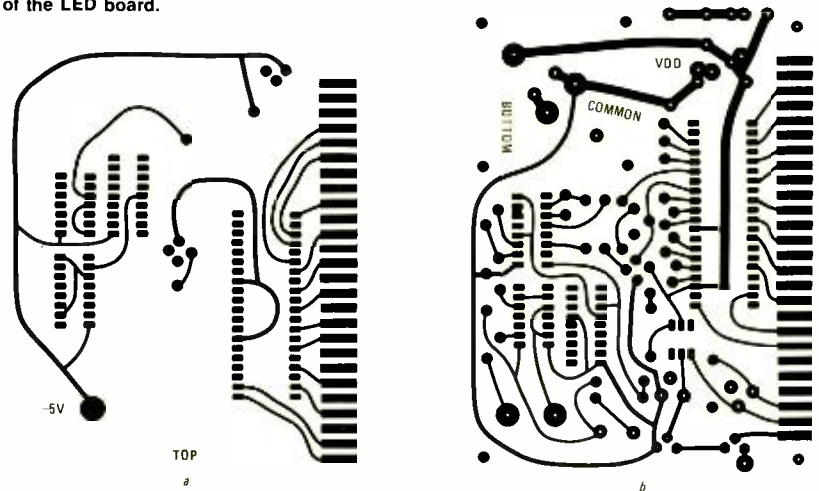

FIG. 10—THE MAIN BOARD foil-patterns shown half-size. a shows component side; b shows bottom. If board is made a little larger, corner holes may be moved out slightly; they are now positioned for minimum-sized board.

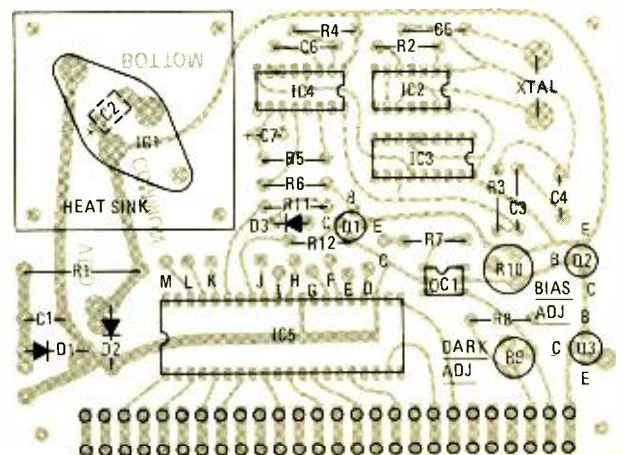

FIG. 11—COMPONENTS LAYOUT, MAIN CIRCUIT BOARD. Top view. Capacitor C2 mounts to bottom of board. Unless pins of MM5385 and 74C221 are bent back 180 degrees (see text) they must also be mounted to bottom of board.

the carrier.

Turn the board over, and, while holding the carrier in place, solder the Klips to the bottom. Remove the carrier with a screwdriver and solder the Klips to the top of the board. Do not allow solder to block the board opening in the center of the Digi-Klips.

Mount another row of Digi-Klips to the main printed circuit board in the same manner, then remove a Digi-Klip from a row in a fresh carrier. After mounting this Digi-Klip there will be an empty Digi-Klip hole at the end of the board on which Q2 and Q3 are to be mounted. (A connection must be made to this Digi-Klip hole, through an ammeter, from the display board power bus during calibration.)

Enough room on the main board has been provided for at least two types of crystals: the cylindrical and flat-type crystals up to 1-inch in diameter.

The heat developed by the LM320K-5 voltage regulator during normal operation of the clock may be dissipated in three ways:

1. Because the input to the LM320K-5 is the negative side of the battery, the voltage regulator may be mounted directly to the metal body of cars with negative ground electrical systems. Choose a level spot, make a good electrical connection, and use any silicone-type of heat sink compound between the regulator and the body of the car.
2. If the clock is to be housed in a metal cabinet, the voltage regulator may be mounted to the cabinet for heat dissipation as long as the total outer metallic surface area of the cabinet is equal to or greater than 42 square inches.
3. A heat sink equivalent to the Wakefield 680-1.25-A (see parts list) may be mounted to the printed circuit board and used to cool the regulator. The size of this heat sink is the minimum that can be used. All heat sink areas and sizes discussed assumes the use of a silicone heat-sink compound between the regulator and the heat sink. Separate the heat sink from the board about .05 inch. The heat sink must also be electrically insulated from the circuit board.

After mounting the LM320K-5 voltage regulator, a jumper must be soldered from the top of the main board at the LM320K-5 pin-2 hole to the bottom of the board at the same hole. This connects the -5-volt bus that runs along the top of the board to the output of the voltage regulator.

A heat sink must also be provided for Q2 and Q3. The Allied Electronics No. 957-2670, or a similar heat sink sold at Radio Shack stores as part of an assortment (Cat. No. 276-003), gives excellent results. The height of the heat sink is sufficient, so that three of the seven fins may be cut from the Radio Shack heat-sink. Use the three-fin sink for Q2 and the four-fin sink for Q3. Many similar heat sinks may be used; the thermal resistance should be about 24° centigrade-per-watt.

Switches for all the desired functions can be mounted in any convenient location. Wires from the power supply and switches must be soldered to the appropriate pads.

These pads are labeled A through M (see Fig. 11). Solder the wires necessary to provide the desired functions to their pads, and solder one in-line fuse from the accessory terminal of the ignition switch to pad "C" and an in-line fuse from the battery terminal of the ignition switch to pad "A". A wire must also connect from pad "B" to the negative terminal of the battery. It may be fastened to any part of the car chassis from which paint and/or rust have been removed.

The display board may be mounted to the main board by placing the main board on a sheet of 1/2-inch styrofoam, then, by pushing the display board into the Digi-Klips. The Digi-Klips should be centered on the connector pads of the display board.

If possible, the main board-display board assembly should be mounted in its permanent location before calibration. (This may not be feasible unless it is to be mounted in a metal cabinet.) Some suggestions for dash mounts have been: in a panel that has been cut to fit an original automotive clock, in seat-belt control cutouts provided in certain models, or in any blank area of the dash.

After calibration, remove the display board by prying it out of the Digi-Klips with a screwdriver so that the last Digi-Klip may be mounted to the main board. This Digi-Klip connects to the display board power bus.

Frequency calibration

The calibration instructions are the same for all supply voltage levels. However, with 6-volt systems the intensity of incandescent displays will be lower than that specified for 12-volt systems. Furthermore, the instructions for calibrating the display current are different for each type of display.

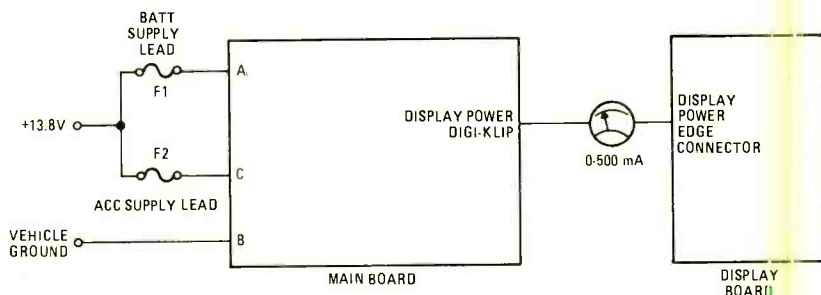

FIG. 12—CALIBRATION SETUP. Install both fuses before turning on power; set both pots to minimum resistance. If displays show an illegal readout after clock has been reset at initial power turn-on, disconnect power and troubleshoot the display board and displays for shorts or opens. Voltages shown are for a 12-volt system, engine running.

Before applying voltage to the clock, set both the DARK ADJUST potentiometer (R9) and the BIAS potentiometer (R10) for minimum resistance (full counterclockwise). Set R10 for minimum resistance at initial turn-on to prevent the flow of excessive display current that could destroy the displays.

Connect both the battery supply lead and the accessory supply lead to the positive side of the automotive voltage supply (see Fig. 12) with the engine running and the alternator delivering rated voltage to the electrical system. Insert a 0-500-mA meter between the display power Digi-Klip located at the extreme right on the main board and the display power edge connector located at the extreme right on the display board.

Connect the V_{DD} supply lead to the negative side of the automotive voltage supply. During the calibration, a cigarette lighter power plug may be used to interface the

clock to the vehicle's electrical system. If the clock is to be mounted in a truck, use the 12-volt supply rather than the 24-volt supply.

If the clock is to be mounted in a truck that does not have a 12-volt supply, change D1 to a 24-volt Zener diode. Also, lower the 24-volt supply to 12 or 15 volts using an LM340K-12 or LM340K-15 and appropriate heat sink. (If a much larger heat sink is used for the LM320K-5, a preregulator may not be necessary.)

Depress the SLOW SET or the FAST SET switch momentarily, to reset the power failure indicator, LED1, on the main circuit board should begin flashing at some rate between 36 and 180 flashes-per-minute. This is because the input to the clock will be between 30 and 150 Hz.

The 50 Hz input to the MM5385 may be adjusted precisely by connecting a digital counter with a resolution of 0.1 Hz between the collector of Q1 and V_{SS} . C4 may then be adjusted with a non-metallic tuning tool until the counter reads 50.0 Hz.

If a counter with at least this much accuracy cannot be used, the 50-Hz input to the clock can be adjusted by tuning C4 while observing the flashing rate of LED1. Because of the oscillator configuration, LED1 will flash only at rates between 36 and 180 per minute. This may be observed by rotating C4 counterclockwise 360 degrees while observing LED1. At some setting of C4, LED1 will be flashing at 180 flashes-per-minute. As the variable plate of C4 is turned counterclockwise past this setting, a point will be reached at which LED1 stops flashing at 180 flashes-per-minute, and, precisely at that point, begins to flash at a 60 flash-per-minute rate. At this point, the input to the MM5385

is 50 Hz. The accuracy of the adjustment may be checked by counting the number of flashes that occur within one minute as observed with a watch.

This method of adjusting the frequency of the oscillator is more accurate than that which can be obtained by using a digital counter with a resolution of 1 Hz, and is, at least, equivalent to the accuracy that can be obtained with a counter with a resolution of 0.1 Hz.

Although there are two points of adjustment that cause LED1 to flash at 60 flashes-per-minute, C4 should be adjusted counterclockwise through settings that cause LED1 to flash at 36 flashes-per-minute, 60 flashes-per-minute, 180 flashes-per-minute and set to the point at which it stops flashing at 180 flashes-per-minute. Whichever setting is used, C4 should be varied so that LED1 flashes at 180 flashes-per-minute just before

continued on page 86

Amplifier/Speaker Interface—a new concept

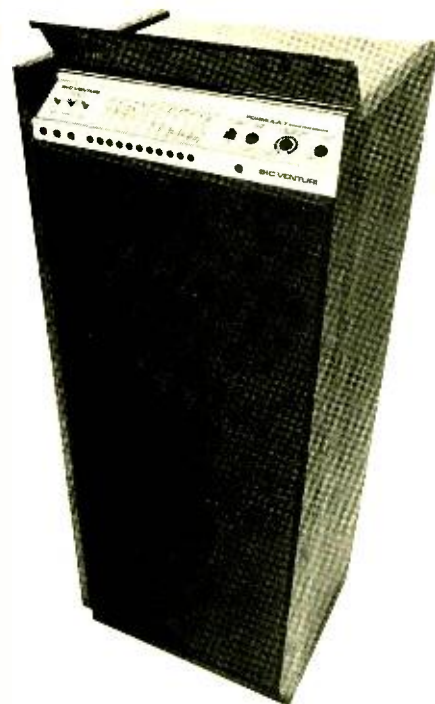

FIG. 1—FORMULA-7 MONITOR SERIES speaker system from British Industries Company.

Until now, matching the performance of an amplifier to a speaker has been a hit or miss affair. A new speaker system handles this problem in a unique way

LEN FELDMAN
CONTRIBUTING HI-FI EDITOR

THE STRINGENT RULES REGARDING AUDIO amplifier power ratings imposed nearly two years ago by the Federal Trade Commission has done much to standardize the way that hi-fi amplifier and receiver manufacturers advertise the power capabilities of their products. This standardization makes it easier to compare power specifications of different competing products. As most readers are aware, the law requires that amplifiers be rated on the basis of their ability to deliver continuous sinewave power into a specified resistive load. The amplifier does this over a specified band of audio frequencies at some specified value of total harmonic distortion.

That's all well and good as far as amplifiers are concerned, but in some ways it has made the problem of interfacing amplifiers with loudspeakers even more difficult than before. For one thing, we do not normally listen to continuous sinewaves and the complex waveforms produced by program sources may be handled quite differently by an amplifier compared to the way that it handles continuous sinewave signals.

Generally, amplifiers can deliver greater short-term power when fed with transient, musical signals than it can when dealing with continuous sinewave signals. Also, since music encompasses a wide dynamic-range of signal amplitudes, it is quite possible to listen to a system at what seems like reasonable loudness levels only to have sudden peaks (that may be greater in amplitude by as much as 10 dB, 20 dB or even more) drive that amplifier well into

clipping and audible distortion.

Conversely, a 50 watt-per-channel stereo amplifier, connected to a speaker system that is nominally rated to handle 50 watts, may well be driven to beyond its power handling capability by transient signal peaks. These transient peaks, though instantaneously well in excess of 50 watts, are *not* causing amplifier clipping because they are of such short duration. However, such power levels fed to the speaker, even intermittently, have been known to damage speakers or at least to drive their cones into non-linear operating regions with attendant distortion produced this time from the speakers themselves.

Finally, the so-called nominal power handling rating of the speaker may be based upon the capabilities of the more rugged woofer and not on the lower power-handling capacity of the mid-range or high-frequency drivers in the system. Inordinately high levels of high-frequency energy fed to such speaker systems (either because of super-audible amplifier oscillation, non-typical frequency distribution of musical energy commonly encountered with some forms of electronic music or from amplifier-generated harmonics due to inadvertent amplifier clipping) have been known to "blow" many an expensive mid-range driver or tweeter while the woofer remains intact.

A New Speaker System

A new speaker system, developed by British Industries Company, includes many innovative design features that are intended to alert the user of these

dangers and even to protect against their consequences. The B.I.C. Venturi Formula-7 Monitor Series speaker, shown in Fig. 1, is one of two new speakers that the company describes as a "speaker systems that think". It is our purpose here not to evaluate the sound reproducing qualities of the Formula 7 (preferences in speaker sound remain, as always, largely subjective), but rather to discuss the electronic and indicator circuits that have been incorporated in this unusual system.

The upper section of the speaker system contains a control and indicator panel that is shown in Fig. 2. On the front panel to the left of the speaker system is an LED indicator light and just above it, on the sloped section of the front panel, is an AMPLIFIER CLIPPING control. A special test record is supplied with the Formula 7. It contains a continuous signal made up of repeating bursts of 300 Hz, three cycles of which repeats every 100 milliseconds, as shown in Fig. 3. Thus, the duty cycle of this signal is 10%, not unlike the duty cycle of the peak signals in typical music.

In actual use, the listener plays this record through his amplifier and the Formula 7, increasing the volume setting until a distinct change is heard in the character of the pulse-like sound. This point corresponds to amplifier clipping (assuming the amplifier is the limiting factor of the combination). The user then rotates the AMPLIFIER CLIPPING control until the indicator light just flashes. Once the setting is made, the LED will light whenever the amplifier is driven to clipping levels by other musical program sources. The nice thing

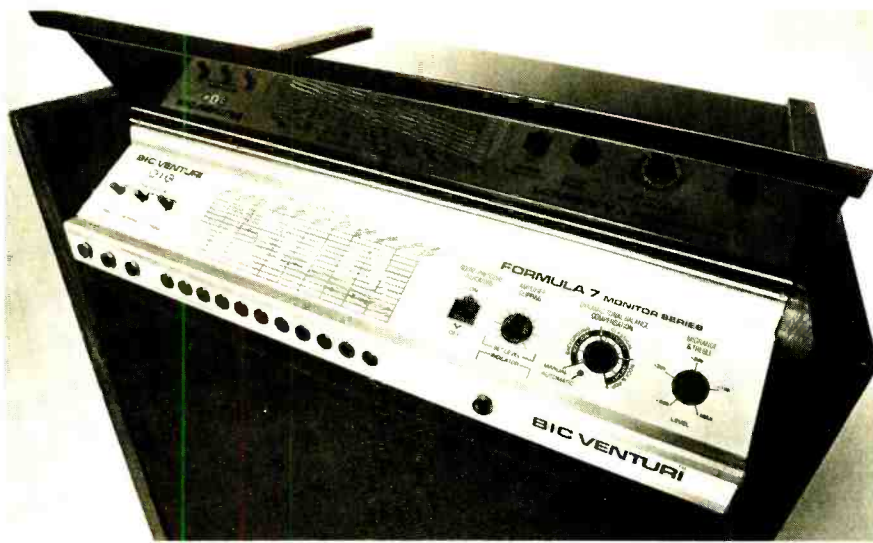

FIG. 2—CONTROL PANEL of the Formula-7 speaker system.

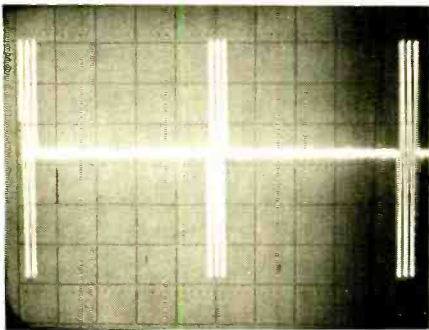

FIG. 3—TEST RECORD supplied with Formula-7 provides three cycles of 300-Hz signal every 100 milliseconds.

about this indicator is that it does not require that the user know or care what the dynamic (or music) power capability of the amplifier in question is in relation to its steady-state or continuous-power rating, since this is really of academic interest and not necessarily directly related to when the amplifier will begin to clip under actual listening conditions.

The clipping indicator feature, as well as two other major indicating and protecting features, will best be under-

stood by referring to the complete schematic diagram of the Formula 7, shown in Fig. 4. Audio signals delivered by the power amplifier to J1-1 and J1-2 are fed to the usual speaker drivers and crossover network components, with which we will deal shortly. In addition, the audio signal is rectified by diode D1 and applied to the positive input of IC3-a. The trigger point of LED9 is determined by picking off a portion of the fixed 5-volts DC from a built-in power supply via R23 and applying it to the negative input of IC3-a. Thus, the trigger point of LED9 can be adjusted by means of R23 (the front panel AMPLIFIER CLIPPING control previously referred to) over a wide range corresponding to amplifier outputs up to around 125 watt-per-channel.

Now, suppose the user owns an amplifier that exceeds the safe power-handling capability of the speaker system. In that case, auditioning of the test record might result in speaker distortion or damage well before the amplifier begins to clip. To prevent overdriving of the speakers in this manner, additional indicator and protection devices have been incorporated.

Referring now to the portion of Fig. 4 that shows the four drivers you will note that there are three circuit breakers (CB1, CB2 and CB3) wired in series

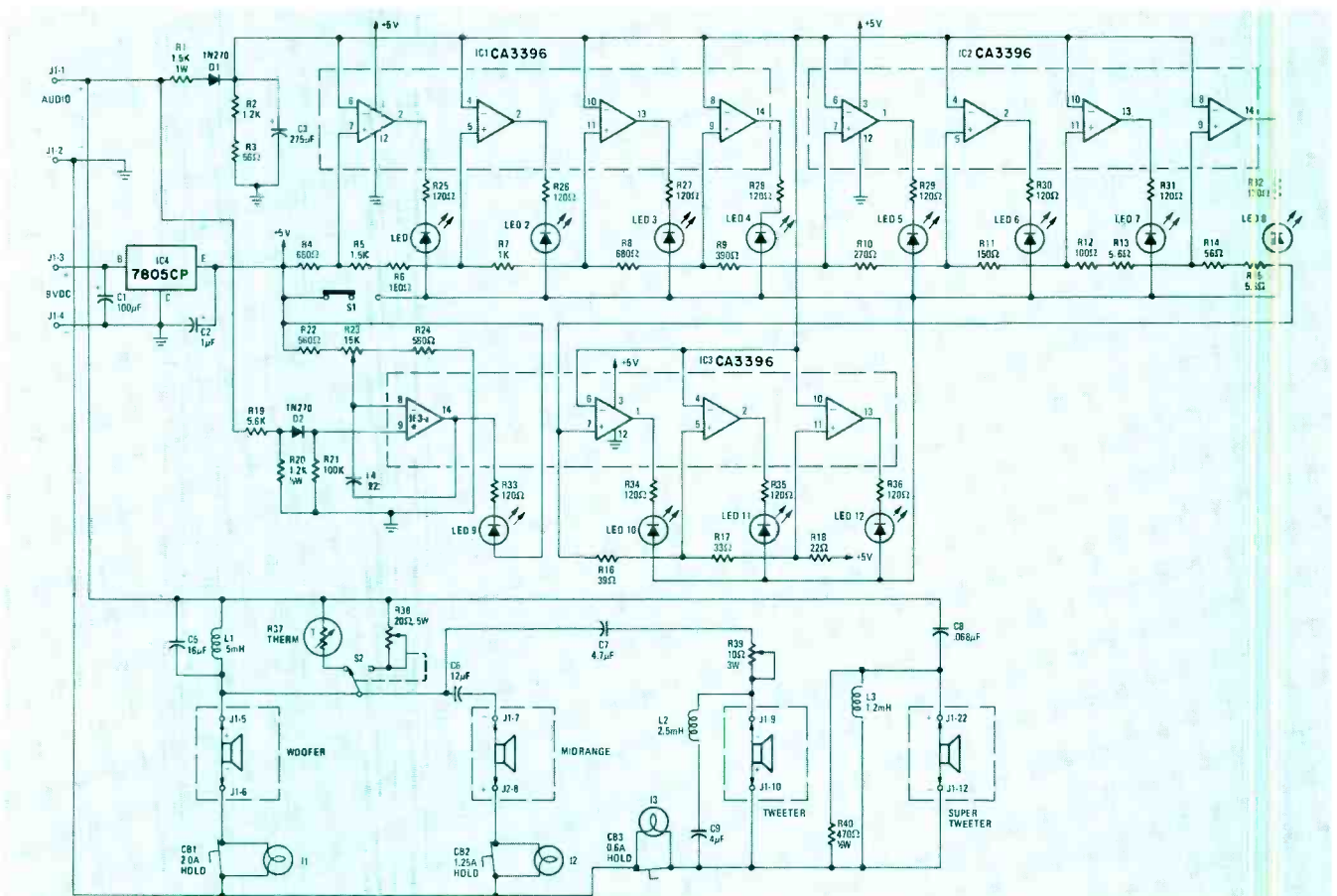

FIG. 4—INTERFACE AND CROSSOVER circuitry of the Formula-7 speaker system.

with each driver. Each circuit breaker is rated at an appropriate value from 2.0 amperes for CB1 to 0.6 amperes for CB3. When the current exceeds the circuit-breaker rating, the appropriate circuit breaker opens and an indicator light wired across that circuit-breaker flashes in accordance to the signal current that then flows through it.

The three circuit breakers are located on the sloped portion of the front panel and are manually resettable. Dividing up this indicating system instead of having a single circuit-breaker permits the user to determine *which* driver elements of the unit are being overdriven and even warns of trouble in the event of super-audible high-frequency oscillation that, while inaudible, might easily destroy the high frequency driver elements.

One other aspect of the Formula 7 is worth mentioning before we leave the speaker-driver section of the schematic. Thermistor R37 is the key component in what B.I.C. calls its "dynamic tonal compensation" system. When front-panel mounted potentiometer R38 (which varies the signal level fed to midrange and tweeter) is rotated fully counterclockwise, switch S2 is thrown to the position shown in Fig. 4. The value of thermistor R37 varies in accordance with the average current flowing through it. R37 is chosen so that when loud levels are reproduced, its resistance is very low (due to the heating effect of the thermistor) while at lower listening levels, its resistance increases and reduces the mid- and upper-mid frequency sound levels. This amounts to the same thing as boosting (relatively) the bass response and is designed to compensate for the well known Fletcher-Munson loudness effect in human hearing. This effect is often compensated for by the so-called loudness controls on amplifiers and receivers. The advantage in this approach is that the resultant response can be directly related to actual sound-pressure levels and not to arbitrary settings of a master volume control that cannot take into account such variables as program source signal levels, speaker efficiency or amplifier gain.

SPL indication

The audio signal from the amplifier is rectified and filtered by capacitor C3 and diode D1. (See Fig. 4.) This varying DC voltage is applied to the negative inputs of eleven comparator circuits (four in IC1, four in IC2 and the three remaining in IC3). The positive inputs of these comparators are supplied with progressively lower and lower DC voltages that are determined by the string of series resistors R4 through R18. Thus, when the lowest-level signals are applied, LED12 will light, while increasingly stronger input signals will trigger

LED11, LED10 and so forth up to LED1 which flashes when the greatest audio signal levels are applied to the system.

The row of LED's on the front panel are calibrated in approximately 4-dB increments all the way from 75-dB SPL (Sound Pressure Level) to 117-dB SPL. A chart inscribed right on the system's front panel (see Fig. 5) permits the user to translate the LED indications into actual sound pressure levels, measured at specific distances on-axis from the speaker system. Alternatively, the user can read the average sound pressure level attained in listening rooms varying in cubic volume from 1000 cubic feet (a

several others inscribed over the various LED's below the chart. Observing the flashing lights while listening to music for extended periods may appeal to some hi-fi fans while others may wish to just listen and not look, having established desired levels. For this reason, the Formula 7 has a switch (SW2 in the schematic diagram) that permits you to turn off the sound pressure level indicators at will.

Much of what B.I.C. has built into the Formula 7 is fairly simple in terms of circuit complexity, and the information it provides could be obtained if you owned a good SPL meter and an accurate audio power meter. But few

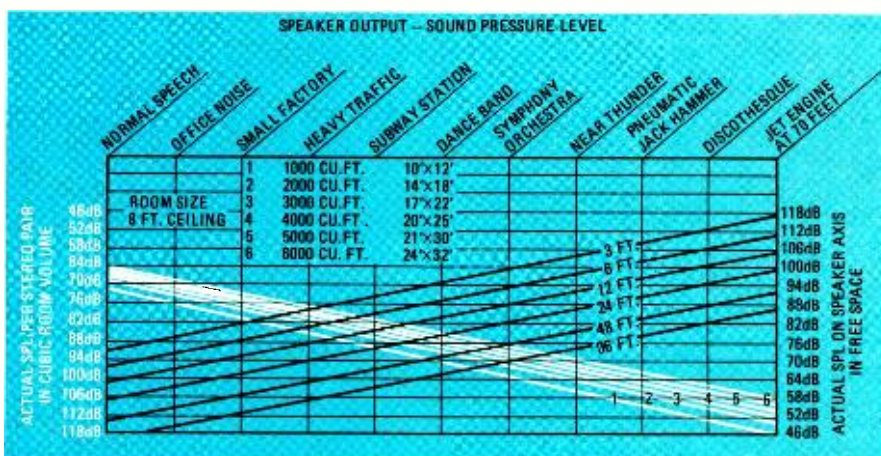

FIG. 5—GRAPH ON FRONT-PANEL enables user to translate power readings into actual sound pressure levels.

room having floor dimensions of around 10 x 12 feet) to 6000 cubic feet (approximately 24 x 32 feet).

The idea of using LED indicators to show audio power levels is, of course, not new and is currently being used on a variety of higher-powered high-priced audio amplifiers available in the hi-fi market. The unique thing about incorporating such indicators on the speaker system itself is that, for the first time, the indicator readings are directly translatable to actual sound pressure levels and not just to wattage levels delivered by an audio amplifier into a fixed resistive load. The manufacturer (in this case B.I.C.), having control of the efficiency of the speaker system and being able to measure actual sound output (in dB SPL) for a given signal voltage input to the loudspeaker system, was able to prepare the chart shown in Fig. 5 so that users can relate the information supplied directly into perceived loudness levels.

From a practical point of view, the system enables the user to balance stereo channels in terms of actual audibility and also permits listeners to judge how loud various programs they listen to really are, as compared with familiar reference levels such as symphony orchestra, dance band, discotheque and

serious audio enthusiasts want to become audio technicians as well. The incorporation of these features in this speaker, as well as in a lower-priced Formula 5 system announced by the company (that one lacks the SPL indicators but has the amplifier clipping indicator as well as the speaker protection indicators and dynamic tonal compensation feature) will, at least, provide a certain amount of peace of mind to users who tend to push their systems to the limit. **R-E**

Higher hi-fi recording group goes back to direct-on-disc

A Canadian record company, Nimbus 9 Productions Ltd., has abandoned the tape-recording stage of disc production. The new direct-on-disc albums, bearing the Umbrella trademark, will be sold in the United States by Audio-Technica, the phono cartridge firm.

According to Jon Kelly, general manager of Audio-Technica, bypassing the tape recording stage eliminates problems of distortion, limited dynamic range, and of course, tape noise. Because engineers mix and record the studio performances direct onto a master disc, Kelly points out: "Musicians and engineers must display a high degree of professionalism. There is no room for error."

Records were expected to be available early this winter at \$12.95 retail.

Radio-Electronics

Tests

Soundcraftsmen PE2217 Equalizer



LEN FELDMAN
CONTRIBUTING HI-FI EDITOR

FOR MANUFACTURER'S LITERATURE,
CIRCLE 85 ON FREE INFORMATION CARD

LAST MONTH WE EXAMINED A RELATIVELY INEXPENSIVE five-band add-on graphic equalizer supplied in kit-form by Heath. The add-on type of graphic equalizer lends itself particularly well to application in hi-fi systems that have already been assembled and which may contain an all-in-one receiver, or an integrated amplifier, or even a separate preamplifier and basic power amplifier. The audio enthusiast who chooses to use completely separate components may find it a bit cumbersome to add yet a fourth major component such as an equalizer to what is already a growing number of individual components. After all, one's shelf or cabinet is only so large. Accordingly, Soundcraftsmen decided that it would be a good idea to combine one of their better graphic equalizer circuits with a highly flexible and well designed preamplifier/control unit, and that is just what their PE2217 adds up to. The front panel, shown in Fig. 1, looks very much like the front panel of that company's model RP2212 equalizer that sells for around \$370.00 alone. So, if you are in the market for a preamp and a graphic equalizer you might say that the preamp section of the PE2217 only adds around \$160.00 or so above the cost of a 10-band graphic equalizer. Viewed from that point, that's quite a bargain, especially when you consider what the preamp section of the PE2217 can do all by itself.

Preamp related controls are located along the bottom of the front panel and include a POWER on/off pushbutton with an indicator light just above it, a master VOLUME control, a BALANCE control, two stereo HEADPHONE jacks (one disables the line outputs at the rear when a plug is inserted, the other does not) and a TAPE 2 input and output jack pair that provides front-panel connection of a second tape deck and are wired in parallel with similarly labeled phono-tip jacks at the rear. The rightmost bank of pushbuttons take care

of program source selection. Six more push-buttons at the center handle the Tape 1 and Tape 2 monitor circuits, as well as the dubbing options from Tape 1 to Tape 2 or vice versa. The two remaining buttons in this bank permit instant comparison of equalized or unequalized sound and also enable you to apply pre-equalized signals to your tape deck inputs—a very handy feature for adventurous recordists, and one generally not found on preamps or even on separate equalizers.

The upper section of the panel resembles the front of the previously referred to RP2212 equalizer. Two identically calibrated groups of ten slide controls handle octave-by-octave response adjustments for left and right stereo channels. Between these banks of slide controls are two additional gain controls, flanked by upper and lower LED indicator lights for each channel. These controls are active only when the equalization circuits are selected and are used to re-establish identical overall sound levels with those of the unequalized signals, when comparisons are to be made. This is necessary because even if a few of the slide controls are in the "boost" region, overall apparent reproduced levels will be louder than would be the case if all sliders were set to their mid-positions, where the response of the system is flat. The indicator lights flash when program material is channeled through the equalizer, and equal flashing of upper and lower lights indicates correct setting of the gain adjust controls.

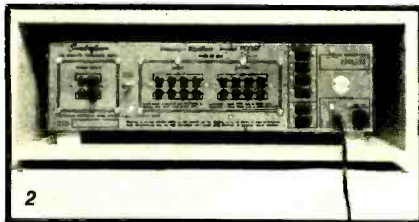

The rear panel of the PE2217 is shown in Fig. 2. The twin pairs of low-level phono inputs at the left are isolated from the high level inputs and tape output at center, a layout detail that permits the most direct and shortest wiring from these inputs to the critical, low-level phono preamp section visible at the rear right of the chassis in Fig. 3. A

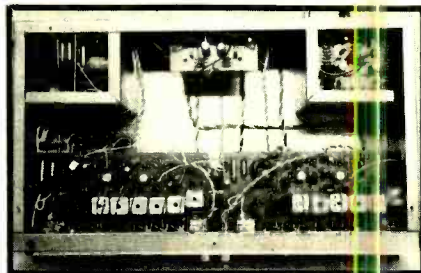

chassis ground terminal is located near the phono input jacks, and, at the extreme right of the rear panel, there are six convenience AC outlets (four switched, two unswitched) for connection of other components. A line fuseholder is located at the lower right, adjacent to the power cord.

Circuit layout

In examining the layout and construction of the PE2217 (Fig. 3), we noted that two identical circuit boards are used for the two channels of equalization. LC filters, using discrete inductances, are employed for each octave filter circuit and, if like us, you can only count six "cans" on each board, rest assured that there are four more per board, resting securely on the surface of the PC boards since they are the ones that handle the lower octaves and are therefore too large in size for standard encapsulation. The power supply at the left-rear is in its own fully shielded compartment, as is the phono preamp section at the right rear. Separate power-supply voltages are provided for the preamplifier circuits and the equalizer circuits in this design. All switches (discussed by the equalizer boards) have gold plated contacts for lowest possible resistance, and the PC boards themselves are of military-grade G-10 glass-epoxy construction. In examining the circuit boards closely we noted the use of several low-noise carbon-film resistors in critical low-level circuits.

An idea of the flexibility of this combination unit can be gained by examining the

MANUFACTURER'S SPECIFICATIONS:

Frequency Response: High Level Inputs: 5 Hz to 100 kHz, ± 0.25 dB; Phono Inputs: RIAA ± 0.5 dB. **Harmonic Distortion:** 0.05% at 1 volt. **Signal-to-Noise:** High Level Inputs: 100 dB; Phono Inputs: 84 dB (ref. 10-mV input); Equalizer Section: 90 dB below 1 volt **Overall Maximum Gain:** High Level Inputs: 21 dB; Phono Inputs: 63 dB. **Phono Overload Level:** 105 mV. **Output Impedance:** 600 ohms. **Octave Control Range:** ± 12 dB minimum. **Octave Centers:** 30 Hz, 60 Hz, 120 Hz, 240 Hz, 480 Hz, 960 Hz, 1920 Hz, 3840 Hz, 7680 Hz, 15,360 Hz. **Dimensions:** (In supplied wood cabinet): 20 wide by 7 $\frac{1}{4}$ high by 11 $\frac{1}{4}$ inches deep. **Panel Dimensions:** 5 $\frac{1}{4}$ high by 18 inches wide. Also available for rack-mounting, less cabinet at same price. **Suggested Retail Price:** \$529.50 (cabinet or rack panel mount).

signal flow. The master VOLUME control is located just ahead of the line amplifier so that best signal-to-noise ratios are maintained. The equalizer section contains those level-matching gain controls that were mentioned earlier and insure against possible overload or distortion within the equalizer section itself. The position of the equalizer section and the switching arrangement permits the user to equalize both the signals at the tape-output jacks and at the line-output jacks, and either of these outputs can be fed with an unequalized signal while the other delivers an equalized signal. Tape dubbing can be accomplished even while listening to another program source such as phono or tuner.

Laboratory measurements

Our measurements of the PE2217 necessarily consisted of two separate groups. First, we checked the action of the equalizer controls themselves. We did this by "plotting" the response obtained at the maximum boost and maximum-cut position of each of the ten octave-controls of a single channel and storing the combined results on the storage-scope of our spectrum analyzer. The spectrum analyzer had been swept from 20 Hz to 20 kHz for each of the twenty-one (including flat response) response curves. The results are shown in the photo of Fig. 4. Maximum boost range to maximum-cut of

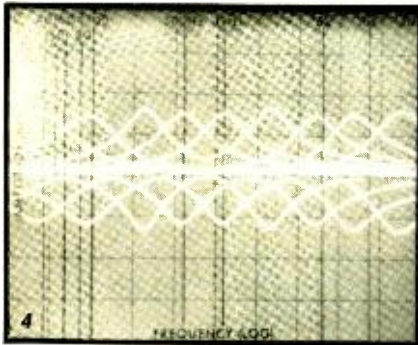

each control measured approximately 28 dB, or ± 14 dB from the mid-position of each slide control. Peaks are quite evenly spaced which, in this logarithmically plotted sweep means that they were exactly an octave apart, as claimed.

To check the interaction of adjacent

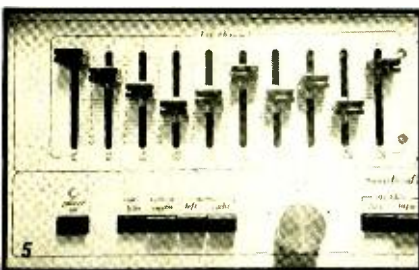

controls, we set up an arbitrary response curve that might typically be required in a less-than-perfect component/acoustic situation. The ten control-knobs were set as shown in the close-up photo of Fig. 5 and a response curve was plotted for these settings. The response obtained is shown in Fig. 6. It corresponds quite closely with the settings of the ten knobs, with the exception of the region of the eighth-octave control that had called for a slight rise in frequency and was

TABLE I		
RADIO-ELECTRONICS PRODUCT TEST REPORT		
Manufacturer: Soundcraftsmen	Model: PE2217	
PREAMPLIFIER PERFORMANCE MEASUREMENTS		
INPUT AND OUTPUT REFERENCE LEVELS	R-E Measurement	R-E Evaluation
High level input levels (V)	1.0	
Low (phono) input levels (mV)	10.0	
DISTORTION MEASUREMENTS		
THD at reference input level (%)	0.04	Very good
Input clipping level (V)	3.5	Excellent
Output clipping level (V)	5.0	Good
PHONO PREAMPLIFIER MEASUREMENTS		
Frequency response (RIAA \pm ___ dB)	0.2	Excellent
Maximum input before overload (mV)	100	Good
Hum/noise referred to full output (dB) (10 mV input)	84	Very Good
HIGH-LEVEL INPUT MEASUREMENTS		
Frequency response (Hz-kHz, \pm ___ dB)	10-50, 0.5	Excellent
Hum/noise referred to full output (dB)	98	Excellent
Residual hum/noise (min. volume) (dB)	98	Very good
TONAL COMPENSATION MEASUREMENTS		
Action of bass and treble controls		Not applicable
Action of secondary tone controls	See Fig. 5	Excellent
Action of low frequency filter(s)		Not applicable
Action of high frequency filter(s)		Not applicable
COMPONENT MATCHING MEASUREMENTS		
Input sensitivity, phono 1/phono 2 (mV)	1.1/1.1	
Input sensitivity, auxiliary input(s) (mV)	100	
Input sensitivity, tape input(s) (mV)	100	
Output level, headphone jack(s) (V or mW)	1.0V (Hi Z only)	
EVALUATION OF CONTROLS, CONSTRUCTION AND DESIGN		
Adequacy of program source and monitor switching		Superb
Adequacy of input facilities		Very good
Arrangement of controls (panel layout)		Excellent
Action of controls and switches		Fair (see text)
Design and construction		Excellent
Ease of servicing		Good
OVERALL PREAMPLIFIER PERFORMANCE RATING		Very good

offset by the dip position of the ninth-octave adjacent control and the flat setting of the adjacent seventh-octave slider. The likelihood of ever needing such a narrow peak in

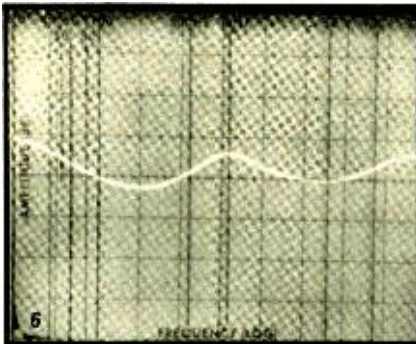

the response of a real system is very slim.

Measurements related strictly to preamplifier performance of the PE2217 are listed in Table I and generally ranged from good to excellent. The sole exception was the action of the slide controls themselves, and our criticism of these will be found in our summary comments following our overall product analysis in Table II.

Use and listening tests

In general, the PE2217 handles well. Program-selection pushbuttons and the six centrally located pushbuttons that handle the tape functions and equalization selection are all interlocked within each grouping to prevent accidental pushing of two buttons at

once. The preamplifier's output was at all times adequate for driving even the most insensitive (low gain) of basic power amplifiers.

We found that it is extremely important to be guided by those flashing gain-adjust test lights when the equalizer is "in-circuit", for to ignore their warning is to invite higher levels of overload and distortion. While it is possible to disable the indicator lights at the push of a button (the presumption being that you will tire of watching them flash after proper levels have been set up) we would suggest that they be allowed to do their job at all times, or at least when you switch from one program source to another.

While much of the flexibility of the PE2217 is related to tape recording activities, we feel that even the audio enthusiasts who does not own a tape deck but wants to own a good preamp and an effective graphic equalizer will find that Soundcraftsmen's PE2217 merits consideration on both counts.

Accessories

Although, in theory, one setting of the equalizer controls should suffice for all times (as far as one's system and room acoustics are concerned), there are times when particular program sources may call for different settings of the twenty octave controls. After all, recording engineers apply "equalization" at the studio, too, and you may not always agree with their ideas of tonal balance. For this reason, and because some over-enthusiastic visiting sound-buff friend may not be able to resist the temptation to try his or her

TABLE II

RADIO-ELECTRONICS PRODUCT TEST REPORT

Manufacturer: Soundcraftsmen

Model: PE-2217

OVERALL PRODUCT ANALYSIS

Retail price	\$529.50
Price category	High
Price/performance ratio	Good
Styling and appearance	Excellent
Sound quality	Excellent
Mechanical performance	Good

Comments: Combining the functions of a ten-band graphic equalizer and a preamplifier/control unit in a single chassis makes a lot of sense to us, particularly since the increased popularity of graphic equalization, or "room voicing", is primarily one that has arisen from audio enthusiasts who choose to assemble their systems from separate components. Octave-by-octave tone adjustment is, in our opinion, the minimum segmentation needed to do a precise compensating job and, while not as precise as third-octave equalization, it is more effective than what can be done with the lower-cost five-segment units that are available. Although Soundcraftsmen suggests that a good job of equalization of one's system can be done using their supplied test record and one's own ears, we found that a much better job can be done using a sound-level meter—even if it has to be one of the very inexpensive ones that are now available. The ear is too easily deceived, even when pink noise bands are used as the test signal.

As for the preamplifier/control sections of the PE2217, they measured right up there with the best of the separate preamps around. Audible distortion is not likely to be a problem, unless generated by other components in your system, and the flexibility of the switching facilities (especially those related to tape recording, including the pre-equalization possibilities) make the unit a self-contained "patch panel" that will be appreciated by those who own a pair of tape decks and are constantly finding it necessary to plug and unplug cables to achieve required results.

We wish that Soundcraftsmen had supplied detents, or click-stops for the flat settings of each octave control, and that the overload characteristics of the unit (when in the equalization mode) were not so critically dependent upon correct "zero gain" adjustment of those gain controls, but when care is taken, the preamp behaves like a good preamp should, and the equalizer does its expected job much as a separate one would.

own preferred settings. Soundcraftsmen supplies six reference-charts that enable you to permanently record your preferred settings for different program sources and listening situations. The charts may be cut out, so that when you want to return to the settings called for on a given chart, you simply slip it under the ten octave-controls (spacing on the chart between controls is to scale) and position the levers until they intersect the upper edge of the cut-out chart.

Another accessory supplied with the PE2217 is a special test recording that contains octave-band pink-noise signals that can be used to help you "voice" your entire system, including your listening room. Instructions are offered for both those who own no test equipment and for those who own a sound-level meter. In the ears-only method, a mid-band pink noise signal is reproduced over one channel, while individual octave-bands corresponding to the ten controls on the other channel are played for level comparison. As noted in our summary comments, we did not find this by-ear method to be particularly accurate and preferred using an inexpensive sound level meter with which we were able to do a much better job in our listening room. **R-E**

Bigston BSD-300 Cassette Deck

WHEN FRONT-LOADING CASSETTE DECKS WERE first introduced for home high-fidelity systems, they were fairly expensive gadgets selling for \$300.00 or more if they included Dolby noise reduction circuitry. The public's acceptance of the front-loading cassette deck configuration has prompted a great number of manufacturers to produce lower-cost decks that offer the same advantages of "stackability" with other high-fidelity components. One of the lowest priced of these that we have had an opportunity to test and evaluate is the Bigston *BSD-300*. Bigston Corporation is perhaps not too well known here for its own products but, according to information we obtained from the company's U.S. headquarters, that company has been and continues to be a large supplier of "private label" or custom manufactured tape recording products for retail chains.

As for the *BSD-300* itself, the photo of Fig. 1 shows its front panel layout. Cassettes are inserted, tape forward, into the sloped compartment at the left. This compartment is illuminated for better visibility inside when



FOR MANUFACTURER'S LITERATURE, CIRCLE 86 ON FREE INFORMATION CARD

power is applied by means of the pushbutton switch at the lower left. A three-digit counter with the usual reset button is also located in the forward part of the cassette compartment. Seven identical metal toggle-levers just below the cassette compartment take care of the EJECT, RECORD, REWIND REVIEW, PLAY, FAST FORWARD CUE, STOP and PAUSE transport functions.

This is one of the few decks we know of that can be placed in the record mode by

pressing the single RECORD button. Most others require simultaneous hold-down of both the RECORD and PLAY buttons. The dual-button arrangement is normally a precautionary measure to prevent accidentally erasing a precious recording and is a carry-over from the early days of cassette decks. We have often thought that the bother of having to carefully depress two buttons at once to get into the record mode more than offsets the safety feature and apparently Bigston thought so too.

The REWIND REVIEW and FAST FORWARD/CUE levers serve a double purpose. Used alone, they perform the normal fast rewind or fast forward functions. Used when the PLAY button is depressed, they permit fast wind in either direction (so long as the button is held down manually) while some sound is heard through your system, thereby enabling rapid location of a specific point in a given cassette tape. The only other units we know of that have this capability (aside from low-fi portable dictating cassette decks) are those offered by Kenwood and sell for quite a bit more than this Bigston model.

The right section of the panel is equipped with a pair of small VU level meters calibrated from -20 dB to +5 dB and with a Dolby level mark. A RECORD indicator lamp is located between the meters. Below, are three buttons that select tape bias, equalization and Dolby circuitry. The bias and EQ buttons work independently, thereby afford-

MANUFACTURER'S PUBLISHED SPECIFICATIONS:

Frequency Response: Standard Tape: 30 Hz to 13,000 Hz; CrO₂ Tape: 30 Hz to 15,000 Hz. **Wow-And-Flutter:** 0.08% WRMS. **S/N Ratio:** Without Dolby: 48 dB; With Dolby: 56 dB. **Output Level:** Line: 0.58 volts; Phones: 0.3 mV/8 ohms. **Power Consumption:** Approx. 10 watts. **Dimensions:** 14⁷/₁₆ wide × 5¹/₂ high × 10¹¹/₁₆ inches deep. **Weight:** 11³/₄ lbs. **Suggested Retail Price:** \$169.95

Engineers design electronic circuits —so can you!

**Only CREI offers you a choice
of 18 home study programs
in electronics with circuit design,
plus special arrangements
for engineering degrees**

Circuit design is perhaps the one qualification that distinguishes advanced technical personnel and engineers from the average electronics technician.

If you can design electronic circuits, you can more readily understand the circuitry of all types of electronic equipment. Thus you can more easily handle the repair and maintenance of such equipment, as well as assist in the development of new electronic systems.

The ability to design electronic circuits to solve practical engineering problems is one of the most valuable skills you can possess. Those with this ability are sought after and command positions of far greater responsibility, prestige and pay than the average technician.

If you are going to have a worthwhile career in the field of electronics, the ability to design circuits is a skill you will want to acquire.

Circuit design in all CREI programs

CREI covers circuit design in its home study programs in electronics. This is one of the factors that makes CREI training different from most other home study schools. CREI programs, of course, are college level—the same level of training you will find in any college or university offering programs in electronic engineering technology.

CREI training, however, is designed for home study. The programs give you effective, step-by-step training to help you move up in your career in electronics by using your spare time for technical self improvement.

Unique Design Lab

CREI gives you both theory and practical experience in circuit design with its Electronic Design Laboratory Program. The professional equipment included in this program allows you to construct, test out and correct the circuits you design until you have an effective circuit.

This Lab Program helps you understand advanced electronics. It also gives you practical experience in many other important areas of electronics, as in prototype construction, breadboarding, test and measurement procedures, circuit operation and behavior, characteristics of electronic components and how to apply integrated circuits.

Career Training at Home

Only CREI offers this unique Lab Program. It is a complete college lab and, we believe, better than you will find in most colleges. The "Lab" is one of the factors that makes CREI training interesting and effective. And the professional equipment in this program becomes yours to keep and use throughout your professional career after you complete the training.

Engineering Degree

CREI offers you special arrangements for earning engineering degrees at certain colleges and universities as part of your home study training program. An important advantage in these arrangements is that you can continue your full time job while "going to college" with CREI. This also means you can apply your CREI training in your work and get practical experience to qualify for career advancement.

Wide Program Choice

CREI gives you a choice of specialization in 14 areas of electronics. You can select exactly the area of electronics best for your career field. You can specialize in such areas as computer electronics, communications engineering, microwave, CATV, television (broadcast) engineering and many other areas of modern electronics.

FREE Book

In the brief space here, there isn't room to give you all of the facts about CREI college-level, home study programs in electronics. So we invite you to send for our free catalog (if you are qualified to take a CREI program). The catalog has over 80, fully illustrated pages describing your opportunities in advanced electronics and the details of CREI home study programs.

Qualifications

You may be eligible to take a CREI college-level program in electronics if you are a high school graduate (or the true equivalent) and have previous training or experience in electronics. Program arrangements are available depending upon whether you have extensive or minimum experience in electronics.

Send for this **FREE** Book describing your opportunities and CREI college-level programs in electronics

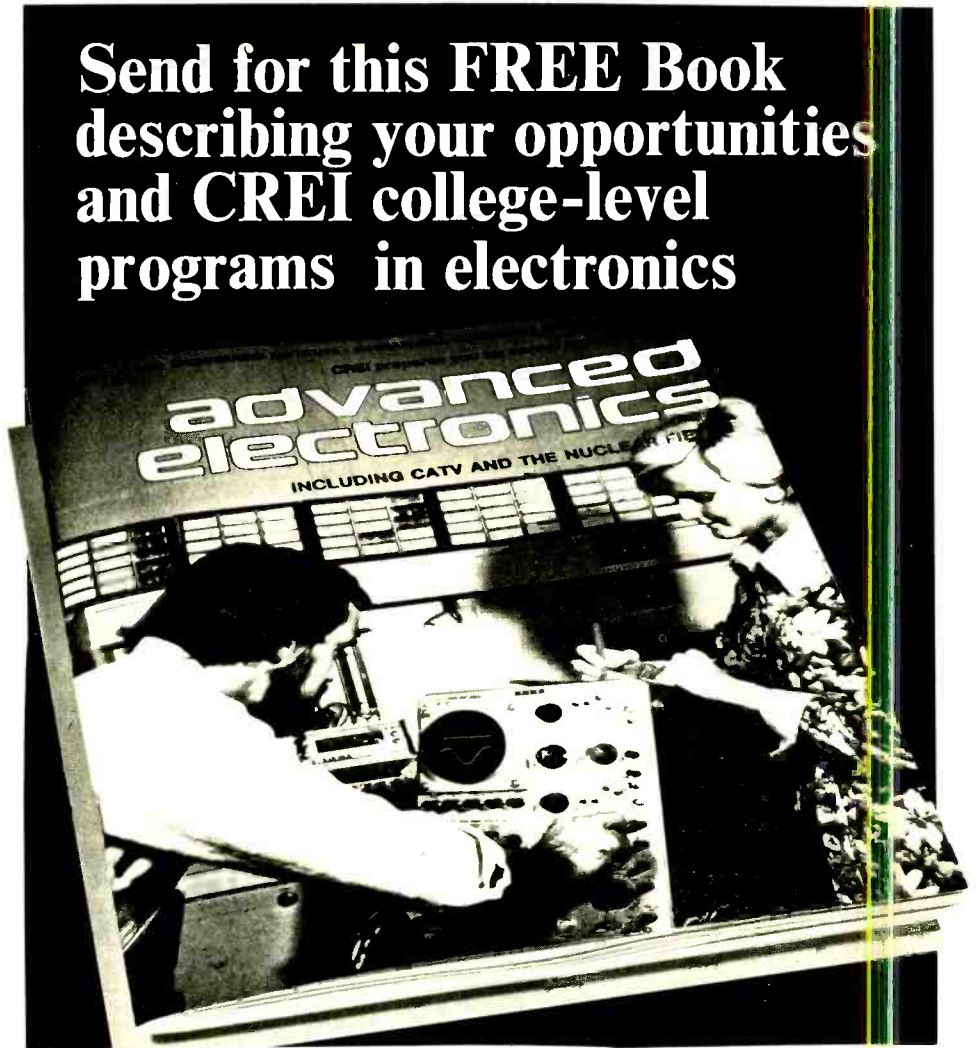

Mail card or write describing qualifications to

CREI **CAPITOL
RADIO
ENGINEERING
INSTITUTE**

McGraw-Hill Continuing Education Center
3939 Wisconsin Avenue Northwest
Washington, D.C. 20016

Accredited Member National Home Study Council

GI Bill

CREI programs are approved for training of veterans and servicemen under the G.I. Bill



TABLE I
RADIO-ELECTRONICS PRODUCT TEST REPORT

Manufacturer: **Bigston**

Model: **BSD-300**

CASSETTE TAPE DECK MEASUREMENTS

	R-E Measurements	R-E Evaluation
FREQUENCY RESPONSE MEASUREMENTS		
Frequency response, standard tape (Hz-kHz \pm dB)	35-10, \pm 3 dB	Poor
Frequency response, CrO ₂ tape (Hz-kHz \pm dB)	32-8, \pm 3 dB	Poor
DISTORTION MEASUREMENTS (RECORD/PLAY)		
Record level for 3% THD (1 kHz) (dB)	Standard/CrO ₂ + 8/+ 8	Excellent
Harmonic distortion @ -3 VU (1 kHz) (%)	1.0/0.85	Excellent
Harmonic distortion @ 0 VU (1 kHz) (%)	1.0/0.85	Very good
Harmonic distortion @ +3 VU (1 kHz) (%)	1.3/1.0	Very good
SIGNAL-TO-NOISE RATIO MEASUREMENTS		
Standard tape, Dolby off (dB)	unweighted/weighted "A" 56/60	Excellent
Standard tape, Dolby on (dB)	64/67	Excellent
CrO ₂ tape, Dolby off (dB)	61/65	Excellent
CrO ₂ tape, Dolby on (dB)	68/72	Excellent
MECHANICAL PERFORMANCE MEASUREMENTS		
Wow and flutter (% WRMS)	0.06 (0.09 RMS)	Excellent
Fast wind and rewind time, C-60 (seconds)	74	Fair
COMPONENT MATCHING CHARACTERISTICS		
Microphone input sensitivity (mV)	0.17	
Line input sensitivity (mV)	120*	
Line output level (mV)	500	
Phone output level (mV)	40 (8-ohm load)	
TRANSPORT MECHANISM EVALUATION		
Action of transport controls		Very good
Absence of mechanical noise		Good
Tape head accessibility		Average
Construction and internal layout		Good
Evaluation of extra features, if any		Very good
CONTROL EVALUATION		
Level indicator(s)		Fair
Level control action		Fair
Adequacy of controls		Fair
Evaluation of extra controls		Good
OVERALL TAPE DECK PERFORMANCE RATING		Good

ing four possible combinations. (Figure 1 shows a prototype unit that has a single bias/equalization button. The production model separates the two functions.) Both buttons are in their out position for standard low noise tape and both should be depressed for CrO₂ (or equivalent) tapes.

Large, dual concentric RECORD LEVEL controls are active in the record mode but do not affect the playback output level which is fixed. At the right are a pair of microphone input jacks (that accept standard 1/4-inch diameter phone plugs) and a stereo headphone jack for monitoring source signals or for listening to recorded tapes via phones. Inserting microphone plugs in the mic jacks deactivates the rear panel high-level line inputs, so mixing of mics and line inputs is not possible with this deck. Of course, one could use a mic in one channel and a line input in the other. In addition to the line-in jacks, the rear panel of the unit contains the required pair of line-out phono-tip jacks.

Laboratory measurements

Table I summarizes our laboratory test results. In all of our tests, we used TDK-Audua C-60 cassettes as our standard for low-noise, high output and TDK-SA C-60 cassettes as an equivalent for the CrO₂ tape settings. As many readers probably know, TDK-SA tape and the newer Maxell UD-XL-II, while basically ferric particle tapes, are designed so that they require the higher bias normally associated with the CrO₂ tapes that some companies are phasing out of their product lines because of recent improvements in ferric tape formulations.

Most of the results obtained were extremely impressive, especially for a tape deck in this low price category. Our only disappointment came when we measured frequency response using both grades of tape. The frequency response for the TDK-Audua sample is plotted in Fig. 2 and is seen to

TABLE II
RADIO-ELECTRONICS PRODUCT TEST REPORT

Manufacturer: **Bigston**

Model: **BSD-300**

OVERALL PRODUCT ANALYSIS

Retail price	\$169.95
Price category	Low
Price/performance ratio	Good
Styling and appearance	Excellent
Sound quality	Fair
Mechanical performance	Excellent

Comments: If our overall evaluation of this low-cost deck seems particularly negative (considering its low price and the fact that it does incorporate Dolby noise reduction at that price) it is because there is so much that is good about this unit that we were particularly disappointed at its very poor record/playback frequency response. If that response could be tweaked up to, say, 14 kHz or 15 kHz when used with top-grade tapes (and we have a feeling that it could be, very easily), the other parameters such as signal-to-noise, headroom, harmonic distortion and wow-and-flutter are all so superior to anything found in this price category that the unit would be a most outstanding buy.

We suspect that in our sample, the cue/review feature was not operating properly for, instead of rewinding when this button was depressed (with play button depressed too), the tape simply came to a standstill. The fast forward cueing feature worked well, however, and is a handy added feature that permits one to reach a desired point in the tape without having to go through the stop mode. Record-level meters are rather on the small side and in our sample, there was a 15 dB discrepancy between left and right meters when input levels to both channels were identical and level controls were at maximum. The manner in which the front-loading cassette compartment is arranged makes for fool-proof insertion of cassettes and a ledge up front forestalls cassettes from popping out on to the floor when the eject button is pushed (a failing on some other front-loaders we have seen). In summary, then, the Bigston BSD-300 is in many ways equal to cassette decks costing much more—but that limited frequency response range prevents us from concluding with overall raves for this product.

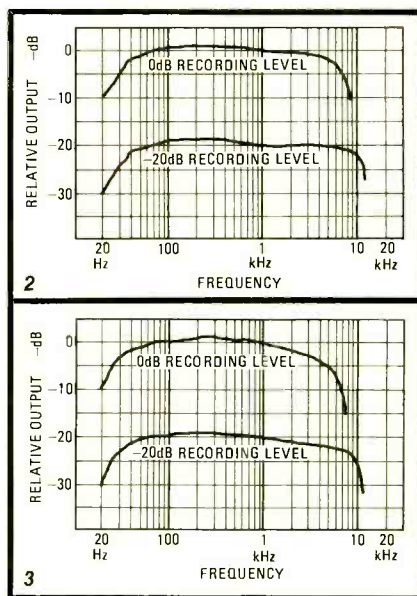

extend only from 35 Hz to 10 kHz \pm 3 dB at the nominal -20 dB record level used in one of our tests. The frequency response for record/playback of the TDK-SA tape was even poorer, as can be seen in Fig. 3. Normally, we would have expected the response to be somewhat better for this tape, as it has in fact been on almost all other

continued on page 84

Analog Voltmeters

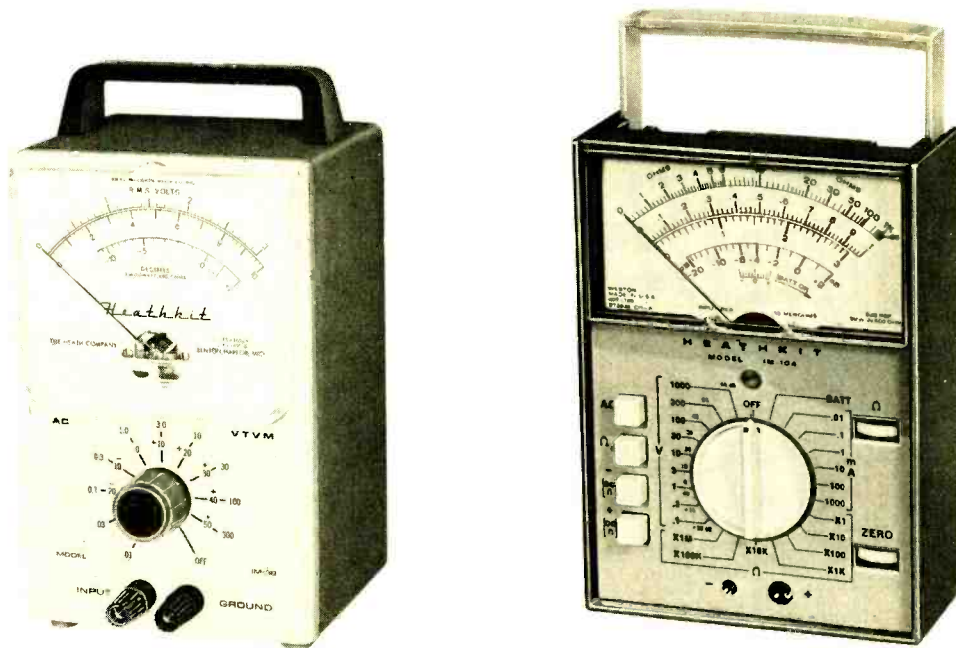

*Part II. The analog voltmeter is alive and well.
Here's a rundown of the different types currently
available—their features, specifications and applications*

CHARLES GILMORE*

LAST MONTH, IN PART I OF THIS ARTICLE, we discussed the different types of analog voltmeters that are currently available.

This month we will cover the various features of these voltmeters and the meaning of their specifications.

The ammeter circuit

The most common form of ammeter on TVM's is the simple shunt. The TVM offers the advantage of high gain and low insertion loss. Since the VTVM has an insertion loss of 1 to 1.5 volt for a shunt, ammeters are not normally included in VTVM's. When shunt ammeters are used, the DC and AC ammeters are very similar. The change from AC to DC consist of selecting the correct shunt to be placed across the voltmeter.

Even though the shunt insertion loss can be kept low with a meter having sensitive ranges (0.1 volt, for example), the shunt resistance becomes large for the sensitive current ranges. For example, a meter with 0.1 volt sensitivity has 10,000 ohms in-

sertion resistance for the 10- μ A full-scale range. On the same meter, the 1-ampere range has a 0.1-ohm shunt. Due to other series resistances, the 1-ampere range might have an insertion resistance of 0.2 ohms or more.

The TVM ammeters appear in two other, less frequently used forms. First, the scheme shown in Fig. 9-a. In this circuit, an operational amplifier is used as a current-to-voltage converter. The unknown current is introduced to the summing junction of the operational amplifier. This current is nulled by an equal amplitude but opposite polarity current developed by the output voltage of the operational amplifier across the feedback resistor. As this current is flowing through the feedback resistor, the voltage drop across the resistor is directly proportional to the resistance and the unknown current. The output voltage of the operational amplifier (the voltage across the resistor) is then measured with the TVM voltmeter. Since there is no voltage drop at the input to the null amplifier, this technique offers the advantage of essentially zero input impedance.

Figure 9-b shows schematically the

technique developed and patented by Weston for current measurement in their model 670 TVM. This TVM features in-circuit current measurements. Measuring the current does not require opening the circuit, a considerable inconvenience with other ammeters. The circuit relies on the inherent resistance in the circuit conductors. The voltage drop across the circuit conductors is reduced to zero by a current equal in amplitude and opposite in polarity to the unknown one. This "bucking current" is maintained at exactly the correct value by the null amplifier.

This technique requires a special pair of two-terminal probes and is especially useful for measuring currents in printed circuit board foils. Both these latter techniques are applicable only where the currents being measured are low enough so the measuring circuit can produce an equal and opposite current, and where DC currents are being measured.

The TVM ohmmeter circuit

The simple and most frequently used ohmmeter circuit for TVM's is identical to the series-resistance type of the VTVM. The newer and more elegant TVM's fea-

*Manager Design Engineering, Heath Co., Benton Harbor, MI.

ture a dual-range ohmmeter circuit which has a choice of two open-circuit voltages. A low-voltage range is provided so semiconductor junctions (both germanium and silicon) are not forward-biased. The maximum open circuit voltage of such ohmmeters is about 0.085. The high-voltage range of these ohmmeters is usually 1.5 volts and can easily forward-bias a semiconductor junction.

These two circuits are constructed in two different ways. First and simplest, the low voltage is obtained by reducing the 1.5-volt ohmmeter battery to the low voltage by a voltage divider circuit. This effectively yields a low-voltage source with a 10-ohm series impedance. Alternatively, the test signal is derived by applying a constant current source to a resistor as shown in Fig. 10. In this circuit, the constant current source is applied to the basic range resistor (say 10 ohms). The value of the current flowing through this resistor determines the maximum open circuit voltage of the ohmmeter. If the 10-ohm resistance is shunted with an unknown resistance, the voltage drop across the resistor is determined by the parallel value of the two resistors. A two-range constant-current source is used for high/low measurements. The constant-current technique permits simple control of the maximum open circuit output voltage of the ohmmeter.

The AC voltmeter

A specialized form of electronic analog voltmeter amplifies and measures only AC voltages. The AC voltmeter finds special application in laboratory work. It is also part of the standard test equipment used in audio service work. The AC voltmeter is characterized by high sensitivity (compared to the ordinary VTVM or TVM), a voltage-only function, extended frequency response, alternate calibration in dB (usually dBm) and of course AC-only response.

The major difference between the AC voltmeter and the other types discussed lies in the amplifier. As DC voltages are not being measured, they need not be amplified. This allows an amplifier design with considerably more gain but without the worries of DC drift which accompanies a high gain DC amplifier.

The input attenuator of the AC voltmeter is similar to the attenuator described for that AC portion of the TVM. On AC voltmeters with extended frequency response, the input attenuator is often divided into two portions. The first portion is a compensated attenuator providing decade attenuation. Finer attenuation follows an input buffer stage. This is a lower-impedance attenuator and does not need compensation. A specialized form of AC voltmeter offer linear response to logarithmically changing signals. That is, the voltmeter is calibrated linearly in dB and logarithmically in voltage. Such a meter has an additional logarithmic converter placed between the rectifier and the meter circuit. Low-noise amplifier design is required for the amplifiers used for the AC voltmeter.

VTVM AC and DC voltage ranges

The voltage ranges of the VTVM are most common in 1.5-5-15 sequence. This

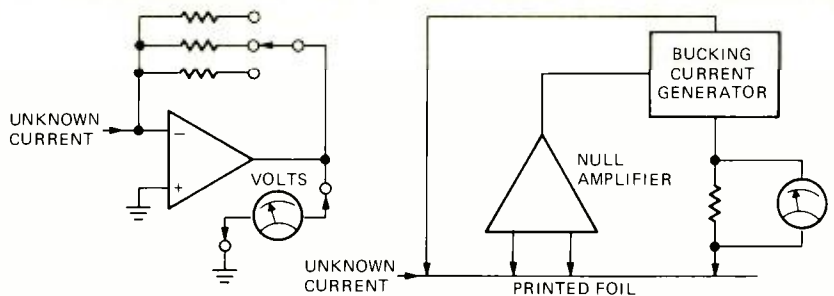

FIG. 9—TWO SPECIAL CIRCUITS for measuring current. Operational amplifier used as current-to-voltage converter is shown in a. Ranges are selected by the feedback resistor. The patented Weston circuit that sets up a bucking current equal to the unknown one and then measures the bucking current is shown in b.

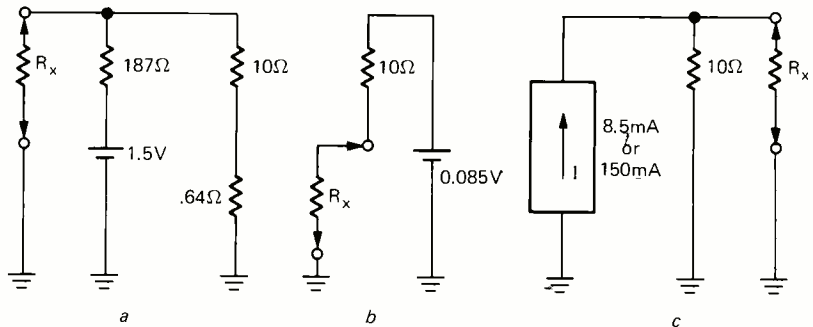

FIG. 10—TWO TYPES OF TEST SIGNAL generators for TVM ohmmeters. Battery and voltage divider combination is shown in a; equivalent circuit is shown in b. Constant-current generator is shown in c.

is a modification of the 1-3-10 sequence and is chosen because the steps represent 10 dB voltage changes. This is convenient when working with AC signals, and most VTVM's have a dB scale for this purpose. The 0 dB level is 0.774 volts (1 mW on 600 ohms). Figure 11 shows a typical VTVM scale. Occasionally VTVM's are found with a 1-3-10 sequence.

Normally the most sensitive range of the VTVM is 1.5 volts. The 1.5-volt AC range may require special calibration to correct for the nonlinearities of the rectifier when operated at this low input level. The 1.5-5-15 sequence also permits the user to make all measurements in the upper two-thirds of the scale, where the meter is most accurate.

The full scale of 150 volts AC is also handy in countries where a nominal 115 to 120 VAC power-line voltage is used, as measurements of the line voltage are made in the upper third of the meter scale. Needless to say, this advantage disappears when the common line voltage is 200 to 240 VAC. VTVM's have an upper voltage limit of 1,000 to 3,000.

Input impedance

Input impedance for the VTVM is generally specified separately for the AC and DC modes. The general purpose VTVM has an 11-megohm input impedance. Although the 11-megohm input is the most common, other input impedances are used. There is little or no significant difference between the VTVM with 11 megohms and the VTVM with 13-megohms input impedance. There is, however, a significant advantage with the VTVM that offers an input impedance in the hundreds of megohms. Such a high input impedance costs money!

If the VTVM is to be used with a high-voltage multiplier probe, then its input

impedance, with probes disconnected, must be some standard value. The accuracy of the input impedance is of no consequence unless a multiplier probe is being used. Often the accuracy of input impedance is not specified, or a simple note stating the attenuator is composed of 1% tolerance resistors is given. Remember, a VTVM which has 11 megohms input impedance with one megohm in the probe must be calibrated for that series impedance. The direct input to the VTVM without the calibration at these points sensitive by an extra 10%.

The VTVM AC mode input impedance is one megohm, except on the expensive VTVM's, which use the same attenuator for the AC and DC modes. The AC input specifications also include the value of shunt capacitance across the input terminals. This figure does not include the probe capacitance, and therefore is simply an indication of the lowest capacitance achievable with special care.

Accuracy

The accuracy specifications of both the AC and the DC modes of the VTVM are given as a percentage of full scale. This is a good reason to keep the measurements as close to full scale as possible. Accuracies of $\pm 1\%$ to $\pm 3\%$ are common for the DC ranges and $\pm 2\%$ to $\pm 5\%$ are common for the AC ranges. The lowest AC range may have a separate error specification due to the nonlinearity of the rectifier at low forward voltages. Accuracy of course depends to a great extent on the price paid for the VTVM. Accuracy also diminishes with time and environmental conditions such as temperature and humidity.

Accuracy specifications of the ohms function are given in one of two ways. On the lower-cost VTVM's, the ohmmeter

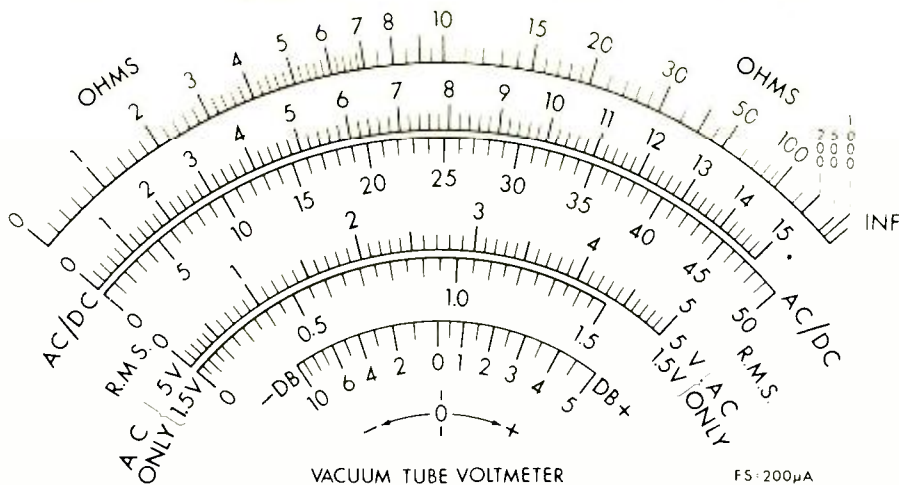

FIG. 11—A TYPICAL VTVM SCALE. Center-scale reading is 10 ohms or a multiple; non-linearity is well shown. Note the special low-voltage scales for AC.

accuracy is indicated by noting the accuracy of the resistors used in the measurement circuits. This indicates an error about the center scale value of the ohmmeter. The error at other points must be calculated. The lowest ohmmeter range does not have the indicated accuracy, due to variations in the battery internal resistance. Accuracy also depends on the preciseness of the ohmmeter scale calibration.

The alternate mode of accuracy specification notes the accuracy as a percentage of the mid-scale reading. VTVMs with such a specification have different specification values for the first range and other ranges of the ohmmeter. A 2 to 5% accuracy figure is common.

Frequency response

Although the accuracy of the AC mode of the VTVM is given as a percentage of full scale, this specification must be further qualified by a frequency range. The most common method of specifying frequency response is to indicate the frequency range over which the response will not vary more than ± 1 dB when referred to a low-impedance 60 Hz source. The common frequency range for the low-cost VTVM is 25 Hz to 1 MHz. Higher upper frequency limits can be had for additional cost. The Hewlett Packard 410B has a 20 Hz to 700 MHz specification, for example, and costs \$275.

Ohmmeter ranges

As noted earlier, ohmmeters conventionally used in the VTVM are specified with a center-scale value, usually 10 ohms. The ohmmeter is ranged in decade steps from this point up, $R \times 1$ megohm being the upper limit. This gives usable measurements in the vicinity of 100 megohms.

Probes

The VTVM is normally supplied with some form of probe. In many cases these probes are either attached to the VTVM or have connectors or characteristics of such a special nature they must be used only with the original model of VTVM. As noted before, the DC probe often has an internal 1-megohm resistance at the tip. If one probe is used for all modes of the VTVM, the probe is switched at the tip.

Alternatively, separate leads may be supplied for the DC and AC/ohms functions. There is always a separate lead for the common or return path. Some specialized VTVMs offer an additional probe for extended high-frequency operation. The mechanical ease and flexibility of the probe are important to consider when purchasing the VTVM.

Controls

The VTVM has two front-panel controls in addition to those for selecting range and function. These are the zero control and the ohmmeter adjustment. The zero control balances the meter electrically when the test leads are shorted together. This control can also move the meter from left zero to center zero, permitting readings of a signal that passes through zero volts. This feature is particularly handy for null detection.

The ohmmeter adjustment sets the full-scale sensitivity of the voltmeter when used in the ohmmeter function. This feature is necessitated by the variations in the battery used for the ohmmeter voltage source.

The function switch selects AC, +DC, -DC, and ohms. The \pm selection of the DC mode is useful as it eliminates the need to reverse the test leads. Often reversing the test leads is not practical as it is with the conventional VOM, as the common test lead may be connected to earth ground. If the common lead is not connected direct to earth ground, the impedance to ground (especially the capacitive component) may be quite low. Either situation will cause considerable disturbance to the circuit under test if the voltage source in the circuit is connected to the common lead.

The TVM—voltage ranges

The typical scales for a VTVM are shown in Fig. 11. Decibel, peak-to-peak, and zero-center scales are given for special applications. Often meter scales are color-coded for ease of interpretation.

Three different range sequences are commonly used for the TVM. The 1-3-10 seems the most common at present. These meters start at 0.1, 0.3 or 1 volt and extend to 1,000 or 3,000 volts. A few TVMs use the 1.5-5-15 sequence, and cover approximately the same voltage

range. When a very low cost TVM is designed, the scales may run in a 1-10-100 sequence. Such units start with a 1-volt range and go to 1,000 volts. The 1-1-10 sequence is the most practical when working with voltages found in solid-state circuits.

Accuracies

Accuracy for the TVM, like accuracy for the VTVM, is given as a percentage of full scale, and is given separately for the AC and DC voltage modes. DC accuracies are in the $\pm 2\%$ to $\pm 3\%$ area. The accuracy of the DC voltmeter is further limited by environmental factors and possibly the position of the meter.

The AC accuracy lies in the $\pm 2\%$ to $\pm 5\%$ of full scale area, with accuracy being very proportional to price. Accuracy is either specified at a particular frequency or specified over a limited band of frequencies.

Ohmmeter accuracy is much the same as the VTVM ohmmeter accuracy. That is to say, it has a specification indicating a percentage of the mid-scale figure. Accuracies are in the area of 5% for TVM ohmmeters. An alternate method of ohmmeter specification indicates the accuracy in degrees of arc of meter swing. This method of ohmmeter specification is one of the most descriptive. An ohmmeter specification of ± 3 degrees of arc is common, on a meter with 100 degrees of swing. Further limitations are given for very low values of resistance.

Frequency response

The frequency response of the AC voltmeter portion of the TVM may be given in a number of ways. The specification may be identical to the AC accuracy specification of the VTVM, with AC accuracy specified at a particular frequency (and usually with a low driving impedance) and a frequency response characteristic of plus/minus a number of dB given for a range of frequencies.

Response limits of ± 1 dB or ± 2 dB are common for TVM specifications. ± 1 dB is approximately $\pm 10\%$ error. The specification may be given as error due to the influence of frequency (for example $\pm 5\%$, 40 Hz to 10 kHz), or the frequency response may be given graphically. The graph plots dB error vs. log frequency.

When limited specifications, such as those in a distributors catalog, are given, the actual numerical values of the frequency response may be omitted. In this case, the meter may have only a frequency range specified, or perhaps a simple error specification on the AC ranges. In the latter case, this error figure should not be taken as the error figure including frequency response, but more as an idea of the error at some fixed frequency such as 60 Hz. Note that the frequency response of the TVM is much more limited than the response we have come to expect from the VTVM. Where the VTVM is specified to one or two megahertz, the upper limit of all but a few of the TVMs is 10 to 100 kHz. When buying the TVM, pay close attention to this upper specification of frequency response if you need accurate measurements at the upper end of the audio spectrum. A meter that stops at 10 kHz may not suffice. *continued next month*

R-E's Service Clinic

Screen controls

Obscure reactions

JACK DARR
SERVICE EDITOR

COLOR TV SETS ARE FULL OF JOLLY LITTLE surprises for us. Some of them are really obscure and some of them are so obvious that we overlook them. We rely heavily on symptoms and reactions for our diagnoses. The picture-tube section of the set has some really good ones. Here's one of the most popular (??) (This column was prompted by a surprisingly large amount of letters on just these symptoms and reactions!)

In the stock tube circuit, the picture-tube cathode voltages are determined by the plate voltage and current of the video-output tube. If we pull this tube, or if the tube is dead, no plate current can flow. Without a load the plate voltage promptly rises to the supply level, which is usually about +400 volts. (See Fig. 1.) Since this point is directly connected to the picture-tube cathodes, their voltage goes more positive also.

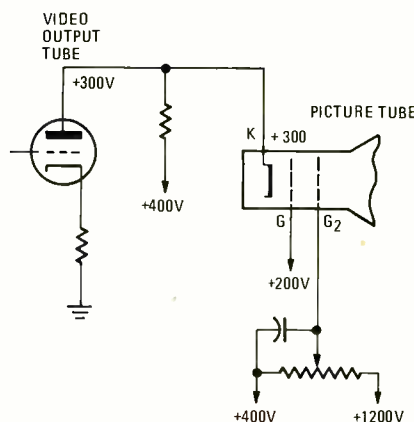

FIG 1

Since the picture-tube grids have presumably been unchanged, the cathode voltage going up makes the grids far more negative. Normal ballpark DC voltages are: +300 volts for the cathodes and +200 volts for the grids. This results in a net bias of -100 volts. If the cathode voltage increases to +400, we now have a bias of -200 volts. The raster promptly blacks out because the picture tube is completely cut off.

Or does it? What if we pull the video-output tube or it goes dead and we still have a raster? This is a *reverse* reaction to what we ought to see; it gives us a very useful clue. If the raster doesn't go

out, this is telling us that the picture tube is *not* cut off, and it ought to be. Something has changed the cutoff voltage. (Have you got it yet? What affects the cutoff voltages of the picture tube?)

The answer in almost all cases is a simple one. One other voltage has a great effect on the cutoff point of the picture tube, and this is the *screen grid voltages*. If these are set too high, you will still see a raster. One more good clue here; you will not see any video though you may have sound. If the screen voltages are raised to their maximum level, somewhere around 900-1,000 volts, the cutoff point of the tube will be raised to the point where even the -200-volt bias won't kill the raster.

Why? Very simple. Someone has turned all three of the screen controls wide open! This first happened to me a long time ago. The set came in with the symptoms just described—zero plate current in the video-output tube, no video and a raster. The no-current problem turned out to be a contrast control that was wide open. Since this control is the cathode resistor of the video-output stage, this stopped things dead. Further checking (and some little elapsed time!) showed that all three screen controls had been turned full open.

This can happen when a novice technician can't think of anything else, so he turns the screen controls full on. It can also happen if a child gets behind the set and turns the pretty little red, blue and green controls. (Age anywhere between about 10 and 60 or so.) So; when you get this kind of reaction, don't go looking for complicated things yet. Check the setting of the screen controls. Fix the problem in the video stage, run a grey-scale setup adjustment and you're back in business.

My own pet method of setting these controls is to turn each one till I just see a line. Then back up till it has just gone out. This gives you a little better equalization of the three screens. In the sets that do not have a SERVICE switch, you can use the same method. Turn the brightness to about 25% on and bring each screen control up till you can barely see a raster, then back it off till it

This column is for the service technician's problems—TV, radio, audio or industrial electronics. We answer all questions submitted by service technicians on their letterheads individually, by mail, and the more interesting ones will be printed here.

If you're really stuck, write us. We'll do our best to help you. Don't forget to enclose a stamped, self-addressed envelope. If return postage is not included we cannot process your question. Write: Service Editor, Radio-Electronics, 200 Park Avenue South, New York, NY 10003

disappears. This gives the same results. From here on, setup is the same as before. If dark areas of the picture show color, back off the screen control for that color. If the lighter areas (whites) show color, adjust the drive controls until these are a good white.

Other reactions

Excessively high screen-voltages can cause other problems that are not so obvious. Among these are retrace lines that won't go away as they should with brightness and contrast properly set up. In some cases, excess blooming can be caused by a high screen voltage. Before going through a lot of other and more difficult tests, run a grey-scale setup adjustment and see if this won't solve the problem. This can save a lot of time.

This can work the other way, of course. If none of the screen controls will give you a line or raster on setup and yet you get a dim raster with the SERVICE switch in the NORMAL position, check to see if the screen-grid voltages are up to normal. Read these on the sliders of the screen controls or on the picture-tube socket. In the stock circuit, all three controls will have the boosted-boost (B++) of 1,000-1,200 volts on one end and B+ of about +400 volts on the other. If the B++ rectifier that is almost always (or always, I'm pretty sure) a solid-state diode is down a little, this will reduce the B++ voltage and the screens won't be able to reach the correct voltage. Quick-check: see if B+ and the raw boost are normal. The boost should be about +850 volts. If these are OK but B++ is low, try a new diode unit. This is practically a dry circuit—there is hardly any measurable current flow aside from the bleeder current through the high-resistance screen controls and these go back to B+. Large resistors can be used. If you find one of these that is too hot, look out for leakage somewhere!

Another cute one is the bypass capacitors that are usually connected from the sliders of the screen controls back to the low end. If one of these is leaky or shorted, you won't be able to get that screen up to normal voltage. This is one possible cause for the "two colors make lines on setup but the other one won't" symptom.

Ballpark figures for a typical 21-25-inch picture tube will be +300 volts on the cathodes, +200 volts on the control grids and about +700 volts on the screens. You will find sets with the same tubes using lower DC voltages! So, check the schematic before you start tearing things up!

It's always a good idea to check the bias voltages on the picture tube when you run into unusual reactions involving low high-voltage, dim raster and similar

symptoms. The typical maximum beam-current for the picture tube runs somewhere around 1.3-1.4 mA. So, it doesn't take too much of an upset in bias to overload the high-voltage supply and cause problems. R-E

reader questions

SCHEMATIC FOR COLOR BAR

I've a problem of horizontal instability in an Amphenol model 860 color-bar generator. I've checked everything I can with no results. I don't have a schematic. Do you?—P.C., New York, NY.

Sorry to say that I don't. If any of the readers has a schematic of this instrument, it would be appreciated by Peter Campione, 32 Jones St., New York, NY 10014. (Also by Jack Darr, Service Editor, for his files!)

DEAD HORIZONTAL OSCILLATOR

No high-voltage, no bias on horizontal output! This is a Wards GC1-1724 A. I know the horizontal oscillator isn't running! I've changed the sinewave coil and the horizontal oscillator coil. No go. Help, help! Customer mad also!—L.H., Detroit, MI.

Don't get mad at it; it's just a machine! Go back over all of the things you've tried and recheck. Also, check

LECTROTECH 50 MHz FREQUENCY COUNTER

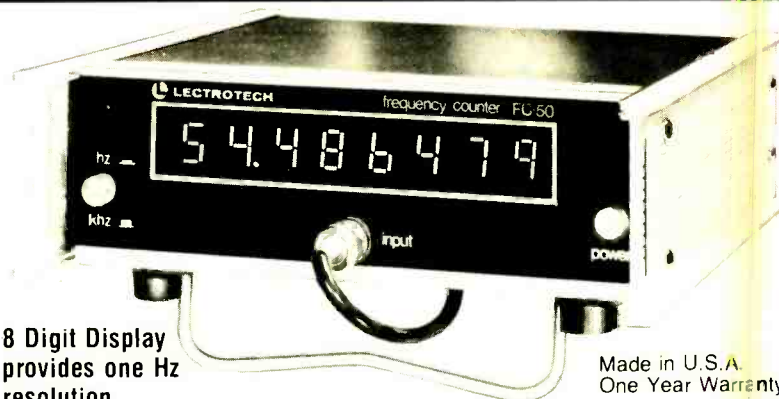

- 8 Digit Display provides one Hz resolution
- 50 MHz Guaranteed

Made in U.S.A.
One Year Warranty

FC-50 Frequency Counter is the ideal instrument for measuring frequency and adjusting CB, Business Band, Marine and other radio receivers and transmitters up to 50 MHz including scanner crystal frequencies.

- 8 Digit Display eliminates the need for overflow, no memorizing of first 2 most significant digits.
- Operates from both AC and DC power sources. FC-50 is capable of operation from 12 volt DC source such as auto battery with optional cigar lighter attachment. Permits CB frequency checks directly in vehicle. (Other accessories available for complete CB servicing)
- New LSI (Large Scale Integration) frequency counter circuitry provides precise accuracy in servicing and greater reliability at lower cost to you

\$199.50

net only

SPECIFICATIONS:

Frequency Range: 10 Hz to 50 MHz. **Number of Digits:** 8 full digit display. **Digit Size:** 0.5 inch. **Resolution:** 1 second gate—1 Hz. 1 m-sec gate—1 KHz. **Gate Times:** 1 second and 1 milli second. **Sensitivity:** 30 mv RMS to 40 MHz. 50 mv RMS 40 to 50 MHz. **Input Impedance:** 1 megohm and 30 pf. **Connector:** Front panel BNC. **Input Protection:** Max Input, DC and AC Peak. Frequency Range—10 Hz to 100 KHz./250 Volts, 100 KHz to 5 MHz./100 Volts, 5 MHz to 50 MHz./50 Volts. **Line Voltage Stability:** Better than ±1 PPM after 30 min warmup. **Time Base Stability:** ±1 Hz. **Temperature Stability:** Better than ±10 PPM from 0-50 Deg. C. **Power Requirements:** 105-130 V. 60 Hz. 15 Watts max., or operation from 12 volt car battery with optional cigar lighter attachment cord. **Size:** 2.5 x 8.25 x 8.25". **Weight:** 4 lbs. **Handle:** Combination carrying handle and tilt stand.

See your distributor or write:



LECTROTECH, INC.

5810 N. Western Ave., Chicago, Illinois 60659 (312) 769-6262

CIRCLE 78 ON FREE INFORMATION CARD

for signal on the DC voltage supply. A feedback loop here, due to an open filter, can upset the oscillator. (Feedback: "Better glad than mad! I had replaced C521. Turned out that the one I replaced it with had died on the shelf! Thanks for the help." Note: C521 was not an electrolytic, as I assumed at first. It was the 390-pF coupling capacitor in the horizontal oscillator circuit! These can go bad, too.)

HORIZONTAL OSCILLATOR SUPPLY?

I can't see where the plate voltage comes from, for the horizontal oscillator, in circuits like a Motorola TS-921. It is fed from the boost; there isn't any boost until the oscillator starts, is there? So, this is a chicken-and-the-egg question to me. Which comes first and how does it get there?—M.M., Madras, OR.

This causes a lot of confusion among technicians (including me, for far too long). The secret lies in the fact that there *is* DC voltage on the boost line, even though the horizontal oscillator and output are not running.

This voltage comes "through" the damper tube. Its plate is tied to B+. As soon as this tube warms up and starts to conduct current, DC appears on the flyback, and also on the plate of the horizontal oscillator. This voltage *must*

be present at normal value on the damper cathode or nothing can work. It will be high enough to start the oscillator and let the output tube conduct.

COLOR PROBLEMS

This Philco-Ford 20KT40B chassis has had repeated loss of color problems for quite a while. It seems to be in the 3.58-MHz oscillator IC. The DC voltages on pins 1 and 7 are high. The supply voltage is a little high, too. 23 volts instead of 20.0. What do you think?—D.N., Baton Rouge, LA.

I think two things right at the moment. One, I think this IC is shorted or damaged internally. The DC voltages on pins 1 and 7 come "from inside the IC". Whenever any of these are quite a bit off, as they are here, this indicates internal problems. Second, I think the supply-voltage situation should be checked. This voltage should be brought down to the rated 20.0 volts. Over-voltage operation could be the cause of the repeated failures in this circuit.

(Feedback: reader says "Bingo!" That did it.)

ROLL AND DIM-OUT

The raster shrinks, then the picture starts rolling, then it gets dimmer and goes dark; this is in an RCA CTC-53. At the shop, I had to raise the AC line

voltage by 10 volts to make it show up. What could be affecting all of these things at once?—J.M., Evanston, IL.

There is one thing that could affect the vertical size, the sync and the brightness all at once in this chassis. This is the boost voltage. It affects the picture-tube screen, and also feeds the input half of the vertical oscillator. So, if the boost is dropping, this is the kind of symptom you would see. (Just for luck, check the 31LZ6 horizontal output tube. We have found some of these with gas or grid emission, etc.)

TRANSISTORS OVERHEATING

While testing an RCA Stereo, a YVD-994, on my bench speakers (4-ohm), I noticed that the output transistors got very hot. The emitter-collector voltage across the transistors would drop to less than 0.5 volt at high volume. What is causing this?—S.R., Macogdoches, TX.

This overheating at full volume *under these conditions* is normal. The speaker rating on this model is 8 ohms. If you try to run the amplifier into a 4-ohm load, it will try to develop the same amount of power. This means that the collector current will be *double* the normal amount. You're "bottoming" the power transistors. Output-transformerless (OTL) stages in class B or AB, which these are, draw much more current with

IN WIRE-WRAPPING HAS THE LINE... HOBBY-WRAP-30 FOR AWG 30 WIRE ON (.025 SQUARE POST)

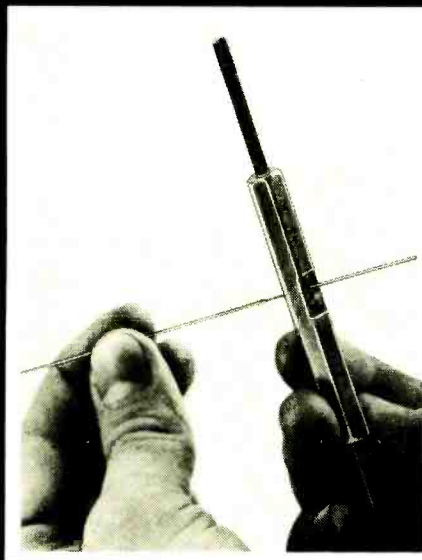

STRIP



WRAP

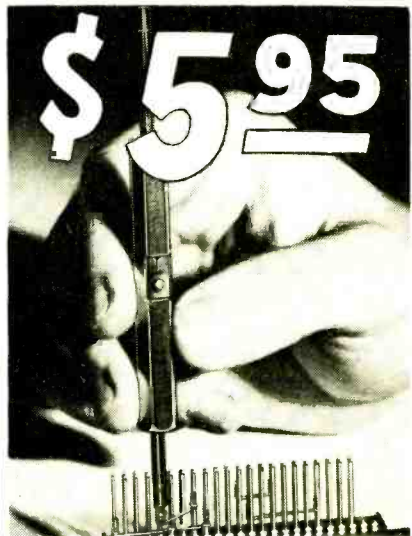

UNWRAP

OK MACHINE & TOOL CORPORATION

3485 CONNER STREET, BRONX, NEW YORK, N.Y. 10476 U.S.A. • PHONE (212) 994-8600

TELEX: 125091 TELEX: 232395

a high signal level than they do at rest or no-signal.

You can always use a greater load impedance, but don't go below rated load or short the outputs. This can damage the output transistors.

REPLACEMENT TRANSISTOR TRICK

I'd like to know what transistors will replace these: A634 and C1096. That's all the markings; they were in a little orphan stereo.—C.W., Graham, WA.

There's a little trick you can use with some of these import transistors when seeking replacements in Substitution Guides. If you look under "A634" and get zlich, try adding "2S". Looking under 2SA634, you'll come out with something like a Sylvania ECG-187. These seem to be complementary-symmetry, so the other one would be an ECG-186. In RCA, SK-3083/SK-3054.

HORIZONTAL OUTPUT TUBE GLOWS RED

The horizontal output tube in this G-E G1 chassis glows red, and the fuse blows. I can get high voltage by driving the plate lead to the flyback with an Analyst. Doesn't this clear the flyback and other circuits?—J.M., Nashville, TN.

Yes! From the symptoms, you've lost the grid drive to the horizontal output

tube. Check to see if you get the normal -60 volts on the 21LG6 grid. If not, check the horizontal oscillator. We have had some troubles with intermittent-starting oscillators. Try replacing the capacitors across the oscillator coil. Use exact replacements.

(Feedback: .0033- and .0068- μ F capacitors replaced and she plays pretty! Thanks.)

NO COLOR

Here's one for you: An Admiral 2K2084 with no color. All color circuits seemed to check out OK. Color very pale at maximum-on color control: some slight barber-pole effect. Finally checked the tint control and found it open. When the slider hit the bad spot, it bridged it and the color came back. New control fixed the whole thing. Have you ever run into this one?—L.S., Brunswick, OH.

Not exactly, but I'm glad to get the data for future use.

REPEATED DAMPER BLOWING

This Magnavox T940 chassis has a bad habit; it blows the damper tubes at assorted intervals. This is getting monotonous. What can I do? I noticed that the last tube that blew had a small blob on the end of the cathode ribbon. Does this tell us anything?—W.M., Phoenix, AZ.

Yes, indeed! The blob on the end of

the cathode ribbon means that this was blown out by a sudden heavy pulse of current. This is NOT likely to come from something inside the damper tube itself. Look for something that would indicate an arcover; maybe in the 6JE6 tube, boost, or anywhere in the high-voltage circuitry. Try tapping things.

(Feedback: It worked! I put a 1/4-ampere fuse in the damper plate and then started tapping things. At first I got nothing, then after the set had warmed up a little more, I tapped the 6JE6! There was a flash inside it, and the fuse blew. It's been working ever since with a new 6JE6! Thanks.)

BULLSEYE!

You told me to look for an intermittent connection around the horizontal oscillator circuit, when I asked about reasons for the damper tube in this set turning red hot. Bullseye! The oscillator coil had a very intermittent connection due to a crack in the PC board. The customer told me why. He and a friend had the set out on the floor, trying to test tubes, and his 4 year old son dropped a pop bottle in it! What next?—P.T., Chicago, IL.

What next? Goodness only knows!

SERIES-HEATER BREAKDOWN

A Magnavox T931 keeps blowing 12AT7 tubes! This shuts down the whole

NEW

FROM
ok[®]

THE
HOBBY~WRAP
COMPLETE WITH BIT AND SLEEVE
ONLY **\$34.95**

Now you, the hobbyist, can do wire-wrapping professionally with our easy to use Hobby-Wrap gun.

025 sq. post,
AWG 30 wire
(batteries not included)

OK MACHINE & TOOL CORPORATION
3455 Conner St., Bronx, N.Y. 10475 / (212) 994-6600 / Telex 125091

Model
BW-630

CIRCLE 33 ON FREE INFORMATION CARD

www.americanradiohistory.com

FEBRUARY 1977

81

thing since it's a series string. I replace it and the thing works for a while, then pow; same 12AT7 out. I found a couple of bad capacitors, but this didn't help.—G.B., Seattle, WA.

This used to be quite a common problem in series-heater string sets. The most likely cause is a heater-cathode short in the *next* tube in the circuit! This will put a much higher AC voltage across the tubes remaining between this point and the input. In this circuit, it would be V1, the 4EH7 1st IF tube.

(Feedback: Right on! That was it.)

VERTICAL RETRACE

I can't get rid of the vertical retrace

lines on this Magnavox T908 black-and-white set. The blanking-gate Zener diode had been broken and replaced by someone else. It connects from the collector of the vertical output to the +420-volt boost. All of the DC voltages seem to be a little low, too. The picture tube heater is only 5.1 volts instead of 6.3. Is this significant?—G.R., Pine Bush, NY.

You seem to have two problems! The low voltage isn't significant; probably due to low line-voltage since even the AC voltage to the picture tube heater is down. Not too bad anyway.

The other one is. The vertical blanking gate Zener does NOT connect from the vertical output collector to the

+420-volt boost! I'll admit that if you do not examine the schematic very closely, it LOOKS as if it does! The anode of this Zener goes to the vertical output collector, and the cathode goes to the emitter of the video output, through a 15K resistor. Change it; probably blown up.

NO SOUND FROM AMP WITH GUITAR

My son is trying to use an electric guitar he just got on my stereo amplifier. However, we get no sound from the Auxiliary or Tape inputs. The guitar is OK; we checked it on a guitar amplifier. Why can't we get sound from the stereo?—E.P., Philadelphia, PA.

For a ballpark guess, the guitar pickup doesn't have quite enough output to drive the stereo amplifier input. The voltage output of these is very low. You can probably get better results by adding a small preamp stage. Your stereo amplifier has plenty of power output, but may not have enough voltage gain in the early stages. Phono pickups and tape decks usually have a fairly high signal output, and these will drive it.

RASTER WITH DEAD DAMPER TUBE?

Here's one for you, Swami! In an old G-E, the raster was about half width and folded over very badly in the middle. Looking around, I found the damper tube completely dead! New damper tube fixed it. Here's the question: How can this happen?—L.C., Mena, AR.

That's a good question and I wish you hadn't asked. The only thing I can think of is that the damper tube had a dead heater, but also had a very good plate-to-cathode short! This would be necessary so that you could at least get B+ voltage on to the horizontal-output tube. The loss of any "damping" action would cause the severe foldover, and the loss of boost would reduce the width. (If you want the truth, I have never seen this one at all, but I'll believe anything.)

LOSS OF HIGH CHANNELS

I've a peculiar condition in an Admiral tuner. We get Channels 2, 4, 5 and 6 on the low band, and 7 and 11 on the high band. Low-band stations are pretty good, but the high-band stations are weak; in fact, it won't even get Channel 11. I tried a new 4GS7 mixer tube, but it didn't help. Tried a 5LJ8 which was given as a substitute, same thing. What is?—R.M., Houston, TX.

The most likely thing for this is a load resistor on the oscillator plate which has gone away up in value. A previous mixer tube with a short can cause this. Take a resistance reading from the B+ terminal on the tuner to the oscillator

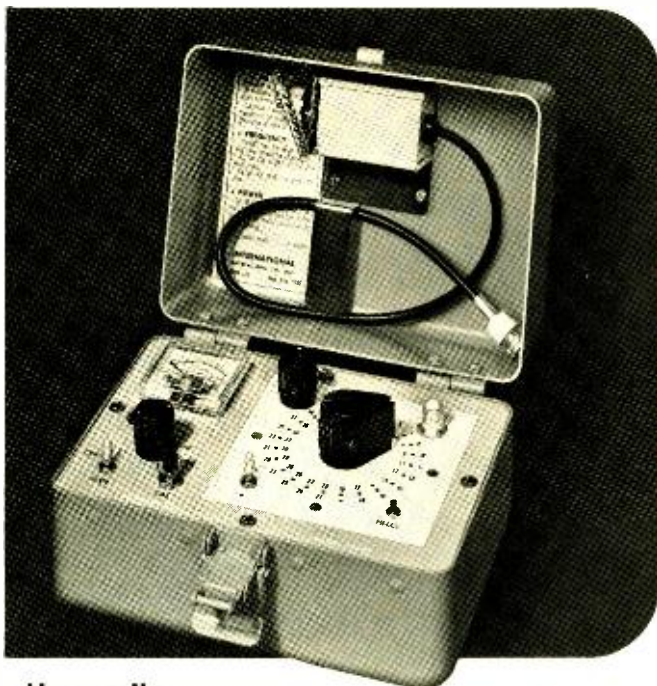
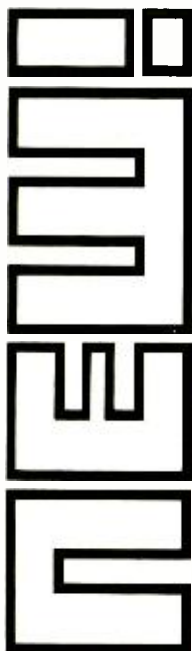

International's 6024B 40 Channel CB Frequency Meter

- Secondary Frequency Standard
- Signal Generator
- Power Meter

The 6024B provides three test instruments in one convenient case for professional servicing on all makes of Citizens Radio transceivers.

1. Secondary Frequency Standard, 26.965 to 27.405 MHz, and 27.235 to 27.405 MHz. Counter circuit zero to 2500 Hz.
2. Signal Generator 26.965 to 27.405 MHz.
3. Dummy Load/Power Meter, up to 5 watts.

Complete with connecting cable, dummy load, rechargeable battery and charger.

\$425.

Cat. No. 035311

International Crystals are available from 70 KHz to 160 MHz.

Write for information.
ICM
M/S Dept. P.O. Box 32497
Oklahoma City, Okla. 73132

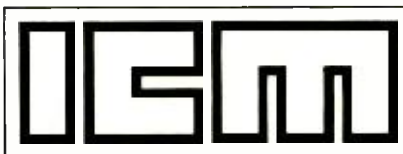

INTERNATIONAL CRYSTAL MFG. CO., INC.
10 North Lee / Oklahoma City, Okla. 73102

CIRCLE 39 ON FREE INFORMATION CARD

plate pin on the tube socket; you can do this from the top. If this resistor is far higher than it should be, replace it. Hint; you can usually clip the leads and tack the new one in. This is much easier than trying to get the ends out of the switch lugs!

WHAT'S THE CHASSIS NUMBER?

I need a schematic on this Emerson. All of the labels and markings have disappeared.—M.H. Maple Shade, NJ.

Service Ed.: "Send me a tube layout and any part numbers you can find".

M.H.: OK, here. Only part number I can find is 294-6631 on the yoke; also "70841", but I believe it's a patent number or something.

Service Ed.: Nope; that's the part number for the deflection yoke! We're so lucky we stunk. Emerson used this yoke in only *one* model, which is a Chassis 120837/839/840. etc., etc., in Sams Photofact Folder 838-2! Tube layout, etc., all agrees with your sketch.

BALLAST TUBE FOR OLD RADIO

I've got an old radio I want to fix. Uses 25L6-6SK7-6SQ7-6J5-25Z6 and a BL42D. What the heck is a BL42D? It is an odd looking thing, all metal.—B.F., Chicago, IL.

A BL42D is a "ballast tube"; it is just

a heavy duty wirewound resistor mounted in a can on a tube base. The "42" in the type number stands for the voltage drop across it. Add up the heater voltages of the tubes, and subtract it from 110 (which was the line voltage used at that time) and you'll get 42 volts.

This comes out as something like 140 ohms. Your heater current is 300 mA. Use at least a 10- or 20-watt resistor. 140 ohms is an oddball size so use 150 ohms. You can use a little more resistance since line voltages are higher now.

INTERMITTENT VIDEO

Thanks for your suggestions on my problems with a CTC-25 RCA. The video was intermittent; horizontal lines, flashes, complete picture fade and so on. You said "Check the ground points on the PC board." I looked at all of them and resoldered the ones that didn't look good. No help. So, I got out some solder lugs, nuts and bolts, and I *grounded* those points!

That did it. The problems all went away and haven't come back!

Persistence and perspiration all help. Thanks to Wes Terry, Carlsbad, CA.)

INTERMITTENT WIPEOUT OF 6JE6'S

This RCA CTC-38 chassis has a bad

habit of wiping out the 6JE6 horizontal-output tube at odd intervals! Most of the time it comes on and plays perfectly, but every so often it will blow the 6JE6 tube! I've been all over it and I can't find what's doing this. No smoke, no smell, no nothing.—A.S., Gardena, CA.

This evidently is not an intermittent short. The most likely cause would be a horizontal oscillator stage that is intermittent. If the oscillator doesn't start, you will lose the 6JE6. Try tapping, and bending the PC board around this stage; bad solder joints are a common cause.

(Feedback: That was it! Bad solder joint on the coupling capacitor from horizontal oscillator to horizontal output stage!)

CONVERT TV TO SCOPE?

I've got a curve tracer and I need a scope to work with it. Can I convert a portable TV to do this?—J.M., Bristol, TN.

There is a way of converting old TV's for scopes, but you'd probably be better off to use a regular type! The scope bandwidth has a good deal to do with the curve-tracer patterns! Look for a fairly good "previously-owned" scope, and this might do very well. Check a few known good transistors and you'll get an idea of what the patterns should look like. **R-E**



Stereo Preamp

Would you believe a high quality preamp and control center for less than \$75.00?? Well it's true. With a few hours work you can assemble our #198 preamp kit and have a unit equal to, or superior to products costing three, or four times this amount. Our kit features push-button tone controls, and extremely low distortion gain modules. Discrete transistors are used for lowest noise and distortion—no cheap IC's in this unit. Self contained 110 Volt power supply and wood grain finished cabinet.

SPECIFICATIONS

- Sensitivity 2.0 Mv. for 1.0 Volt Output
- Maximum Output. 5.0 Volts RMS
- Freq. Response ± 1 Db 10 Hz to 100K Hz.
- Distortion. Less than .05% Harmonic or IM
- Noise and Hum More than 65 Db down

198 Preamp Kit \$74.50 PPD

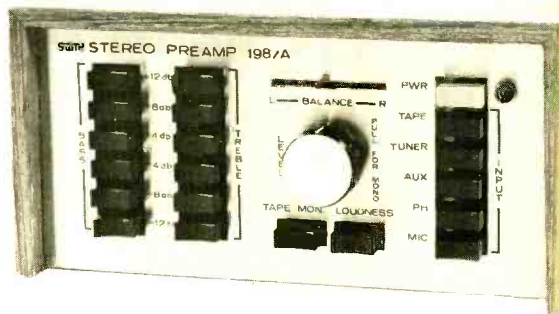

Southwest Technical Products Corp.
219 W. Rhapsody, Dept. FM
San Antonio, Texas 78216

CIRCLE 54 ON FREE INFORMATION CARD

Don't Get Caught With Your

MODULES DOWN

Increase Your Profits By Utilizing
Our Module Rebuilding Program

Consider these features!

- **Original Parts.** We use ONLY original parts. Brands we rebuild include Magnavox, Admiral, GE, Montgomery Ward, Quasar, RCA, Zenith and others.
- **Quality.** Only professionally trained technicians will handle your modules. All modules are tested, temperature cycled, retested and airtested.
- **Protective Packaging.** Rebuilt modules are returned to you in polyethylene skin packaging for protection during shipping and storage.
- **Fast Service.** Quick, reliable service is our tradition.
- **One Year Warranty.** One year limited warranty on workmanship and parts.

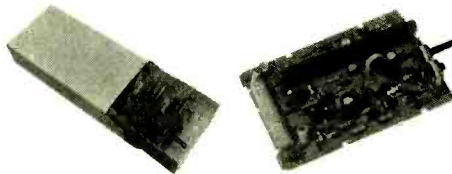

PTS ELECTRONICS, INC.

P.O. Box 272 Bloomington, IN 47401 812-824-9331

OR, check the white pages for the location of the PTS branch nearest you.

CIRCLE 56 ON FREE INFORMATION CARD

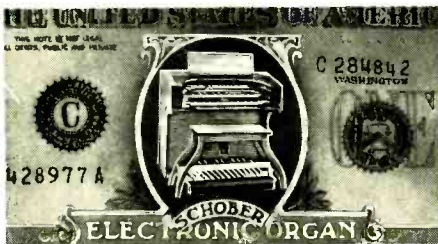

You can build a better organ than you can buy!

A magnificent Schober Electronic Organ

What a marvelous way to put your special talents to work! With our Schober Electronic Organ Kits and your skill, you can build yourself some very special satisfaction, and a lifetime of great music!

Schober Organs are literally far superior to comparably-priced "ready-made" units. You could actually pay twice as much and get no better organ... and miss the fun of assembling it yourself. A PC board at a time, component by component, you'll assemble your own "king of instruments." And when you're done, you'll wish there was more to do. And there is! For then, Schober will help you learn to play, even if you've never played a note before!

Schober Organ Kits range from \$650 to \$2850, and you can purchase in sections to spread costs out... or have two-year time payments.

Just send the coupon for the fascinating Schober color catalog (or enclose \$1 for a record that lets you hear as well as see Schober quality.)

The Schober Organ Corp., Dept. RE-159
43 West 61st Street, New York, N.Y. 10023

- Please send me Schober Organ Catalog.
- Enclosed please find \$1.00 for 12-inch L P record of Schober Organ music

NAME _____

ADDRESS _____

CITY _____ STATE _____ ZIP _____

CIRCLE 65 ON FREE INFORMATION CARD

Want to cut out a career as a two-way radio technician?

MTI offers the only training for professional FM two-way radio available. Qualified technicians are employed in government, industry, and public service. But training is your key.

You could cut out a career as a two-way radio technician by cutting out this coupon. We'll send you information on how you can learn more about this specialized field, at home.

Name _____

Address _____

City/State/Zip _____

I am a veteran or serviceman on active duty. **B B 3**



formerly

MOTOROLA TRAINING INSTITUTE

College Hill, Summerdale, Pennsylvania 17093

CIRCLE 22 ON FREE INFORMATION CARD

R-E TESTS BIGSTON

continued from page 74

cassette decks on which we have used it as a reference tape.

Judging from the very low distortion figures obtained with both varieties of tape, we suspect that the people at Bigston have set their bias too high for both standard and CrO₂ tapes. A recording level of +8 dB was reached before 3% total harmonic distortion was recorded during playback measurements and, while we certainly are in favor of good "headroom" in a cassette deck, we suspect that backing off on the bias a bit would improve frequency response. Even if the bias reduction resulted in a reduced 3% THD point for this deck to a record level of say +4 or +5 dB, we would have had much higher praise for the deck. All of which goes to prove once more how inter-related the three important tape specifications of THD, frequency response and signal-to-noise level are. If the settings of bias on this deck are typical of all production units of this model (and they well may not be), we would urge Bigston's engineers to reconsider those settings at once.

Use and listening tests

Transport action and control functions were amazingly smooth for a deck priced this low and after a few moments of use we were thoroughly familiar with the control layout. Not mentioned earlier is another innovative feature not found on decks in this class. If both the REWIND REVIEW and PLAY button are depressed simultaneously, a given tape being played will come to its end and then the PLAY button will automatically spring up (thanks to the automatic end-of-play stop feature), at which time the REWIND button takes over and automatically rewinds the tape at high speed to its starting point. With so many fine features going for it, we were distressed at the absence of highs during playback of sample musical material that we recorded. Our product analysis and summary will be found in Table II. **R-E**

COLOR TV '77

continued from page 57

pulses on the diode cathodes back-bias their junctions, allowing their anodes as well as the base and emitter of the corresponding transistor to rise.

Transistors Q41 and Q42 act as peak detectors, since they are emitter followers with high current capability in one direction. Emitter-connected capacitors C42 and C41 are the detector storage elements.

Capacitor C42 charges to a voltage dependent on the amplitude of the chroma

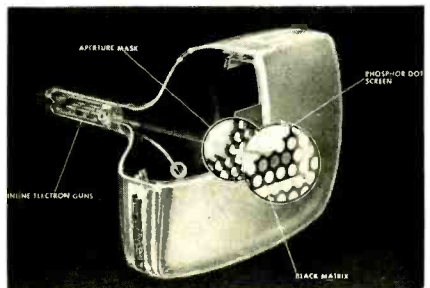

THE GENERAL ELECTRIC 25-inch in-line color picture tube.

signal during the 35-microsecond black reference interval. Capacitor C41 charges during the 15-microsecond chroma reference pulse. One of the four op-amps in IC60, an LM3900, is connected differentially to the two detector outputs. The output of the amplifier is filtered by R48, C48 and R49, and is proportional to the error between the two detected signals.

Selecting the VIR feature with the front-panel control substitutes the filtered output of the op-amp for the DC voltage on the slider of the manual tint control. Variations between the chroma tint and what the VIR signal says it should be is automatically corrected in closed-loop fashion.

GTE Sylvania

The 1977 Sylvania color line includes the carryover GT-Matic II E40 chassis in 21- and 25-inch models, the varactor-tuned E41 and E42 19- and 25-inch sets, and the E20 and E21 17- and 19-inch models. Continuation of the countdown vertical synchronization system remains unique to the GT-Matic receivers.

Seven IC's are used in the high-end GT-Matic II's. They feature an electronically regulated power-supply, low B+ short protection and horizontal shutdown circuits. Three circuit modules plug into the chassis. The IF module contains the power supply minus the transformer, the video IF and detector, the tuner AFC, and the sound IF, audio detector and power amplifier.

The video chroma module contains the chroma processor, the 3.58-MHz CW regenerator and control, video processing and blanking, and the color drive circuits. Vertical and horizontal drive and sweep systems, the pincushion circuitry and the Boost B+ power-supply are all on the deflection module. The remaining heavy parts, including the power transformer and filter, horizontal transformer, and tripler, and heat sinking for the B+ regulator and horizontal output transistor, mount on the main chassis.

All IC's and transistors plug in for serviceability. The receiver is loaded with safety features for protection against X-ray radiation and fire. Contributing to fire protection are the power-supply short circuit sensing circuits, the horizontal shutdown system, UL rated self-extinguishing wire, and a mylar insulated and epoxy encapsulated high-voltage transformer. X-ray protection components are the horizontal shutdown device, the high-voltage tripler and the strontium-90 softened CRT glass.

The varactor E41 and E42 receivers use upgraded E11 and E12 chassis. Single-knob control of the varactor tuners make VHF, UHF, and remote control tuning equal. Mechanical memory tuning centers around a 21-pot turret tuner that uses a regulated 33-volt Zener supply as the reference supply. Bandswitching applies power only to the VHF or UHF tuner at any time. The slider on the potentiometers feed a PNP-NPN dual emitter-follower circuit that buffers the tuner from the pots. The voltages of the two oppositely poled base-to-emitter junctions tend to cancel.

These sets use a constant voltage ferroresonant transformer for supply regulation.

A special retrace capacitor design prevents an increase in high voltage due to opens or shorts in the capacitor. Normally either failure would shorten the flyback time and

increase the 2nd anode voltage. Figure 5 shows the four-legged arrangement. Each of the two capacitor foils act as jumpers connecting the horizontal output transistor to

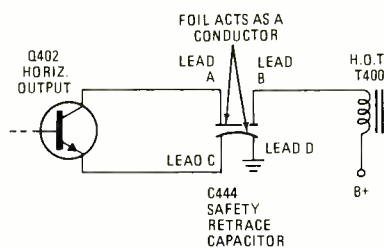
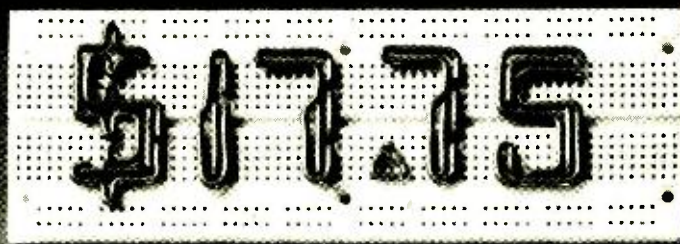

FIG. 5—SAFETY RETRACE CAPACITOR acts as fuse in Sylvania E41, E42 chassis.

the output transformer and to ground. If any connection opens, the output transformer is disconnected and the circuit is disabled. Shorts in the capacitor divert the current around the output transistor which shuts everything down.

The regulated supply in the E20 and E21 chassis uses a current sensing resistor to turn on a current limiter transistor when currents exceed 1.5 A. An SCR shuts off the drive pulses to the horizontal driver and holds the horizontal output transistor off.

Due to differences in the chromaticity coordinates of today's picture tubes and the NTSC chromaticity specifications, color errors result in straight inverse NTSC decoding. Decoding in the E20 and E21 have been modified to minimize these errors. R-E



Here's your chance to get started in solderless breadboarding and save in the process. Buy our SK-10 socket above for \$17.75 and we'll also give you our SK-20 socket as a bonus. Not only that, but if the SK-10 doesn't live up to your expectations, return it for a full refund and keep the SK-20 for your trouble.

E&L sockets are the finest made in the industry and have a life of over 10,000 insertions. Integrated circuits and dis-

crete components insert directly without adapters. And all interconnections are made with 20 gauge solid conductor wire. Get started now. E&L solderless breadboarding sockets are available through local participating computer stores. These

stores also carry E&L's full line of breadboarding and micro-computer equipment as well as our line of BUGBOOKS®. Stop in today and start going solderless.

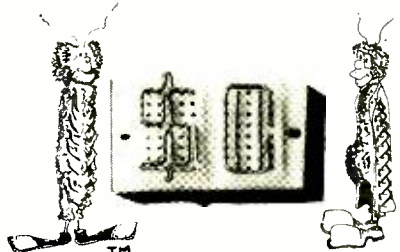

E&L INSTRUMENTS, INC.

61 First Street, Derby, Conn. 06418
(203) 735-8774 Telex No. 96 3536

Dealer inquiries invited.

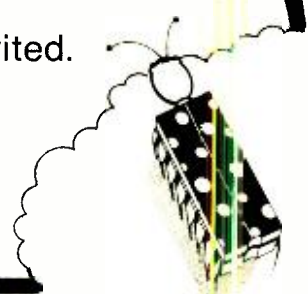

Empire's Blueprint For Better Listening

No matter what system you own, a new Empire phono cartridge is certain to improve its performance.

The advantages of Empire are threefold.

One, your records will last longer. Unlike other magnetic cartridges, Empire's moving iron design allows our diamond stylus to float free of its magnets and coils. This imposes much less weight on the record surface and insures longer record life.

Two, you get better separation. The small, hollow iron armature we use allows for a tighter fit in its positioning among the poles. So, even the most minute movement is accurately reproduced to give you the space and depth of the original recording.

Three, Empire uses 4 poles, 4 coils, and 3 magnets (more than any other cartridge) for better balance and hum rejection.

The end result is great listening. Audit on one for yourself or write for our free brochure, "How To Get The Most Out Of Your Records." After you compare our performance specifications we think you'll agree that, for the money, you can't do better than Empire.



EMPIRE

Already your system sounds better.

Empire Scientific Corp.
Garden City, New York 11530

CAR CLOCK

continued from page 63

reaching the setting that causes it to flash at 60 flashes-per-minute.

If C4 is adjusted to provide the 50-Hz input to the clock up from 30 Hz, the oscillator may not begin oscillations at 100 kHz whenever power is initially applied to the clock. This is true even if a counter is used to adjust the frequency.

Display current calibration

During display-current calibration, the time should be set to 10:08 or 10:09 for optimum results. This can be accomplished by manipulating the FAST SET and SLOW SET switches.

The BIAS potentiometer (R10) and the DARK ADJUST potentiometer (R9) must be set to values that allow maximum safe current to flow through the display when maximum ambient light is striking its face. In addition, the display current must fall to a value that will yield the desired display intensity for night-time driving. Therefore, the display current must be monitored with an ammeter between the display power Digi-Klip located on the main board and the display power edge connector located on the display board.

During LED display calibration, the nuts that hold the bezel to the display board should be loose enough to allow easy access to the photoresistor. However, during the incandescent display calibration, the bezel must be secure so that the chimney of the photoresistor is flush against the viewing screen; this will eliminate the problem of light reaching the photoresistor via the display itself.

For this reason the calibration procedures for the two types of displays are different. Calibration for the LED display will be discussed first.

LED display calibration

With R9 and R10 set at minimum resistance, and the viewing screen in place, allow the maximum expected ambient light to strike the display and the photoresistor through the viewing screen.

Increase the resistance of R10 until the display current, as read on the ammeter, is about 210-220 mA. The display should be visible, but not flashing to indicate a power failure.

After a 5-minute warm-up period, adjust R10 for a display current of 300-310 mA. Allow another 2-minute warm-up period; adjust the potentiometer, if necessary, to keep the display current at or below 310 mA. Set the time to 10:08 or 10:09 and reset R10 to 300-310 mA, if necessary.

Remove the viewing screen or bezel, and cover the photoresistor with black electrical tape. With the time set to 10:08 or 10:09, increase the resistance of R9 until the display current is about 20 mA. In bright light, the display will not seem visible, however, it will be about right for nighttime viewing.

Remove the black tape from the photoresistor, replace the viewing screen, and apply maximum expected ambient light to the display. Readjust R10 for a display current of 300-310 mA with the time set to 10:08.

Repeat the dark adjustment and the light adjustment until the display current is about 20 mA when the photoresistor is covered with black tape, and 300-310 mA with the black

tape removed, the viewing screen in place, and maximum expected ambient light striking the display.

The 20-mA dark display current is an approximation only; the display should be adjusted for final desired intensity under actual conditions. During all display current adjustments, the time should be set to 10:08, if possible. After adjustments are completed, the display brightness should be sensitive to a hand passed in front of the photoresistor. If absolutely necessary, the maximum permissible display current is 315 mA. However, some allowance should be made for seasonal changes in the weather. With the display disabled, maximum current drawn by the clock will be about 15 mA; with displays enabled, about 325 mA.

Incandescent display calibration

With R9 and R10 set at minimum resistance, the viewing screen in place, and the chimney of the photoresistor flush against the viewing screen, allow the maximum expected ambient light to strike the display and the photoresistor through the viewing screen.

Increase the resistance of R10 until the display current is about 200 mA. Allow a 2-minute warm-up period, then set the time to 10:08 or 10:09.

Readjust R10 for a display current of about 290 mA. Remove the viewing screen and cover the photoresistor with black tape. Then increase the resistance of R9 until the display current is about 100 mA.

Remove the black tape from the photoresistor, replace the viewing screen, and allow maximum expected ambient light to strike the display. The display current should rise to about 290 mA if the time is set for 10:08.

Once again, the viewing screen should be removed and the photoresistor covered with black tape to make sure that the display current will fall to about 100 mA when the photoresistor is fully dark.

If this operation is not correct repeat the above adjustments, but adjust R10 to about 285 mA with the time set at 10:08. Continue in this manner, reducing the initial light current in steps of 5 mA, if necessary, until the maximum display current (not to exceed 290 mA) can be obtained under maximum ambient light. However, the display current should fall to about 100 mA when the photoresistor is covered with black tape.

With the incandescent displays, only one adjustment of the BIAS and DARK ADJUST potentiometers should be necessary; the additional steps are simply given in case they are needed.

With the display disabled, maximum current drawn will be about 15 mA; with displays enabled, about 305 mA. **R-E**



"I hardly think it's proper, to have my alma mater, scavenging upon my clientele."

RESISTOR BURNUP

I've been very confused trying to get this Kenwood amplifier straightened out. There's a 68-ohm resistor in the left channel output that keeps burning up. What can I do to prevent this?—W.Q., Granada Hills, CA.

For one thing, check the *resting* current in both channels. This is the output stage current with no signal at all. It should be the same in both channels and should be fairly small, say about 20 mA ballpark. It will increase as the volume is turned up but should still be about the same in both.

(Feedback: That did it! One channel read about 15 mA, the other read over 100 mA resting current! This was the one that was blowing the 68-ohm resistor. Further checking showed up a couple of resistors in the bias network that had changed in value. I cross-checked against the same resistors in the other channel. Thanks.)

WHY DOESN'T THE RASTER GO OUT?

There is raster and sound on this CTC-39XA RCA but no picture. The plate voltage is high on the 12HG7 video-output tube but the cathode voltage is zero. Screen voltage is high too. In fact, I can pull this tube with no effect. Why does the raster stay on? I thought it should go out!—T.H., Pontiac, MI.

It ought to. In either case (zero cathode voltage indicating no plate current, or tube out), the plate voltage should rise to the supply level. This bias change on the picture tube should cut it off. Now: let us heat up the analyzing iron and see.

One: It sounds to me as if your controls are all honked up! See if all three screen controls on the picture tube aren't turned full on. This will raise the cutoff so that you can get a raster.

Two: Check continuity in the 12HG7 cathode circuit: the contrast control may be open. Also, look to see if this tube is LIT! This booby-trapped me in a case with the same symptoms!

■ MATHEMATICS ■ ELECTRONICS

■ ENGINEERING MATHEMATICS

■ ADVANCED MATHEMATICS

■ ADVANCED ENGINEERING MATHEMATICS

These unusual courses are the result of many years of research and teaching by the President of INDIANA HOME STUDY INSTITUTE, who has *personally* lectured in the classroom to *thousands* from all walks of life on mathematics, electrical and electronic engineering.

- You must see these lessons to appreciate them!
- NOW you can master mathematics and electronics and actually *enjoy* doing it!
- WE ARE THIS SURE:—you order your lessons on a money-back guarantee.

WRITE TODAY for more information and your outline of courses. You have everything to gain and nothing to lose!

LICENSED BY THE STATE BOARD OF INDEPENDENT POST-SECONDARY VOCATIONAL, TECHNICAL, TRADE AND BUSINESS SCHOOLS.

THE INDIANA HOME STUDY INSTITUTE
EASTERN DIVISION
P.O. BOX 1189
PANAMA CITY, FLA. 32401

CIRCLE 26 ON FREE INFORMATION CARD

ONE RIG DOES IT ALL!

Tube and Solid State

THE UNIVERSAL PJS-298

33KV LEADED GLASS 19" CRT

EIA recommended to protect against dangerous X-radiation

A MUST FOR TODAY'S SERVICING

ACCESSORIES INCLUDE:

- CRT 90° Extension
- Yoke Extension
- Transverter
- Convergence Load
- Universal Yoke
- Convergence Assembly
- Blue Later Assembly
- Anode Extension

SOLD THROUGH DISTRIBUTORS ONLY

BUILT-IN SPEAKERS

Easy audio checking

40 KV METER

50aU sensitivity monitoring

FRONT CONNECTORS

Convenient cable plug-in

OBSOLETE PROOF

Plug in modules for up-dating

\$298.98 VALUE

SPECIAL INTRODUCTORY OFFER

\$229.95

COMPLETE WITH CRT

TeleMatic

2849 FULTON ST., BROOKLYN, NY 11207
PHONE: (212) 827-1500

PLEASE SEND ME MORE INFORMATION	P-2
NAME _____	
ADDRESS _____	
CITY _____ STATE _____ ZIP _____	

CIRCLE 73 ON FREE INFORMATION CARD

Herb Laney's a tough-minded optimist. How about you?

Herb takes his future seriously. Without worrying about it. He knows his CIE training is giving him valuable skills in electronics. Skills a lot of people will be glad to pay for. And that's good reason for all the optimism in the world. How about you?

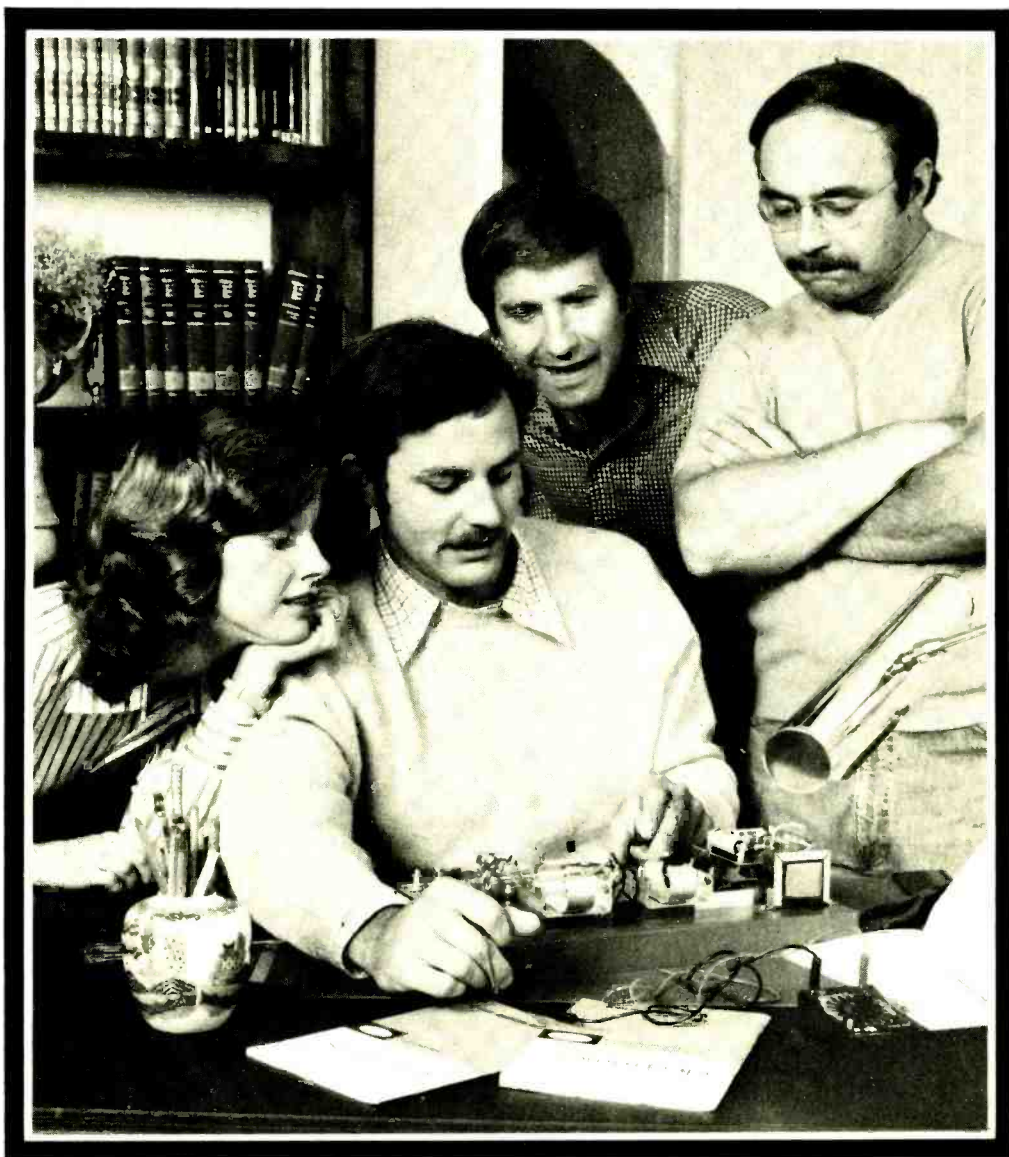

Learning new skills isn't something you just breeze through. Especially in electronics. You've got to really *want* success if you're going to build your skills properly.

Herb knew that right from the start. But he also knew what rewards he could earn if he took some time and did it right. He knew that, in today's world, people who really *know* electronics find a lot of other people... even whole industries... looking for their help.

How about you? How much do you want that thrilling feeling of success... of being in demand? Enough to work for it?

Why it pays to build skills and know-how.

One of the things that got Herb interested in electronics is that electronics seems to be something just about *everybody* needs. Almost everywhere you look these days — in a business office... a manufacturing plant... a department store... a doctor's office... a college... even your own home you'll find all kinds of electronic devices.

That spelled "opportunity" to Herb. Plus he liked the idea of having a set of skills that might lead to jobs in places as different as a TV station... a hospital... an airport... a petroleum refinery.

But what Herb liked *most* about electronics is that it's just plain *interesting*. Even though it takes time and effort to learn, the subject is so fascinating it *almost* doesn't seem like "studying" at all!

How CIE keeps you interested.

CIE's unique study methods do a lot to *keep* you interested. Since electronics starts with ideas... with principles... CIE's Auto-programmed Lessons help you get

the idea — at your own most comfortable pace. They break the subject into bite-size chunks so you explore each principle, step by step, until you understand it thoroughly and completely. *Then* you start to use it.

How CIE helps you turn ideas into reality.

Depending on the program you choose, CIE helps you apply the principles you learn in a number of different ways.

If you're a beginner, you'll likely start with CIE's Experimental Electronics Laboratory. With this fascinating workbench lab, you actually perform over 200 experiments to help you grasp the basics! Plus you use a 3-in-1 precision Multimeter to learn testing, checking, and analyzing.

In some programs, you build your own 5MHz triggered-sweep, solid-state oscilloscope — and learn how to "read" waveform patterns... how to "lock them in" for closer study... how to understand and interpret what they tell you.

To help you develop practical, skill-building knowledge you then receive a Zenith 19" diagonal



solid-state color TV featuring nine removable modules. You learn how to trace signal flow... how to detect and locate malfunctions... how to restore perfect operating standards.

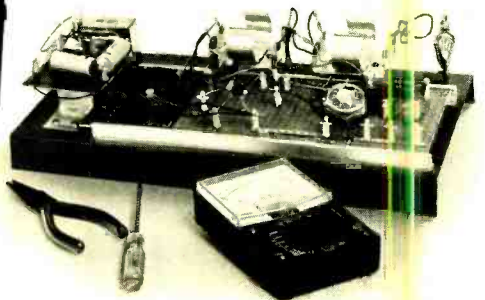

What to do first.

Get all the facts. Send for CIE's FREE school catalog and career information package TODAY. Check *all* the CIE programs — and see which one's right for you. Do it now.

Why it's important to get your FCC License.

More than half of CIE's courses prepare you for the FCC License exam. In fact, based on continuing surveys, better than 4 out of 5 CIE graduates who take the exam get their License!

That's important. For some jobs in electronics, you *must* have your FCC License. For others, employers often consider it a mark in your favor. It's *government-certified proof* of specific knowledge and skills!

Free catalog!

Mail the card. If it's gone, cut out and mail the coupon. If you prefer to write, mention the name of this magazine. We'll send you a copy of CIE's FREE school catalog — plus a complete package of independent home study information! For your convenience, we'll try to have a representative call to help you with course selection. Mail the card or coupon... or write: CIE, 1776 East 17th Street, Cleveland, Ohio 44114.



CIE Cleveland Institute of Electronics, Inc.
1776 East 17th Street, Cleveland, Ohio 44114

Accredited Member National Home Study Council

YES... I want to succeed in electronics. Send me my FREE CIE school catalog — including details about all electronics courses — plus my FREE package of home study information! RE-03

NAME _____
ADDRESS _____ (please print) APT. _____
CITY _____
STATE _____ ZIP _____
AGE _____ PHONE (area code) _____

Check box for G.I. Bill information: Veteran Active Duty

Mail today!

new products

More information on new products is available from the manufacturers of items identified by a Free Information number. Free Information Card follows page 106.

S/R F METERS. Signal strength and relative power output are easily read with these units. The base version is in a 3 × 7 × 4-inch case;



the mobile version in a 3 × 4 × 5-inch case. Both units come with a 5-foot shielded cable and a standard phone plug—Kris, Inc., Pioneer Rd., Cedarburg, WI 53012

CIRCLE 101 ON FREE INFORMATION CARD

CB HEADSET ADAPTER, model CB-88 consists of an eyeglass adapter and a CB-88 lightweight headset. The adapter is an eyeglass clip onto which either of the eyeglass temples is inserted. The adapter is held firmly in place with a setscrew. The headset weighs less than 3 ounces. When receiving and transmitting ele-



ments are used with the eyeglass, making use of the headband unnecessary, the weight is further reduced. The unit includes a noise-cancelling power mike and is mounted on a pivoting boom. The push-to-talk switch is equipped with a clothing clip. The unit is priced for less than \$70.00—Telex Communications, Inc., Minneapolis, MN 55420

CIRCLE 103 ON FREE INFORMATION CARD

CB ANTENNA DISGUISE. The Little Fooler AM/FM/CB antenna deters theft simply because it doesn't look like a CB antenna. It looks like an ordinary three-section telescopic antenna.



The antenna transmits and receives CB simultaneously with AM and FM. It covers all CB channels. VSWR of 1.2:1 is claimed on any of the 40 channels—Anixter Bros., Inc., 4711 Golf Road, One Concourse Plaza, Skokie, IL 60076

CIRCLE 104 ON FREE INFORMATION CARD

CB ANTENNAS. Four styles of fiberglass antennas offering a complete selection of top-, center- and base-loaded models. They are available individually, in kits with mounts, or twin antenna kits with harnesses featuring GC Co-Phase Mixer-Balun Circuitry—GC Electronics,



Div. of Hydrometals, Inc., 400 S. Wyman, Rockford, IL

CIRCLE 105 ON FREE INFORMATION CARD

CB ANALYZER, model GN-1375B is AC/battery-powered portable instrument for testing performance and troubleshooting CB transceivers

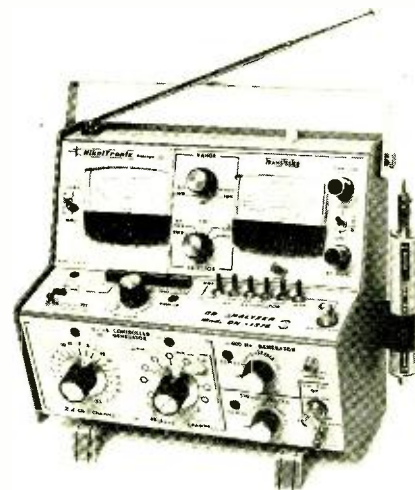

and other communication products. Comes complete with test cables, probe, battery pack module, regulated power supply-charger, AC cord and instruction manual. The unit uses crystal-controlled RF oscillators to provide laboratory-grade performance of high accuracy, stability, and reliability. Also, it is equipped with an RF/AF signal tracer, and RF wattmeter, dummy load, SWR meter, relative field-strength monitor and % of modulation meter.—Nikoltronix Electronic Engineering Co., 2437 W. Peterson Ave., Chicago, IL 60659

CIRCLE 106 ON FREE INFORMATION CARD

CB ANTENNA MOUNT. Quick-disconnect version for automobile and marine applications is easily removed with a simple flip of the wrist. Designed with a holding pressure of 300 pounds



in the locked position, it is adaptable for use on automobile mirrors and luggage racks, or boat rails. It can be adjusted for 1/2 inch to 1 inch tubing—Midwest Electronics, 229 Fassett St., Toledo, OH 43605

CIRCLE 107 ON FREE INFORMATION CARD

6 Digit LED Clock Kit - 12/24 hr.

\$995 QTY. 12
ea. OR MORE

\$1095 QTY. 6-11
ea.

\$1195 QTY. 1-5
ea.

- KIT INCLUDES**
- INSTRUCTIONS
 - QUALITY COMPONENTS
 - 50 or 60 Hz OPERATION
 - 12 or 24 HR OPERATION

6-LED Readouts (FND-359 Red, com. cathode)
1-MM5314 Clock Chip (24 pin)
13-Transistors
3-Switches
5-Capacitors
5-Diodes
9-Resistors
24-Molex pins for IC socket

LARGE .4" DIGITS!
ORDER KIT #850-4
AN INCREDIBLE VALUE!

"Kit #850-4 will furnish a complete set of clock components as listed. The only additional items required are a 7-12 VAC transformer, a circuit board and a cabinet, if desired."

Printed Circuit Board for kit # 850-4 (etched & drilled fiberglass) \$2.95
Mini-Brite Red LED's (for colon in clock display) pkg. of 5 1.00
Molded Plug Transformer 115/10 VAC (with cord) 2.50
NOTE: Entire Clock may be assembled on one PC Board or Board may be cut to remote display.
Kit # 850-4 will fit Plexiglas Cabinet II.

6 Digit-LED Clock-Calendar-Alarm Kit

This is a complete, top of the line, Kit for the person that wants the best. Some of the many features and options are: 12/24 time, 28-30-31 day calendar, alternates time (8 sec) and date (2 sec) or can display time only and date on demand, 24 hr alarm - 10 minute snooze, alarm set indicator, 50/60 HZ. line operation or use with Xtal time base (#TB-1), built in OSC for battery back-up / AC failure, Aux. timer, CHOICE OF DIGITS.

- Kit #7001B 6 - .4" Digits \$39.95
- Kit #7001C 4 - .6" Digits & 2-. " [Seconds] \$42.95
- Kit #7001X 6 - .6" Digits \$45.95

Kits are complete (less cabinet) including PC boards, power supply, IC socket, 9 switches, 16 transistors and all parts required for above features and options [All #7001 Kits Will Fit Cabinet I]

PRINTED CIRCUIT BOARDS for CT-7001 Kits sold separately with assembly info. PC Boards are drilled Fiberglass, solder plated and screened with component layout. Specify for # 7001B or # 7001C (Set of 2) \$7.95

JUMBO DIGIT CLOCK KIT

A complete Kit (less Cabinet) featuring: six 5" digits, MM5314 IC, 12/24 Hr. time, 50/60 HZ., Plug-Transformer, Line Cord, Switches, and all Parts.
[Idea! Fit in Cabinet II]
Kit #5314-5 **\$1995 2/\$38.**

JUMBO DIGIT CONVERSION KIT

Convert small digit LED clock to large 5" displays. Kit includes 6-.5" LED's, Multiplex PC Board & easy hook-up info.
Kit # JD-1CC For common Cathode
Kit # JD-1CA For common Anode **\$995 ea. 2/\$19.**

SEE THE WORKS Clock Kit

Clear Plexiglas Stand

- 6 Big 4" digits
 - 12 or 24 hr. time
 - 3 set switches (back)
 - Plug transformer
 - All parts included
- Plexiglas
Pre-cut & drilled
Size: 6" H, 4 1/4" W, 3" D

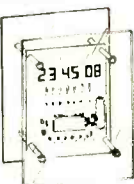

A SUPER LOOKING CLOCK!

Kit #850-4-CP **\$2350 ea. 2/\$45.**

7-SEG LED COMMON CATHODE

COLOR	HT.	DEC.	PT.	PRICE
FND-359	RED	4"	RHDP	\$.95
FND-503	RED	5"	RHDP	\$1.35
DL-750	RED	6"	LHDP	\$1.95
XAN-654	GREEN	6"	NDP	\$1.95
XAN-664	RED	6"	NDP	\$1.95

COMMON ANODE				
DL-747	RED	6"	LHDP	\$1.95
MAN-72	RED	3"	LHDP	\$1.25
XAN-81	YELLOW	3"	RHDP	\$1.75
XAN-351	GREEN	3"	RHDP	\$1.50
XAN-361	RED	3"	RHDP	\$1.50
XAN-362	RED	3"	LHDP	\$1.50
XAN-662	RED	6"	NDP	\$1.95
XAN-692	RED	6"	NDP	\$1.95

Form Inexpensive Sockets 100 for \$1.25
Reel of 1000 - \$8.50

MOLEX PINS
SOCKET

Fairchild Super Digit FND-359

4" Char. Ht. 7 segment LED RED Com. Cath. Direct pin replacement for popular FND-70
95¢ ea. 10/\$8.50
100/\$79.00

SET OF 6 FND-359 WITH MULTIPLEX PC BOARD \$6.95

25 AMP BRIDGE \$1.95 ea.
100 PIV 3/\$5.00

TELEPHONE FORMAT KEYBOARD BY Chomerics

2-1/4"x3" 5/32" thick
\$4.95
6/\$28.

SCHOTTKY	DTL	PRESCALE	EXAR	OP AMPS
TTL	330 \$.09	11C90DC \$15.95	XR 2556 \$ 1.75	3/101
74S00 \$.35	932 \$.09	95H90 9.95	XR 2567 \$ 1.95	301 TO-5
74S01 \$.40	937 \$.09	DIODES	TRANSISTORS	709 DIP
74S04 \$.55	LED DRIVERS	IN 4002 1A, 100 PIV 12/\$1.00	2N2222 TO-18 5/51.00	709 TO 5
74S05 \$.60	7447 \$.95	IN 4005 1A, 600 PIV 11/\$1.00	2N2554 TO-5 2/51.00	741 DIP
74S09 \$.55	7448 \$.95	IN 4007 1A, 1000 PIV 10/\$1.00	2N2712 TO-98 5/51.00	741 M-DIP
74S10 \$.40	75491 \$.65	RECTIFIER 2.5A, 1000 PIV 4/\$1.00	2N3115 TO-92 5/51.00	741 TO-5
74S20 \$.50	75492 \$.66	IN 914 SIL SIGNAL 20/\$1.00	2N3704 TO-92 5/51.00	747 DIP
74S22 \$.45	VOLTAGE REGULATORS	IN 4148 (1N914 Equiv.) 20/\$1.00	2N4400 TO-92 5/51.00	747 DIP
74S40 \$.45	LM 309H TO-5 \$.95	DYAC 2BV 4/\$1.00	2N4125 TO-92 5/51.00	748 DIP
74S50 \$.45	LM 309K TO-3 1.25	PLUG TRANSFORMERS	2N4249 TO-92 5/51.00	DISCRETE LED'S
74S51 \$.55	7805 TAB 95	12VAC at 150 MA \$2.50	2N4437 TO-92 5/51.00	JUMBO RED
74S64 \$.55	7812 TAB 1.25	12VAC at 500 MA 3.50	2N6027 PUT 2/51.00	12/\$1.00
74S73 1.25	7815 TAB 1.25	7 VAC at 1.75VA 2.50	2N6457 N.J.Fet 2/51.00	50/\$3.95
74S74 \$.85	7815 TO-3 1.25	LINEAR	SWITCHES	100/\$7.50
74S75 1.75	7815 TO-5 75	555 TIMER 2/\$1.00	ROCKER SPDT 6/61	12/\$1.00
74S78 1.50	7815 TO-3 1.25	556 DUAL TIMER 95	MINI-SLIDE SPDT 5/61	50/\$3.95
74S86 95	7815 TO-3 1.25	565 PLL 1.75	REG. SLIDE DPDT 6/61	100/\$7.50
74S107 95	7815 TO-5 75	566 FUNCTION GEN. 95	PUSH BUTTON N.O. 3/61	PC TRIM
74S112 95	LM340T 18 TAB 1.25	567 TONE DECODER 1.75	MINI TOGGLE SPDT \$1.30	POTS
74S113 1.40	LM340T 24 TAB 1.25	IC SOCKETS	FUNCTION TOGGLE DPDT 1.50	25K 6/61.00
74S114 95	7824 TO-3 1.25	PINS 1.24 25 100	TRANSISTOR SOCKET	4.7K 6/61.00
74S133 75	723 DIP 75	8 \$ 25 22 \$ 20	TO-5/18 GOLD PINS	SPECTROL 10K TO TURV 95c 4/\$3.00
74S134 75	723 TO-5 75	14 25 22 20	5/61.00	
74S138 1.75	DIGITAL CLOCK IC'S	16 28 25 23	NYLON WIRE TIES	
74S139 1.50	MM 5312 \$ 4.95	18 31 28 26	8" TIE WRAP 100/\$1.95	
74S151 1.95	MM 5314 3.95	24 50 45 40	4" TIE WRAP 100/\$1.75	
74S153 1.95	MM 5375 AB 3.95	28 80 55 65	MOLEX PINS	
74S155 1.95	CT-7001 7.95	40 75 70 65	REEL OF 1000 \$ 8.50	
74S157 1.80	CT-7002 13.95	COMPUTER	STRIPOF 1000 1.25	
74S158 2.50	50390 3.95	8080A CPU 19.95	MISC. PRIME IC'S	
74S174 2.50	50390 3.95	1702 E Prom 8.95	FAIRCHILD 9316 (74161) \$.95	
74S175 2.50	MM 5369 2.50	5203 E Prom 8.95	75234 DUAL CORE SENSE AMP 1.50	
74S181 1.95	XTAL	21021 1PC 1.95	MM 502H TO-5 SHIFT REG .95	
74S251 2.75	3.579545 MHZ \$ 1.95			

60 HZ. XTAL TIME BASE KIT

Will enable Digital Clock or Clock-Cal. Kits to operate from 12VDC. Uses MM5369 and 3.58MHZ XTAL. Req. 5-15VDC/2.5 MA. 1"x2" PC Board. Easy 3 wire hookup Accuracy: +/- 2 PPM
#TB-1 [adjustable]
Complete kit \$4.95 ea
Wired & Cal. \$9.95 ea

Visit Our Store at 823 S. 21st. Avenue, Hollywood, Fl.

MOBILE LED CLOCK

12 OR 24-HOUR OPERATION

12 VOLT AC or DC POWERED FOR FIXED OR MOBILE OPERATION.
SIX LARGE .4" DIGITS!

KIT OR ASSEMBLED

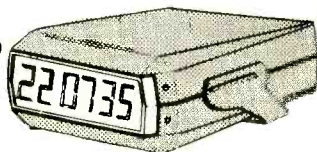

MODEL 2001

ACCURATE TIME WITH ADJUSTABLE XTAL TIME BASE

Approx. Size: 1 1/4" H x 4" W x 4 1/2" D

BATTERY BACK-UP FOR POWER FAILURE OR TRANSPORTING FROM HOUSE TO CAR ETC.

- 6 JUMBO 4" RED LED'S BEHIND RED FILTER LENS WITH CHROME RIM.
- SET TIME FROM FRONT VIA HIDDEN SWITCHES - 12/24-Hr. TIME FORMAT
- STYLISH CHARCOAL GRAY CASE OF MOLDED HIGH TEMP. PLASTIC
- BRIDGE POWER INPUT CIRCUITRY - TWO WIRE NO POLARITY HOOK-UP
- OPTIONAL CONNECTION TO BLANK DISPLAY (Use When Key Off in Car, Etc.)
- TOP QUALITY PC BOARDS & COMPONENTS - EXCELLENT INSTRUCTIONS
- MOUNTING BRACKET INCLUDED

KIT # 2001 COMPLETE KIT (Less 9V Battery) **2995** EA 3 OR MORE **\$2795** EA 115 VAC Power Pack # AC 1 **\$250** EA
ASSEMBLED UNITS W/ WIRE & TESTED (LESS 9V BATTERY) **\$3995** EA 3 OR MORE **\$3795** EA Assembled Units May Be Mixed With Kits for Qty. Price

CPU \$19.95 ea. NS8080AD

40 Pin socket
\$.50 with each 8080A!

450 ns MEMORY Fairchild 1K Ram

low, low, low power.
2102L1PC \$1.95 ea.
25-99 \$1.75 ea.
100-199 \$1.60 ea.
200 or more \$1.45 ea.

JUMBO RED LED'S 12/\$1.00 50/\$3.95

PLEXIGLAS CABINETS

Black, White or Clear Cover

Great for Clocks or any LED Digital project. Clear-Red Chassis serves as Bezel to increase contrast of digital displays.



CABINET

3" H, 6 1/4" W, 5 1/2" D

CABINET

\$6.50 ea. 2/\$12. ANY SIZE/ 2 1/2" H, 5" W, 4" D

3" x 6" x 1 1/8" RED OR GREY PLEXIGLAS FOR DIGITAL BEZELS **95¢ ea. 4/\$3**

OPTOELECTRONICS, inc.

BOX 219 • HOLLYWOOD, FLA. 33022 • (305) 921-2056



ORDER BY PHONE OR MAIL
COD ORDERS WELCOME (\$1.00 CHG.)
Orders Under \$15 Add \$1.00 Handling
Fla. Res. Please Add 4% Sales Tax.

WE PAY ALL SHIPPING IN CONTINENTAL USA - OTHERS ADD 5% (10% FOR AIRMAIL)

NEW PRODUCTS

continued from page 92

HI-FIDELITY SPEAKER SYSTEMS. The *model SP-325* is a three-way acoustic suspension speaker system featuring an 8-inch woofer with 1³/₄-pound magnet with a 1/2-inch rolled suspension cone and a 1/4-inch long-throw voice coil.

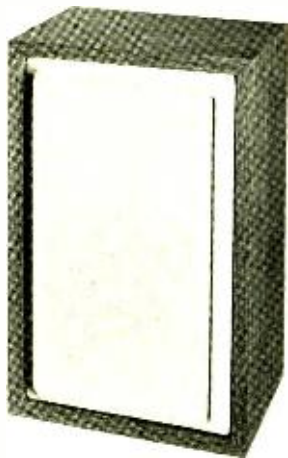

The *SP-325* also has a 3-inch mid-range speaker and a 3-inch super tweeter. Crossover frequencies at 6,000 and 9,000 Hz, frequency response is 50 to 20,000 Hz at 8 ohms, power handling capacity is 20 watts RMS with peak power 30 watts. This speaker system also features a cabinet structure, 10³/₈ by 16³/₈ by 7³/₈ inches, of oiled walnut with a laminated finish over 1/2-inch composition board. The removable grille is contrasting brown grille cloth fabric, stretched over plastic molded perforated base. The model

weighs 15 lbs. and retails for \$40.00.—**Olson Electronics**, 260 Forge St., Akron, OH 44327.

CIRCLE 87 ON FREE INFORMATION CARD

INTERFERENCE FILTERS, models AV-800, AV-811 and AV-820. If the CB transceiver is radiating harmonics of the same frequency assigned to one or more of the local TV channels, installation of the *model AV-800* low-pass filter (shown) on the transceiver should clear up the problem. If the problem is at the TV receiver

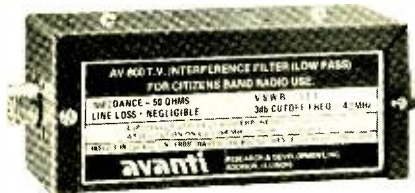

due to front-end overloading, the *model AV-811* filter on the TV lead-in should solve it. The filter lets the TV signals come through unhindered, while choking off the incoming CB signal. A third filter, *model AV-820*, used at the TV set, prevents outside CB signals from entering the TV through the AC power line.—**Avanti Research & Development, Inc.**, 340 Stewart Ave., Addison, IL 60101.

CIRCLE 88 ON FREE INFORMATION CARD

CB METER, Model 10043. is a combination power-meter and voltage standing-wave ratio bridge. The new meter measures RF output power up to 10 watts as well as providing VSWR measurements. An important feature of the meter is that it does not require a perfect impedance match to read accurately. It will read ±5% regardless of the input-output impedance match.

The meter is housed in a high-impact black plastic case. The suggested retail price is



\$88.00.—**Antenna Incorporated**, 23850 Commerce Park Road, Cleveland, OH 44122.

CIRCLE 89 ON FREE INFORMATION CARD

CB MONITOR, model CB 23, converts any AM car radio to a Citizen-band receiver. Includes a

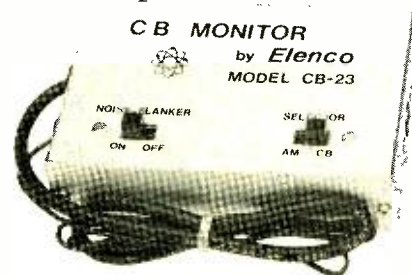

built-in noise suppression circuit using 4 transistors and 3 diodes to minimize ignition noise.



GO DIGITAL, GO DANAMETER®

(The New VOM For Today's Needs.)

- 0.25% Accuracy
- Full Overload Protection
- Really Drop-Proof
- Full One Year Battery Life



Dana Laboratories, Inc.

2401 Campus Dr, Irvine, Ca 92715, (714) 833-1234

CIRCLE 84 ON FREE INFORMATION CARD

Kleps 30

Kleps 40

Kleps 1

Kleps 10

Kleps 20

Pruf 10

Kleps 10 - 20

Kleps 30

Kleps 40

Kleps 1

Pruf 10

Clever Kleps

Test probes designed by your needs — Push to seize, push to release (all Kleps spring loaded).

Kleps 10. Boathook clamp grips wires, lugs, terminals. Accepts banana plug or bare wire lead. 4 3/4" long. **\$1.39**

Kleps 20. Same, but 7" long. **\$1.49**

Kleps 30. Completely flexible. Forked-tongue gripper. Accepts banana plug or bare lead. 6" long. **\$1.79**

Kleps 40. Completely flexible. 3-segment automatic collet firmly grips wire ends, PC-board terminals, connector pins. Accepts banana plug or plain wire. 6 1/4" long. **\$2.59**

Kleps 1. Economy Kleps for light line work (not lab quality). Meshing claws. 4 1/2" long. **\$.99**

Pruf 10. Versatile test prod. Solder connection. Molded phenolic. Doubles as scribing tool. "Bunch" pin fits banana jack. Phone tip. 5 1/2" long. **\$.89**

All in red or black - specify. (Add 50¢ postage and handling). Write for complete catalog of - test probes, plugs, sockets, connectors, earphones, headsets, miniature components.

Available through your local distributor, or write to:

RYE INDUSTRIES INC.

128 Spencer Place, Mamaroneck, N.Y. 10543
In Canada: Rye Industries (Canada) Ltd.

CIRCLE 35 ON FREE INFORMATION CARD

Can be installed in less than 2 minutes with no tools. No special antenna is needed. All 23-channels are tuned by using the regular AM radio dial with Channel-10 corresponding to the 1000 spot on the dial. Price: \$34.95.—**Elenco Electronics**, 1940 Raymond Drive, Northbrook, IL 60062.

CIRCLE 90 ON FREE INFORMATION CARD

TOOL KIT, model 39991, is a 13-piece combination nutdriver and screwdriver set packed in a see-through plastic case that also serves as a bench stand. Included are: a handle, 4" exten-



sion, 3/16" slotted, 1/4" slotted, #1 phillips, #2 phillips, 3/16" nutdriver, 7/32" nutdriver, 1/4"

nutdriver, 9/32" nutdriver, 5/16" nutdriver, 11/32" nutdriver, and 3/8" nutdriver.—**Hunter Tools**, 9674 Telstar Ave., El Monte, CA 91731.

CIRCLE 91 ON FREE INFORMATION CARD

MICROWAVE LEAKAGE MONITOR, model 245M is an easy-to-use, hand-held, portable instrument designed for the consumer, industrial engineer, or service technician who wishes



to check for microwave oven leakage. The self-contained instrument operates without batteries or any external power and is designed to check for 2,450-MHz microwave leakage in the home, industry or commercial establishment. The meter reads from zero to ten milliwatts per square centimeter. The model 245M is a direct-reading instrument mounted in an impact-resistant case. It is approximately 2 inches wide by 4 inches high by 1 inch deep. \$49.95.—**UCE, Inc.**, 20 North Main, Norwalk, CT 06854.

CIRCLE 92 ON FREE INFORMATION CARD

KRIKET AUTO SPEAKER, Series 6000, model KK-6069, is an acoustically designed 6 x 9 inch convertible (surface or flush) mount external speaker. It handles up to 30 watts RMS and has 8 ohms impedance. Extended frequency response of 35 Hz to 20,000 Hz is provided through a dual-cone design, while superior sound dispersion is assured by exclusive air suspended front-load speaker mounting technique. The new stereo speaker, made of impact-resistant Dylark in black Duralex, mounts on the rear deck, dashboard or any surface selected, or it snugs under the deck, with or without grille exposure. The unit comes complete with instructions and mounting hardware for either application and an 18 1/2-foot cable. Weighing 6 pounds, each speaker retails for about \$44.95.—

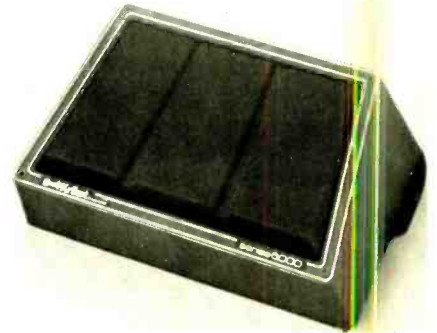

Acoustic Fiber Sound Systems, Inc., 7391 Knue Rd., Suite 116, Indianapolis, IN 46250

CIRCLE 93 ON FREE INFORMATION CARD

HIDE-IT TRUNK MOUNT. The model CETM-20 is a new quick-disconnect trunk mount for CB antennas which can be placed almost anywhere in the trunk of an automobile without the need to unscrew the antenna from the mount. It

Get More from Your Car with a Mark 10 System.

The best-selling CDI system of its kind in the world—now at discount prices!

Would you like more power? Better mileage? And could you stand to eliminate 3 out of 4 of those expensive tune-ups? Well, that's what the MARK 10 capacitive discharge electronic ignition system is all about. Very simply, it boosts the spark to your engine—promoting better combustion, and minimizing combustion contaminants. Spark plug life is extended, all-weather starts are insured, and you can feel an increase in acceleration and overall engine performance—no matter what kind of car you drive. Learn more about a MARK 10 CDI system for your car (and take advantage of year-end discount prices), when you write today for a catalog and price list.

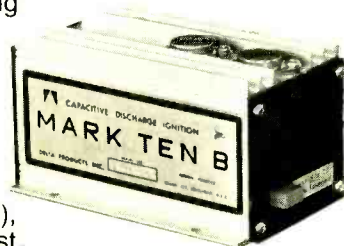

CIRCLE 69 ON FREE INFORMATION CARD

DELTA PRODUCTS, INC.
P.O. Box 1147, Dept. RE
Grand Junction, CO 81501
(303) 242-9000

I want to know more about Mark Ten CDI's. Send me complete no-nonsense information on how they can improve the performance of my car.

Name _____

Address _____

City _____ State _____ Zip _____

FEBRUARY 1977

EDI

ULTRASONIC TRANSDUCER

Transmits or receives 40K Hz ultrasonic waves. Used in building remote controls, for radios, TV's, appliances, remote switching, signaling and ultrasonic intrusion protecting devices and alarms.

M-1 **2.49**

DYNAMIC TRANSISTOR CHECKER

Tests transistors in circuit or out of circuit. The Dynamic Transistor Checker lets you match transistors in working circuits to improve the operation. It will test Go and No Go at currents from 5ma to 50ma, and will show current gain, electrical open and short circuits. Tests low, medium and high power transistors both PNP and NPN types. Complete with transistor socket test clips and leads. Uses VM2 or C1 1/2 battery. Size of case: 6 1/4" x 3 1/4" x 2"

F-144 **9.99**

DC POWER SUPPLY

This DC power supply will deliver four ranges of DC voltages 4.5V, 6V, 9V and 12V. It will supply a fully filtered output of one of these voltages at 150 milliamperes capacity. Can be used for any DC power supply within the voltage range and capacity, such as: operating a small battery radio, operating a small calculator, or powering miscellaneous laboratory experiments. Uses standard 117V 60C AC power. Output binding posts accepts wire or banana plugs. With 4 1/2 Ft. cord and plug. Size of case: 5" x 2 5/8" x 1 5/8"

F-145 **5.99**

TRANSISTORIZED SIGNAL TRACER

EDI Special!!

This transistorized signal tracer can be used by technicians and service men to audibly trace signals of RF and IF and audio circuits from the antenna to the speaker stage by stage. An ideal tool for servicing audio equipment: amplifiers, tuners, receivers, luminaires, etc. Has 2" speaker and test leads. Uses N556 9V transistor battery. Size of case: 5" x 2 5/8" x 1 5/8" Leads and Instructions Included.

Was 17.88
F-171 **9.99**

ELECTRONIC DUAL TRACE OSCILLOSCOPE CONVERSION INSTRUMENT

Convert Your Old Oscilloscope To Dual Trace With Simpson Model 318-SR.

Now you don't have to trade in your old oscilloscope. You now can easily convert it to an up-to-date dual trace scope with the Simpson model 318-SR conversion instrument. For just a fraction of Simpson's original suggested selling price of \$189.95.

Specifications: Switching Rates Approximately 150-500 15000Hz

Signal Frequency Response $\pm 1db$ 0-100K Hz Maximum Signal

Output 25-Volt Peak to Peak Input Impedance 100K Ohm Maximum

Input At Max. Gain 5-Volt Peak to Peak Dimensions 11 1/2" H x 7 1/4" W x

7 1/2" D

LIMITED QUANTITY

F-486 EDI Value Price **29.99**

VOICE ACTIVATED SOLID STATE SWITCH

Locks on when activated and opens when circuit is momentarily disconnected. Features sensitivity adjustment.

S-45 **1.49** 3/4.00

PANASONIC MODEL 450C-II CD-4 SEMICONDUCTOR TYPE STEREO CARTRIDGE

Special Diamond Stylus Tip • Stylus Pressure Range 1.5 to 2.5 gr.

Special! **59.88** Value

CB-11 **19.99**

24-KEY DESK CALCULATOR KEYBOARD

High Torque Type • Available in

Local Build • Frame, Body, Keys, and 4 Side

Switches • 5/16" S x 3/11" D • 4.3" L

Height • 1 1/4" • 1/2" • 1/2" • 1/2"

Shipping at 1 lb.

1.99

3/5.50

SPERRY-RAND UNIVAC KEYPUNCH KEYBOARD ASSEMBLY

A fantastic assembly filled with quality component parts. The ideal training keyboard • a super bargain on a complete assembly. Size: 13" x 8 1/2" x 4 1/2" Shipping Wt. 10 Lbs.

N-45 **18.88**

PKG/10 1 1/2-VOLT HOBBY MOTORS

- High Torque Type, Small In Size
- Ideal For Hobbyists, Experiments, Etc.

X-11 **.99**

PRECISION 1-RPM TIMING MOTOR

- Timing Motor For Clocks, Displays, Etc.
- Shipping Wt. 1.0 LB.

G-400 **.39** 3/1.00

4-RANGE DIGITAL READOUT INTERVAL TIMER KIT

- 4 time functions: 1.99 Sec., 1.99 Sec., 1.99 Min., 1.99 Min. • 1/2" High Nixie Tube Readouts
- For darkroom use in both processing & enlarging processes
- As a timer for sport & contest events (stop switch)
- Provides timed 120V AC outlet and S.P. NO contact to trigger buzzer alarm or visual signals
- Full Wiring Instructions included - No Cabinet Or Case Available For Timer

100.00

VALUE • Accurate to 1/10 of 1%

• LED For Visual Timing

SPECIAL **19.99**

Send for free catalog - satisfaction guaranteed

Min. Order \$3.00 - Allow For Postage

Ill. Residents Add 5% Sales Tax

Prices good thru February 28, 1977 or while stocks last.

Notice: Some items may be of limited quantities and subject to prior sale.

ELECTRONIC DISTRIBUTORS, INC.

DEPT. RL 1-4900 ELSTON

CHICAGO, ILL. 60630

Tel: 312/283-4800

detaches quickly for storing and does not interfere with the tire, jack, luggage, etc. The *Hide-It* mount and antenna is easily attached into its secure operating position by an adjustable

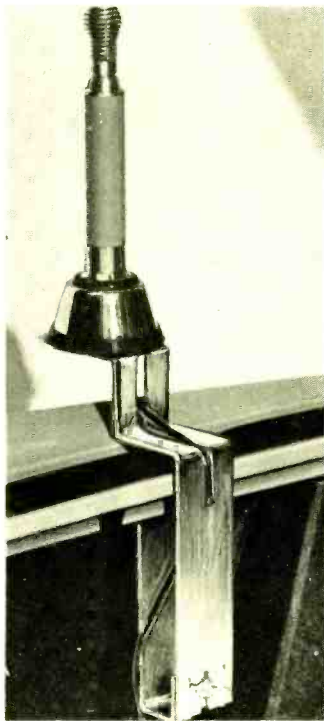

bracket which fits most cars and accepts most CB antennas. Chrome finished, the mount is complete with self-adhering rubber strip to protect the car's finish and secures the coaxial antenna cable in place, and is self-grounding. \$11.95 -RMS Electronics, Inc., 50 Antin Place, Bronx, NY 10462.

CIRCLE 94 ON FREE INFORMATION CARD

CB BASE-STATION ANTENNA, model 11-101, is a 27-MHz quarter-wave, beta-matched,

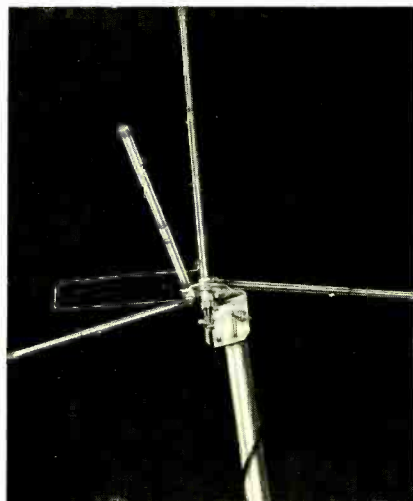

ground-plane design. It consists of three quarter-wave 108-inch radials to produce the elevated ground-plane, plus a vertical quarter-wave element for signal transmission and reception. All elements include static arrestors, built-in lightning protector and may be fastened to masts up to 1 5/8 inches in diameter. The antenna terminates with a 50-ohm impedance to a SO-239 connector that mates with a standard PL-259 plug.-Breaker Corporation, 1101 Great Southwest Parkway, Arlington, TX 76011.

CIRCLE 95 ON FREE INFORMATION CARD

STEREO CHORD EGG



THE ULTIMATE MEDITATION ENVIRONMENT MACHINE

The EGG plugs into any stereo amp to create soothing, flowing environmental sound textures - and through headphones it's incredible. The chords and notes EXIST in your mind, they pan and swell and phase their way through your psyche in unpredictable patterns never repeating.

The combination of LSI organ technology with synthesizer-type processing and digital randomizing/control elements make the EGG an altogether intriguing package from either technological or metaphysical viewpoints.

Kit includes: Circuit board, parts and step-by-step instructions.

CHORD EGG Kit \$24.95 postpaid

*Encephalo Gratification Generator

FREE CATALOG -
ELECTRONICS DEPT. 2-R
1020 W. WILSHIRE BLVD.
OKLAHOMA CITY, OK 73116

CIRCLE 11 ON FREE INFORMATION CARD

NEW! D.V.M. KIT



KIT FEATURES BASIC 2 RANGE D.V.M. ACCURATE TO 1%. CIRCUITS FOR ADDITIONAL VOLTAGE RANGES, OHMS, D.C. CURRENT, AND A.C. VOLTS CAN BE ADDED. PARTS MOUNT ON EDGE CARD CONNECTOR P.C. BOARD. DISPLAY BOARD HAS EASY TO READ 1/8" LED'S AND CAN BE REMOTE MOUNTED.

KIT CONTAINS • 2 P.C. Boards • Signal Converter • Digital Processor • Op. Amp • Inverter • 3-Drivers • 4-LED Displays •

Basic D.V.M. Kit \$39.90
(POWER SUPPLY NOT INCLUDED)

Send Check Or Money Order. Add \$1 for Postage and Handling in U.S. N.J. Residents Add 5% Tax.

J. B. Electronics Inc.
Box 321
Short Hills, N.J. 07078

CIRCLE 66 ON FREE INFORMATION CARD

ULTRA-MINIATURE AM RADIO, stock No. 1976 is a tiny $1\frac{1}{16} \times 1\frac{1}{16} \times \frac{11}{16}$ inches and weighs $1\frac{3}{4}$ ounce. Earphone listening only, the radio can be carried easily in your pocket; will



operate for approximately 100 hours on two hearing-aid batteries (included). Priced at \$14.95.—**Edmund Scientific Co.**, 380 Edscorp Bldg., Barrington, NJ 08007

CIRCLE 96 ON FREE INFORMATION CARD

MOBILE SCANNING RECEIVER, Globe 9700 accommodates 16 standard crystals, providing eight low-band or eight high-band channels, or



any combination of the two. A convenient band selection switch allows instant and safe band

switching while the scanner is in operation. Operates from either AC/DC supply and comes complete with AC/DC power cords, Mounting bracket, antenna and hardware, less crystals—**Globe Electronics**, Div. of Hydrometals, Inc., 400 S. Wyman, Rockford, IL 61101

CIRCLE 108 ON FREE INFORMATION CARD

FOLD-DOWN CB ANTENNA. A line of full-sized, 40-channel coil-loaded whip antennas that can be conveniently flipped down and hidden in the automobile trunk when not in use. Both, base-loaded and center-loaded models are available. Chrome-plated bracket serves as a self-ground-

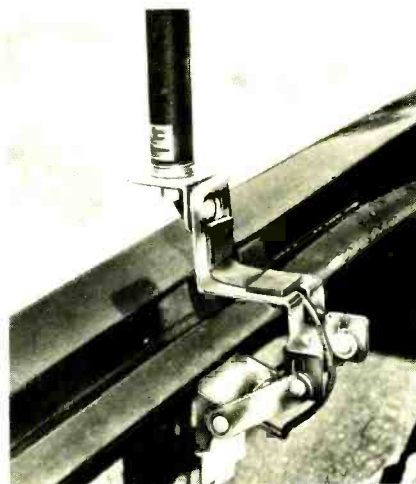

ing base. It is designed to fit most domestic and foreign cars and can be purchased separately for use with an existing antenna—**Channel Master**, Div. of Avnet, Inc., Ellenville, NY 12428

CIRCLE 109 ON FREE INFORMATION CARD



**endeco
soldering &
desoldering
equipment**

SOLDERING IRONS



Pencil style. Safety light. Two heats — 20w and 40w. 6 tips. Unbreakable handle. 2 and 3 wire neoprene cords.

DESOLDERING IRONS



Pencil style. Safety light. Some operate at 40w, some at 20w. 8 tip sizes. 2 and 3 wire neoprene cords.

SOLDERING & DESOLDERING BITS

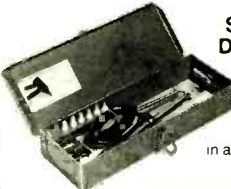

Everything needed to solder or desolder or both. All in a handy lifetime metal box with hasp.

See your distributor or write...

Enterprise Development Corp.
5127 E. 65th St. • Indianapolis, IN 46220
PHONE (317) 251 1231

CIRCLE 38 ON FREE INFORMATION CARD

Performance where it counts

for CB...
and beyond

These two new wattmeters from VIZ not only let you take advantage of the current CB boom, but also provide exceptional testing capabilities for ham, fm, vhf... even uhf.

Dummy-load rf wattmeter

- Broadband (1.9 MHz to 512 MHz)
- Easy to operate and read
- VSWR less than 1.15 at 500 MHz

Thru-line rf wattmeter

- Frequency range 20 MHz to 230 MHz
- Power range 100W or 20W (reflected power 20W or 5W)
- VSWR less than 1.15

See them at your VIZ distributor

VIZ Test Instruments Group
of VIZ Mfg. Co.

335 E. Price St.
Phila. PA. 19144

© VIZ
6710

Formerly
Instruments

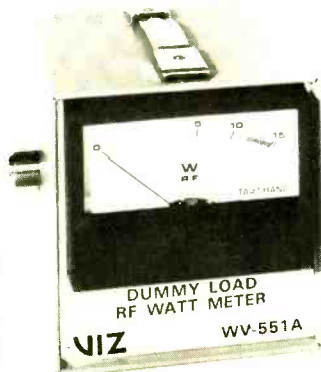

Model WV-551A
\$60.00



Model WV-552A
\$150.00

CIRCLE 53 ON FREE INFORMATION CARD

Test Equip. Special Discount Prices



- RCA 110 FLYBACK TRANS. For Bk. & Wht. sets 18KV 3 95
- 110- TV DEFLECTION YOKE for all types TV 4 95
- "COMBINATION SPECIAL" RCA 110- FLYBACK & YOKE 6 95
- 90- COLOR YOKE for rect. 19 to 25" CRT's 7 95
- 70- COLOR YOKE for round color CRT's 5 95
- UHF TUNERS Transistor type used in all TV sets 2 95
- GE UHF TUNERS Transistor Type Model 85A1 3 95
- ADMIRAL TUNER Model 94C393-1 (Series) 7 95
- ADMIRAL TUNER Model T94C411-3 (Transistor) 7 95
- GE TV TUNER Model = EP86X11 (Series) 7 95
- PHILCO UHF/VHF TUNER Transistor type 9 95
- ZENITH TUNER Model 175-1164 or 175-1151 9 95
- BLUE LATERAL MAGNET ASSY Repl. for most TV 1 79
- COLOR DELAY LINE used in most TV 1 69
- ZENITH SILICON STICK RECTIFIER Part # 103-215 5 95
- ZENITH TRIPLER Part # 212-109- Same as ECG501 3 95
- 3-POLARIZED CHEATER CORDS Grey 1 00
- COLOR POWER TRANSFORMER RCA Part # 20R150 7 95
- 2-COLORBURST CRYSTALS (3570-148KV) 1 89
- 3-COLOR TV RECTIFIER 600KV 1 95
- 6-TV ALIGNMENT KIT most popular type 2 79
- 4-TV ALIGNMENT KIT useful asst. 1 00
- 5-DUAL DIODE most popular type (Common or Series) 2 50
- VU "T" PANEL METER 0-20 db Scale 1 29
- CO-AX CABLE RG59U (Bk.) (250'-\$10.00) 2 69
- HI VOLTAGE POWER TRANSISTOR Equip. to Rev. 707 2 29
- TRANSISTOR RADIO asst. types (good, bad, broken, asst.) 1 50
- TAPE RECORDERS asst. types (good, bad, broken, asst.) 4 00
- 100' GREY SPEAKER WIRE 2 00
- UNIVERSAL TV ANTENNA back of set type (5 section) 2 99
- 3-ZENITH VIDEO AMPLIFIER Part # 121-743 2 00
- WAHL CORDLESS SOLDER IRON (complete with charger) 17 95
- 8" HEAVY DUTY 100Z. SPEAKER ceramic type 8 ohm 5 50
- 6"x5" HEAVY DUTY 100Z SPEAKER Cer. Type 8 Ohm 5 50
- STEREO HEADPHONES HI FI Quality with plug 5 95
- TACHOMETER 2 1/4" SQUARE PANEL METER 1 VDC 0-6000 RPM 2 00
- CASSETTE TYPE MIKE Universal Plug-200 Ohms 2 99
- 5 ZENIER DIODES 1N4751A-1 W-50 V 1 00
- 1-3" TWEETER closed back 1 59
- 2-HEP S0015 SILICON TRANSISTORS 1 00
- 1-HEP S5004 SILICON MPN TRANSISTOR 1 00
- 1-HEP S5011 OR HEP S5012 HV TRANSISTORS 1 00
- TRANSISTOR SPECIALS SK3006, SK3018, SK3020 1 ea. 1 00
- TRANSISTOR SPECIALS SK3022, SK3124 1 ea. 1 00
- TRANSISTOR SPECIALS SK3009, SK3024, SK3030 1 ea. 1 00
- GE IC3 OR IC4 INTERGRATED CIRCUIT 1 00
- 6-SILICON RECTIFIERS 1 Amp-1000 HV 1 00
- 7 TUBE AM FM STEREO AMPLIFIER CHASSIS complete with tubes as is 9 95
- DELUXE PILLOW SPEAKER with plug & volume control 2 49
- 2-12BH7 WESTINGHOUSE TUBES 1 00
- 8-MINI PILOT BULBS (6.3V-30Ma) or (6.3V-150Ma) 1 00
- 3"x5" SPEAKER TV replacement 1 39
- 1-ELECTROLYTIC COND. 300MFD-250V 1 00
- 3-ELECTROLYTIC COND. 100/80/20 Mfd-300V 2 00
- 3 PACK C-60 CASSETTE fine quality 1 50

Minimum Order \$5.00 Immediate Delivery

BROOKS RADIO & TV CORP.
529 Columbus Ave., New York, N.Y. 10024
TELEPHONE 212-874 5600

CIRCLE 31 ON FREE INFORMATION CARD

new lit

More information on new lit is available from the manufacturers of items identified by a Reader Service number. Use the Free Information Card following page 106.

CASSETTE TAPE AND HOW TO MAKE IT WORK FOR YOU, No. CB-1-176-25, is a 28-page booklet containing practical information on the selection and use of cassette recorders/players.

The booklet describes cassette tapes and explains in detail the steps to take before recording. Includes a section on the language of cassette tapes and converting engineering terms into plain English.—Send SASE to Audio Tape Division Fuji Photo Film U.S.A., Inc., Empire State Building, New York, NY 10001.

FLAT CABLE AND CONNECTOR CATALOG, No. FC-2, is a 20-page, 2-color catalog. The catalog covers a complete line of flat cable and connectors used for multiple termination in electronic circuits.

The catalog includes complete information on the company's 14- to 50-conductor flat cable. 14- and 16-pin DIP IC connectors, female socket connectors in 20- to 50-pin versions, straight and right-angle terminal headers to mate with the female socket connectors, PC board connectors and assembly tools consisting of a bench press, universal adapter and a low-cost hand tool for DIP connectors.

The new connectors are designed to permit the user to inspect the connections before covering and crimping. Connections can be checked for proper contact and conductors can be examined for proper alignment before final installation. Socket contacts have self-cleaning dual-cantilever construction for lower resistance connections. The connectors also have built-in strain relief so that cables will not pull apart. Assembly of the connectors can be made on a unique bench press with universal adapter that accepts all connectors without additional components or adjustments.

Features of the new Alpha flat-cable include compatibility, excellent tear-down characteristics and high resistance to damage due to repeated folding and bending. The cable is rated at 300 volts and is UL listed.—Alpha Wire Corp., 711 Lidgerwood Avenue, Elizabeth, NJ 07207.

CIRCLE 97 ON FREE INFORMATION CARD

CIRCUIT DESIGN AIDS, 26-page catalog contains electronic circuit design aids from sockets and breadboards to complete educational systems. Described are systems for teaching and experimenting with operational amplifiers, integrated-circuit logic and microprocessors. Complete specifications, technical data and prices are included.—E & L Instruments, Inc., 61 First Street, Derby, CT 06418.

CIRCLE 98 ON FREE INFORMATION CARD

TEST INSTRUMENTS, 40-page illustrated catalog includes oscilloscopes, analog and digital multimeters, frequency counters, signal generators, semiconductor and transistor testers and numerous other test instruments. The catalog lists the features and complete technical specifications for each instrument.—B&K Precision, Dynascan Corporation, 6460 W. Cortland, Chicago, IL 60635

CIRCLE 99 ON FREE INFORMATION CARD

FREE catalog
over 2000

unique tools, handy kits, precision instruments, technical supplies.

Over 24 years of service to the world's finest craftsmen and technicians.

A carefully selected and tested assortment of unique, hard-to-find tools, clever gadgets, precision instruments, bargain kits. One-stop shopping for the technician, craftsman, hobbyist, lab specialist, production supervisor. Many tools and measuring instruments available nowhere else. One of the most unusual and complete tool catalogs anywhere. Get your copy of the NC FLASHER today.

National Camera
2000 West Union Ave., Dept. GBA
Englewood, Colorado 80110
(303) 789-1893

CIRCLE 15 ON FREE INFORMATION CARD

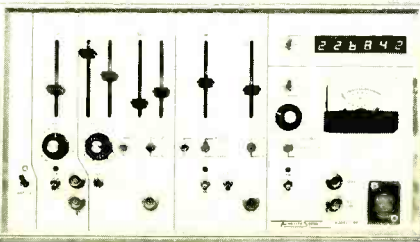

MODEL 100A AUDIO RESPONSE PLOTTING SYSTEM and general purpose sweep/tone burst/pulse generator consists of two sine /square/triangle function generators, pulse generator, frequency counter and peak amplitude measurement sections. It is primarily intended to generate a frequency response plot on an X - Y recorder or scope.

Time base generator offers symmetrical or independent control of the positive and negative sides of the ramp providing a duty cycle of .7% to 99.3%. Frequency range is .0035Hz to 100kHz. Amplitude is 15Vpp into 500 Ω with ±5VDC offset. The time base output drives the X axis of an X - Y recorder. Manual mode provided for setup.

Audio sweep generator provides manual frequency adjustment or log/linear sweep of 20Hz to 20kHz. Blanking mode produces zero reference line on X - Y recorder or tone burst. Amplitude is 15 Vpp into 500 Ω or 10 Vpp into 8 Ω.

Pulse generator frequency range is .0035Hz to 525kHz. Pulse width is adjusted independent of frequency from 4 seconds to 40 nanoseconds. Outputs are complimentary TTL.

Peak amplitude measurement section measures internal or external signals from mike to power amp level. Amplitude output drives Y axis of X - Y recorder.

Frequency counter is 6 digit, line triggered, and reads either internal or external. Sensitivity is 50 mv peak at 20kHz.

Dimensions: 8 x 14 x 3. Shipping Weight 9 lbs. S550, stock to 30 days. Warranty: 1 year.

FIDELITY SOUND
1894 Cornercenter W. #105
San Bernardino, CA 92408
(714) 889-7623

CIRCLE 10 ON FREE INFORMATION CARD

next month

MARCH 1977

Hi-Fi Issue

Loaded with special articles on the latest developments in high fidelity sound reproduction.

■ Q-Biphonic.

A new way to reproduce recorded sound. Delivers the effects of binaural listening without the headphones. You'll want to know how the system works. It's a 4-channel system.

■ Industry Innovations.

Report from Tokyo and New York. Infrared link to headphones. Three new biphonic and binaural systems are highlighted. And more.

■ Audio Rectification.

How to eliminate unwanted RF signals picked up by your hi-fi system.

■ Two More Lab Tested Reports.

Nakamichi 610 preamp and Garrard GT-55 turntable.

PLUS

Phase-Lock-Loop For CB

Action Football

Another IC Data Sheet

Service Clinic

Analog Multimeters

FCC LICENSE STUDY GUIDE

If you have experience or training in electronics, but need specific help in preparing for FCC license exams, perhaps you need *Grantham's FCC License Study Guide* — not a Q&A book, not a correspondence course, but simply an authoritative, down-to-earth presentation of what you should know to pass your FCC exams for 3rd, 2nd, and 1st class radiotelephone licenses. Included are four information sections, and 1465 FCC-type multiple-choice questions with more than 65,000 words "explaining" the correct answers. The book is 7 x 10 1/2, with 377 pages. Self-study presentation. Now, only \$10.70 *postpaid*. Order from:

GSE Publishing Company
2000 Stoner Ave., Los Angeles, CA 90025

GRANTHAM OFFERS YOU College-Level Training

and a college degree.

Electronic circuit design, engineering analysis (including math through calculus), classical and solid-state physics, computer science, etc., etc., are all part of the Grantham home-study electronics degree program.

PUT PROFESSIONAL RECOGNITION IN YOUR CAREER.

By adding college-level home training and a college degree to your experience, you can *move up* to greater opportunities in electronics.

Grantham offers the A.S.E.T. degree by correspondence. After earning this degree, you may continue with additional correspondence plus a 3-day residential seminar and certain transfer credits, to earn the B.S.E.E. degree. Our *free* bulletin gives complete details of the program itself, the degrees awarded, the requirements for each degree, and how to enroll. Write, or phone (no collect calls please), for our free BULLETIN R-77.

GRANTHAM SCHOOL OF ENGINEERING

2000 Stoner Ave., Los Angeles CA 90025

● Telephone (213) 477-1901 ●

Worldwide Career Training thru Home Study

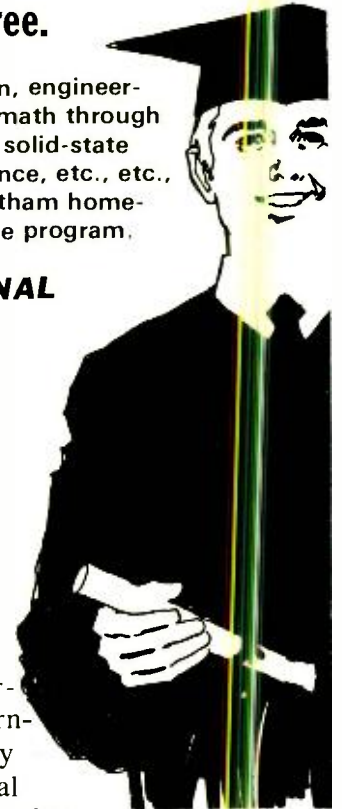

If you want a microcomputer with all of these standard features...

- 8080 MPU (The one with growing software support)
- 1024 Byte ROM (With maximum capacity of 4K Bytes)
- 1024 Byte RAM (With maximum capacity of 2K Bytes)
- TTY Serial I/O
- EIA Serial I/O
- 3 parallel I/O's
- ASCII/Baudot terminal compatibility with TTY machines or video units
- Monitor having load, dump, display, insert and go functions

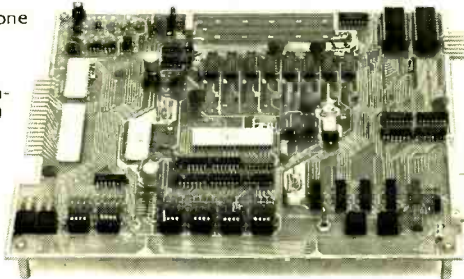

- Complete with card connectors
- Comprehensive User's Manual, plus Intel 8080 User's Manual
- Completely factory assembled and tested—not a kit
- Optional accessories: Keyboard/video display, audio cassette, modem interface, power supply, ROM programmer and attractive cabinetry... plus more options to follow. **The HAL MCEM-8080. \$375**

...then let us send you our card.

HAL Communications Corp. has been a leader in digital communications for over half a decade. The MCEM-8080 microcomputer shows just how far this leadership has taken us... and how far it can take you in your applications. That's why we'd like to send you our card—one PC board that we feel is the best-valued, most complete

microcomputer you can buy. For details on the MCEM-8080, write today. We'll also include comprehensive information on the HAL DS-3000 KSR microprocessor-based terminal, the terminal that gives you multi-code compatibility, flexibility for future changes, editing, and a convenient, large video display format.



HAL Communications Corp.
Box 365, 807 E. Green Street, Urbana, Illinois 61801
Telephone (217) 367-7373

CIRCLE 6 ON FREE INFORMATION CARD

Circuits happen Faster and Easier with Super-Strip.™

As little as
\$17

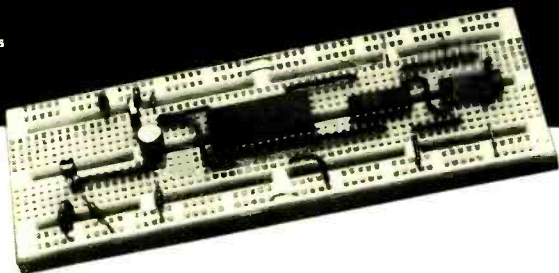

Now, whenever you'd like to give a circuit a try, you can build it up nearly as fast as you can dream it up with Super-Strips™, the faster, easier and less expensive solderless breadboards from A P Products. When you build your circuit on a Super-Strip, everything stays as good as new. Once you're through, you can use everything again and again. Instantly. Put a Super-Strip to work for you. Eight distribution lines handle signal and power, and 128 five-tie-point terminals can handle 9 ICs and then some. It's a whole lot easier than printing a circuit and a whole lot handier than haywire.

Part Number	Model Number	Terminal Type	Price Each
923252	SS-2	nickel-silver	\$17.00
923748	SS-1	gold-plated	\$18.90

Order from your A P distributor today.

Our distributor list is growing daily. For the name of the distributor nearest you call Toll-Free 800-321-9668.



Send for our complete A P catalog, The Faster and Easier Book.

A P PRODUCTS INCORPORATED
Box 110-R Painesville, OH 44077 (216) 354-2101 TWX: 810-425-2250

CIRCLE 9 ON FREE INFORMATION CARD

State SOLID

Featuring a new integrated that simplifies sonar and anti-collision radar.

KARL SAVON
 SEMICONDUCTOR EDITOR

SONAR AND SODAR TECHNIQUES ARE THE BASIS of a variety of fish finder, burglar alarm, and collision avoidance products. A new integrated circuit from National Semiconductor reduces the active circuitry for this useful class of equipment to little more than the single chip and an ultrasonic transducer. The medium-sized 80 × 93-mil chip contains a complete transmitter-receiver.

Choice of two frequencies adapts the equipment to both water-confined Sonar (Sound Navigation and Ranging) and air-operative Sodar (Sound Detection and Ranging) systems.

Figure 1 is the functional schematic of National's LM1812 ultrasonic transceiver. The single transducer is time-shared by the receiver and transmitter circuits. One-millisecond transmit intervals are interleaved with longer, range-dependent intervals to listen for the reflected echo.

Modulation input pulses at pin 8 proportion the two time periods. Some applications generate the modulation pulse with a permanent magnet attached to an electromechanical display that excites an inductive pickup. Under the control of the pin-8 pulse, Q6 is turned on, enabling the gated oscillator tuned by the L1-C3 tank. The tank is used by both transmitter and receiver, ensuring that they are always at identical frequencies.

The transmitter

Multi-collector transistor Q7 couples the oscillator signal to the 1-μs one-shot. Having been enabled by the modulating pulse on pin 8, the monostable produces a pulse train of 1-μs positive-going pulses with a total 5-μs cycle time defined by the reciprocal of the 200-kHz oscillator frequency. Incidentally, 200 kHz is the water sonar application frequency. Because of the attenuation of the higher frequencies in air, a lower 40-kHz rate is used in sodar.

The 20 percent duty-cycle monostable output feeds the three-transistor transmitter output stage. One-ampere transmitter current pulses multiplied by the 12-volt supply is 12 watts of peak power, yet no special heat-sinking is needed. The power is dealt with by switching the output transistors on fully during the shorter 1-μs positive pulse.

Transistor Q14 is a buffer amplifier that turns on during the 1-μs period. When it is conducting, its collector is pulled low and an inverted modulation pulse appears at pin 7. Transistors Q15 and Q16 are a high-current-

of STATE

circuit from National Semiconductor
sodar circuitry. Useful as depth-finder
Also included is RCA microprocessor

gain Darlington output stage. The output voltage on pin 6 is limited to the base-emitter voltage drop of Q16 because as Q15 becomes saturated, the base and collector of Q16 are effectively tied together and Q16 looks like a diode. The base voltage of Q16 is the output voltage on pin 6.

With the output transistors off, no power is dissipated simply because there is no current. Switched on, the power dissipation of the output device is limited to the saturation V_{be} output times the output current. Averaging further limits the power dissipation to $1/5$ the peak power since the stage is only active for that portion of the total duty-cycle.

Technically, the output operation falls into the Class-C category since the stage conducts for less than half a cycle. The square-wave output is filtered by the low-Q tuned transformer network. Tuned to resonate with the combined cable and transducer capacitance, the transformer coupling tolerates field transducer replacements without retuning.

In some applications such as hydro-acoustic communication systems, either AM,

FM, or pulse modulation can be used at reduced power levels.

The ultrasonic receiver

When the input swings negative, capacitor C1 charges more positive at the base of Q1 due to the conduction of D1. Positive input signals then drive Q1 into conduction. Q2 is an emitter-follower that buffers the high-gain first RF stage from the gain control pot. The pot slider is coupled to the second RF stage that is biased by the same diode-capacitor method. Switching off the cascode transistor Q4 disables the second RF stage during the transmit mode.

During the longer receive periods, the base of Q4 is biased at two V_{be} 's above ground by D3 and D4 fed from a current source. The second stage of the receiver is disabled by duty-cycle control transistor Q5 to Q6. Turning on Q5 grounds the base of Q4 directly. When Q6 goes on, the subtractive effect of D5 and D6 also grounds Q4, shutting down the receiver.

L1-C3 acts as a selective filter tuned to

either 200 or 40 kHz in the receive portion of the sequence. Transistor Q7 senses the received signal to pulse-train detector Q8. Its purpose is to discriminate against noise. Two or three missing pulses allows C5 to charge sufficiently to dump the charge from integration capacitor C4. Noise reject pot R2 and series resistor R1 in combination with C4 provide an adjustable noise-threshold. After a number of cycles have been received, indicating a valid return echo, display driver Q10 turns on, which in turn drives display transistors Q11, Q12, and Q13. Like the transmitter stage, it can deliver ten watts of peak display drive.

The diagram shows an LED display although neon, digital, and CRT readouts can also be used. Neon displays common in depth measuring and fish finding equipment use a voltage step-up transformer. Various methods of chip protection are possible to prevent excessive current buildup in the transformer primary. Returning the transformer winding to an RC filter gives the peak power delivery of the capacitor and the long-

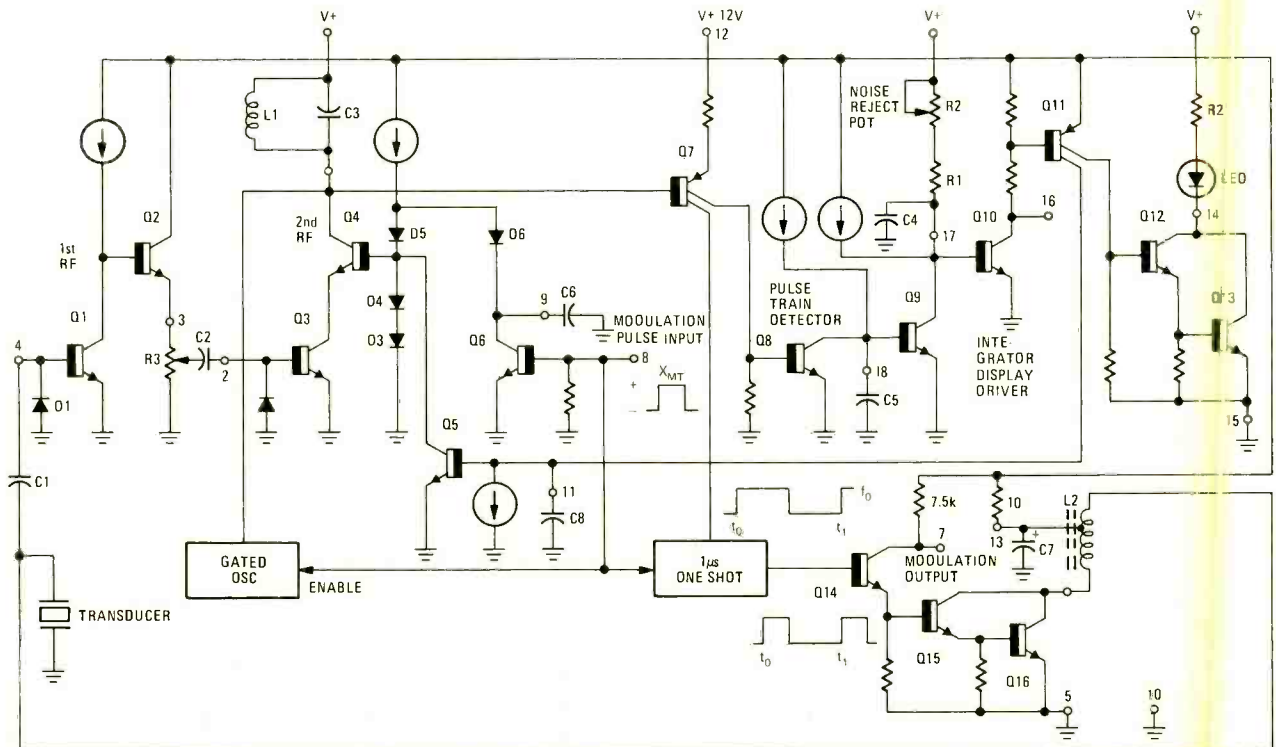

FIG. 1—NATIONAL SEMICONDUCTOR LM1812 ULTRASONIC TRANSCIEVER.



**save on gas!
save on tune-ups!
save on maintenance!**

Electronic ignition is "IN"! So says Detroit.

Update your car with either a TIGER CD or a TIGER I breakerless system.

Enjoy the benefits of better gas mileage, quicker starting, elimination of tune-ups, 50,000 miles on points and plugs, and reduced maintenance expenses.

TIGER MAX CD	\$69.95
TIGER 500 CD	59.95
TIGER SST CD	42.95
SIMPLIKIT CD	31.95
TIGER I	45.95

Postpaid U.S.A. only.

Tri-Star Corporation

Dept. WW, P.O. Box 1727
Grand Junction, Colorado 81501

CIRCLE 12 ON FREE INFORMATION CARD

term current limiting of the series resistor. The average output power is thus controlled, but high peak power surges are permitted.

The LM1812 is packaged in an 18-pin DIP and sells for \$12 in lots of 100. For additional information, contact National Semiconductor Corporation, 2900 Semiconductor Drive, Santa Clara, CA 95051.

CDP1802 microprocessor

Microprocessors are available in different technologies—PMOS, NMOS, bipolar, and CMOS. CMOS has the distinct advantages of low power dissipation and wide-temperature operation. RCA's 1801 microprocessor was a two-unit deal that was relatively slow and expensive. Started out at \$200, the price of the pair dropped into the still unattractive \$50 range.

But they haven't been sleeping! Just announced is a single-package CDP1802 COSMAC microprocessor that is a dramatic improvement over the earlier version. New instruction repertoire has been added, cost is competitive, down to under \$30 levels, and the execution speed of single-cycle instructions is down to 2.5 microseconds. Standard aluminum gate construction has been supplanted with a self-aligned silicon-gate process that cuts down chip area and increases yield.

RCA's new 230 × 180-mil μP retains the unique architecture of the older 1801 design. Programs written for the earlier circuit will run without change on the new one. It is built with a new C²L closed-COS/MOS logic. Source connections are common and separate contacts are not needed. Guardbands to

prevent parasitic action are not needed, yet the CDP1802D can operate at full supply range of 3–12 volts.

The CDP1802 block diagram in Fig. 2 shows an 8-bit address bus MA0 through MA7. The bus is time-multiplexed to 16 bits. Storing the first 8 bits in an external latch gives 65K of memory addressing capability.

Sixteen general-purpose registers distinguish the RCA approach from contemporary processors. Each register is 16 bits long, which adds up to 32 8-bit bytes or a total of 256 read-write scratchpad bits. By loading these registers with frequently used addresses and data, efficient programming code can be written. Single-byte instructions replace multiple-byte main memory addressing operations in other schemes.

Any register can be designated as the program counter or data pointer. One of three 4-bit registers selects the particular one of the 2⁴ scratchpad registers.

Many of the memory and register instructions include a 4-bit operand that is stored in the N register. The most significant 4 bits of the instruction is the operation code and is stored in the 4 bit I register. For example, the instruction format IN is an increment register operation. To increment register 5 by one, the instructions would be 15 in hex or 00010101 in binary. Binary number 0001 would be stored in the I register and 0101 in the N register. The control logic decodes the opcode and sends out signals to direct the N register to select register 5 in the array. The control logic then causes the addressed register to be incremented by one by the incr/decr block in Fig. 2.

Accuracy like a VTVM... Convenience like a VOM...

NEW BATTERY-OPERATED FET
SOLID-STATE VOLT-OHMMETER #116

Easy-to-build KIT

\$39.48 =116K

Factory-Wired & Tested

\$52.95 =116W

Now you can get all the benefits of a VTVM (laboratory accuracy, stability and wide range) but with its drawbacks gone: no plugging into an AC outlet, no waiting for warm-up, no bulkiness. New Field Effect Transistor (FET) design makes possible low loading, instant-on battery-operation and small size. Excellent for both bench and field work.

Compare these valuable features:

- High impedance low loading: 11 megohms input on DC, 1 megohm on AC
- 500-times more sensitive than a standard 20,000 ohms-per-volt VOM
- Wide-range versatility: 4 P-P AC voltage ranges: 0-3, 3, 33, 330, 1200V; 4 RMS AC voltage ranges: 0-1, 2, 12, 120, 1200V; 4 DC voltage ranges: 0-1, 2, 12, 120, 1200V; 4 Resistance ranges: 0-1K, 0-100K, 0-10 meg., 0-1000 meg.; 4DB ranges. -24 to +56DB.

Sensitive easy-to-read 4 1/2" 200 micro-amp meter. Zero center position available. Comprises FET transistor, 4 silicon transistors, 2 diodes. Meter and transistors protected against burnout. Etched panel for durability. High-impact bakelite case with handle useable as instrument stand. Kit has simplified step-by-step assembly instructions. Both kit and factory-wired versions shipped complete with batteries and test leads. 5 1/4"H x 6 3/4"W x 2 7/8"D. 3 lbs.

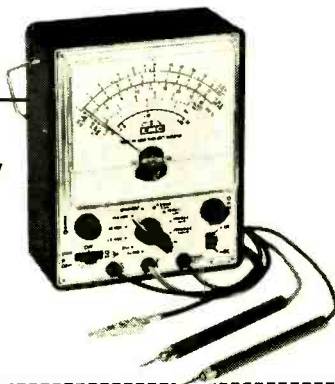

Send FREE catalog of complete EMC line and name of nearest distributor. RE-02

Name _____
Address _____
City _____
State _____ Zip _____

EMC

ELECTRONIC MEASUREMENTS CORP.
625 Broadway, New York, N.Y. 10012

FOR HOME AND INDUSTRY

WORLD'S MOST PRACTICAL SOLDER HANDLING TOOLS

**SOLDERING +
DESOLDERING +
RESOLDERING =**

SOLDER Ability ELEMENTARY TO ELITE

SEE THEM ALL!
AT

nepcon 77 west

contact your local DISTRIBUTOR inquiries invited

BOOTH 3033

MOST PRODUCTS COVERED BY U.S. AND FOREIGN PATENTS AND PENDING APPLICATIONS

EDSYN 144 PAGE TRAINING MANUAL
NEW! OVER 1000 ILLUSTRATIONS

1558 ARMINIA ST., VAN NUYS, CALIF. 91406
24 HR. PHONES Local (213) 989-2324 L.A. (213) 873-5115
CABLE: EDSYNEX VAN TELEX 65-1489

FANOVISION

CIRCLE 23 ON FREE INFORMATION CARD

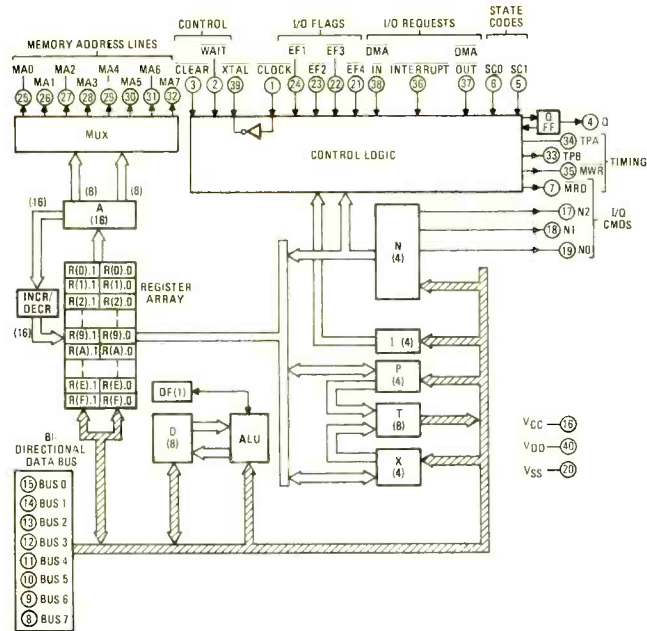
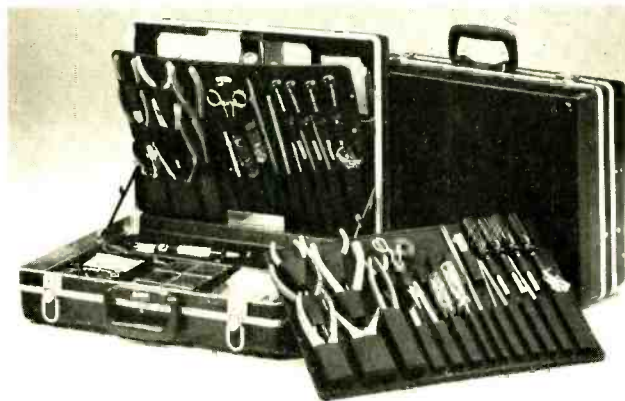

FIG. 2—BLOCK DIAGRAM OF THE RCA CDP1802.

In instructions where register addressing is not used, all 8 bits are interpreted by the control logic and none of the scratchpad registers are selected.

The 4-bit P register decides which of the 16 is to be used as the program counter. The program counter holds the address of the program stored in memory and is incremented sequentially to fetch successive program steps.

(Turn Page)



A Platt tool case won't fall apart at the seams because there are no seams.

Unlike other tool cases, the pockets on a Platt Pallet are molded without any seams, stitches or rivets to form a one-piece unit. It's practically indestructible.

The case itself has that same rugged construction. It comes in either tough, lightweight ABS Thermoplastic, rich looking expanded vinyl or a combination of both.

Platt also has rugged hardware. Like an aluminum rim for extra strength. Steel core handles. And tough brass locks.

Inside there are compartments for larger tools, parts boxes and testing equipment. And multiple lid pockets for paper and order books.

Besides having a tough case Platt has a tough 5-year guarantee on both the case and pallet.

platt

* Pat. No. 3,880,285 Cases for business and industry.

2301 S. Prairie Ave., Chicago, Ill. 60616 (312) 225-6670

CIRCLE 77 ON FREE INFORMATION CARD

the shocking truth



The world of electronics is becoming both larger and smaller. As its essential hardware is rapidly decreasing in size, the demand for competent technicians is rapidly increasing, especially in communications and marine technology.

The Jensen Beach Campus of Florida Institute of Technology offers an Associate of Science degree in Electronic Technology concentrating on the specialized skills needed in modern marine and communications applications. Students in this program receive broad academic training in electronics as well as diverse practical experience qualifying them for various career opportunities in industry.

To learn more about F.I.T.'s Associate of Science degree in Electronic Technology, return the coupon below today.

Florida Institute of Technology
720 S. Indian River Drive
Jensen Beach, Florida 33457

Name _____
Address _____
City _____ State _____
Zip _____ Phone _____
Age _____ Veteran Area Code _____

RERP 2/77

CIRCLE 3 ON FREE INFORMATION CARD

Money Generator

PAT. PEND.

\$299.95

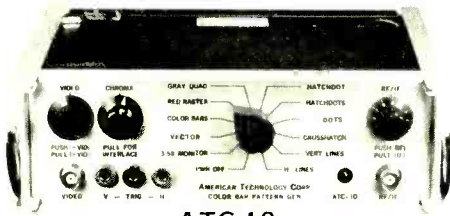

ATC-10 GENERAL TELEVISION SERVICER

- Extra wide range RF/IF attenuator for testing receiver sensitivity.
- GRAY QUAD pattern for gray scale tracking checks/adjustments.
- COLOR BARS pattern with 6th bar marked to make your job easier.
- 3.58 MONITOR pattern for oscillator frequency checks with no need to short the AFPC test point.
- RED RASTER pattern for checking and adjusting purity at the flip of a switch.
- All dot patterns have fine pinpoint dots.
- High level, 75 ohm video output.
- 2 year factory warranty.
- 30 day money back guarantee.



American Technology Corporation

225 Main Street, Dept. ICC, Canon City, Colorado 81212

Credit card & COD phone orders accepted. Same day shipment. (303) 275-8991, ext. 3

Versatile

Carl Babeoke (Electronic Servicing) says, "If I could choose only one of the many kinds of dot or crosshatch patterns, I would want this one." Think how much easier the composite HATCHDOTS pattern below would make your job. It can also perform size, linearity, pincushion and centering checks. It's only one of several unique patterns produced by the ATC-10 that can save you time, trouble and most important - money. We'd love to show you how. Write us.

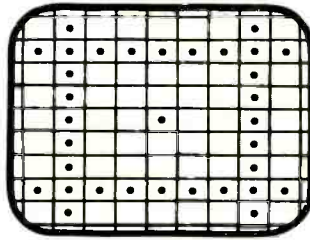

The 4-bit X register picks the register to be referenced by arithmetic and logic operations.

Interruptions in program executions by peripherals such as terminals and disk memories are standard computer procedures. The 8-bit T register is used to hold the X and P register contents and store them in a single memory-location. After servicing the interrupting device with a special program routine, the T register is used to reset X and P to their original values so the main program can continue from where it left off.

The 8-bit D register is the μ P accumulator. Data is transferred in either direction between the D and scratchpad registers. Since the general registers are twice the length of the D register, either the low or high byte can be loaded by separate instructions.

Data transferred to and from memory must pass through the accumulator and is handled by a series of eight memory reference instructions. The instructions use either the X or P registers as operands. These pointers will either stay fixed or will be automatically incremented by the choice of instruction.

Arithmetic and logic operations take place between memory and the D accumulator, governed by an extensive series of instructions. The 1802 has a number of new immediate instructions that are two bytes in length. These load constants or use them as other operands. Immediate means the constant is stored in the second byte of the instruction. This is very useful when setting up indexes or initial memory pointers, which can then be incremented or decremented by the program.

At the heart of many machine-language routines are the branch instructions, and a large assortment will save programming code. The 1802 selection includes two-byte short branches where the second byte is the address that replaces the low program counter byte. Jumps over a 2nd, 256 word total range on the same memory page use these instructions. New to the 1802 are long branches that are three-bytes and allow jumps to any location in memory. The high and low address bytes to be inserted into the program counter are in the second and third instruction words. Except for the unconditional branches, the decision to jump or not is based on the state of the D register, and the DF, Q, and EF flags. DF, the data flag, is a one-bit ALU carry flip-flop. Q is a program controlled flag, and EF1 through EF4 are a group of flags controlled by peripherals.

Short and long skip instructions are similar to the branches in that they are executed in response to the same flag conditions, but their action is limited to the skipping of either one or two steps in the program. They are single-byte instructions that are very efficient in terms of memory space.

The ten control instructions include the stack return and idle operations. The remaining group are the output instructions that route data from the registers pointed to by X to the output data bus or from the input data bus. During input-output operations, the 4-bit N register is set to a value between 1 and 7 and used to select the peripheral device.

The unit price of the 4-6-volt 5- μ s CDP1802D is \$29.50. The 3-12 volt full speed CDP1802CD is \$43.50. Information is available from RCA Solid State Division, Route 202, Somerville, NJ 08876. **R-E**

CIRCLE 47 ON FREE INFORMATION CARD



Now... PUSH-BUTTON REMOTE TV CONTROL

MODEL TRC-82

For ALL Channels
For ALL TV SETS!

- INSTANT PUSH-BUTTON CHANNEL SELECTION, UHF and VHF
- TURNS TV ON and OFF, FINE TUNES
- IMPROVES TV PICTURES—AMPLIFIES TV SIGNALS
- UL LISTED
- FCC CERTIFIED
- UNIVERSAL—WORKS WITH ANY TV
- SOLID-STATE VARACTOR TUNING

JERROLD ELECTRONICS
GENERAL INSTRUMENT CORPORATION
Horsham, Pa. 19044 • (215) 674-4800



CIRCLE 61 ON FREE INFORMATION CARD

FREE burglar — fire alarm catalog



mountain west
alarm supply co.

over 900
systems,
detectors,
controls,
sounders,
tools, locks,
supplies

TO PROTECT HOMES, BUSINESSES, INDUSTRY

Huge selection of hard-to-find security equipment from stock. 64 fact-filled pages loaded with 100's of highest quality professional alarm products, technical notes, diagrams.

ONE-STOP SUPERMARKET SELECTION INCLUDES:

ultrasonics, radar, infrared, undercarpet mats, magnetic contacts, smoke & heat detectors; Controls; Alarms; bells, sirens, phone dialers, lights, guard panels. Large selection of tools, relays, wire, holdup alarms, books. Fills need for industry, alarm cos., businesses, homes, institutions. Order your copy today. (Outside U.S., send \$1.00.)



mountain west alarm
4215 n. 16th st.
phoenix, az. 85016
(602) 263-8831

CIRCLE 8 ON FREE INFORMATION CARD

market center

CLASSIFIED COMMERCIAL RATE (for firms or individuals offering commercial products or services) \$1.40 per word (no charge for zip code) . . . minimum 15 words.

NONCOMMERCIAL RATE (for individuals who want to buy or sell personal items) 85¢ per word . . . no minimum

ONLY FIRST WORD AND NAME set in bold caps. Additional bold face (not available as all caps) at 10¢ per word. Payment must accompany all ads except those placed by accredited advertising agencies. 5% discount for 6 issues, 10% for 12 issues within one year, if paid in advance. All copy subject to publisher's approval. Advertisements using P.O. Box address will not be accepted until advertiser supplies publisher with permanent address and phone number. Copy to be in our hands on the 26th of the third month preceding the date of the issue (i.e. August issue closes May 26). When normal closing date falls on Saturday, Sunday or a holiday, issue closes on preceding working day.

EDUCATION & INSTRUCTION

TELEPHONE bugged? Don't be Watergated! Countermeasures brochure \$1.00. **NEGEYE LABORATORIES**, Box 547-RE, Pennsboro, WV 26415

ELECTRONICS DESIGN NEWSLETTER

Learn Design Techniques!

- ★ Logic Design Techniques
- ★ Digital & Linear Design Theory & Procedures
- ★ Construction Projects

Subscription \$6 Sample Copy \$1

VALLEY WEST Box 2119-L Sunnyvale, CA 94087

FREE educational electronics catalog Home study courses. Write to **EDUKITS WORKSHOP**, Dept. 288G, Hewlett, NY 11557

GRANTHAM's FCC License Study Guide—377 pages, 1465 questions with answers/discussions—covering third, second, first radiotelephone examinations. \$10.70 postpaid. **GSE PUBLICATIONS**, 2000 Stoner, Los Angeles, CA 90025

F.C.C. EXAM MANUAL

PASS FCC EXAMS! Memorize, study—Tests—Answers for FCC 1st and 2nd class Radio telephone licenses. Newly revised multiple choice questions and diagrams cover all areas tested in FCC exams, plus Self-Study Ability Test. \$9.95 postpaid. Money-back guarantee.

Tests—Answers for FCC First and Second Class Commercial License

COMMAND PRODUCTIONS P.O. BOX 26348 E
RADIO ENGINEERING DIV. SAN FRANCISCO, CAL. 94126

BUSINESS OPPORTUNITIES

BIG profit in Real Estate, learn from an expert how to successfully buy and sell residential and investment properties, plus **bonus** Real Estate definitions \$2.95. **LINPAUL ENTERPRISES**, Box 60, Dept. RE 277, West New York, NJ 07093

Independent News Company, Inc. is pleased to announce a Retail Display Plan available to all retailers interested in earning a display allowance on Radio-Electronics magazine and who purchase the magazines from suppliers other than Independent News Co., Inc., or the publisher.

To obtain details and a copy of the formal contract please write to **Director, Retail Sales Division, Independent News Co., Inc., 75 Rockefeller Plaza, New York, N.Y. 10019**. Under the display plan in consideration of your acceptance and fulfillment of the terms of formal contract to be sent to you upon your request you will receive a display allowance of 10% of the cover price per copy sold by you. This plan will become effective with all issues of Radio Electronics delivered to you subsequent to the date your written acceptance of the formal Independent News Co., Inc. Retail Agreement is received and accepted by our Company.

HIGHLY PROFITABLE ONE-MAN ELECTRONIC FACTORY

Investment unnecessary, knowledge not required, sales handled by professionals. Ideal home business. Write today for facts! Postcard will do. **Barta-BN, Box 248, Walnut Creek, CA 94597.**

CABLE FM station: Start your own. No investment, excellent income. Details free. **CAFM, Box 5516-FB, Walnut Creek, CA 94596**

YOUR HOBBY EXPENSES ARE TAX DEDUCTIBLE!

FOR FREE INFORMATION WRITE **FINANCIAL MANAGEMENT ASSOC., INC.** BOX 82129AD SAN DIEGO, CA 92138

WANTED

QUICK cash for electronic equipment, components, unused tubes. Send list now! **BARRY**, 512 Broadway, New York, NY 10012, 212 Walker 5-7000

PLANS & KITS

SAVE 50%. Build your own speaker systems. Write: **MCGEE RADIO ELECTRONICS**, 1901 McGee Street, Kansas City, MO 64108

TV JAMMER

Amaze your friends! Makes TV's go into distortion. Max. range 20'. IN EASY KIT FORM. **\$.265**

* SEND FOR FREE CATALOG *

PROS ELECTRONICS COMPANY
6827 Tobias Av. Van Nuys Ca. 91405

115 VAC STEREO TAPE DECK **24.95**

- SHIELDED PREAMP
- 115 VAC MOTOR
- READY TO GO
- WITH ALL CONUS
- SLIDES EASILY IN MODULAR CABINET

MOTOROLA

IT'S READY TO GO! Features: 115 VAC operation. An exceptional feature: 115 VAC motor, 10 "GLOW FREE" heavy duty wheel; built in power supply; built-in pre-amp, panel, black-and-silver-trimmed x 1 1/2 x 4 1/2 x 3/4" heavy duty plastic. Depth 8 3/4". Wt. 3 lbs. Cat. No. 2R3444

FAIRCHILD, NATIONAL VOLTAGE REGULATOR PANIC

YOUR CHOICE \$1

- TO-220 OR TO-3 CASES
- POSITIVE OR NEGATIVE
- 1-AMP RATING

3 for \$2.75

Cat. 2R3449 Positive Voltage** ** State voltage and one style when ordering.
Cat. 2R3450 Negative Voltage**

TOUCH TONE ENCODER KIT* 1888

REPEATER

1.25M, 2-meter and 6-meter amateur radio operators: if your rig is mobile, convert it easily to a mobile telephone station and contact your home, shop, school, factory TPE-100 touch tone encoder kit. Kit includes: Chomeric touch tone pad; Motorola MC1410 chip; trimpot, resistors, center, diagram, and G-10 pc board. Electrical specs: 12-16 volts, 5 mils (max), 100 volts PP output. * Less 1-MC crystal. Cat. No. 2R3385

Cat. No. Description Sale BUY 'EM
2R3149 Touch Tone Pad \$4.50 SEPARATELY
2R3382 MC1410 Chip 10.50
2R3383 P.C. Board 2.95

DIGITAL CLOCK MODULE \$14.95

WITH BUILT-IN "CHIP"

4-digit, 0.5" Digital Clock. LED, built-in red filter, with a MM5385 multi-function alarm chip, mounted on a 3 x 1 3/4 x 3/4" module. Has all necessary discrete components mounted on module by factory, to require only 6 function switches, brightness and voltage divider control, 12-16 volt filament transformer, AC line cord and case. Makes easy built-in alarm and line Alarm ON/OFF. Instruction and hookup diagrams. Slugg. wt. 7 ozs.

Cat. No. 2R3411

CITIZENS BAND POWER SUPPLY \$19.95

- 12 VDC @ 3 AMPS
- REGULATED, CONTINUOUS DUTY
- CONVERTS CB, HAM RIGS TO HOME

115V to 12VDC converter; built-in automatic RESET circuit breaker. Powerful 3 amps (8 amp peak) makes an ideal for SSB rigs, tool attractive styling. Like most modern design cabinet (5 x 4 1/2 x 2 3/4"). Big U.S. maker design. Built-in circuit breaker. Front panel has OFF-ON switch and LED light. For 115 VAC 60 cycle W. 5 lbs.

WIRED

Cat. No. 2R3452

Rotron Fans \$8.88

- 115 VDC
- Compact
- Lightweight
- Only 4 1/2" x 1 1/2" sq. x 1 1/2" deep!

Fans by Rotron. Used extensively for heat expt because of low-cost, dependable cooling, as well as flushing computers, power supplies, office equipment, light projectors, transmitters, receivers & more! Weighs only 1 lb. LOW NOISE. LEVEL Humidity & moisture resistant motor. REVERSIBLE AIR FLOW. Impeller protected. Suitable for -40° to +160° F. 115 VAC, 3200 rpm, 15 watts, 16 amps. Hi-impac. Flame retardant polycarbonate propellers in a reinforced phenolic control housing. Removed from new equipment. Money back guarantee. 1 1/2 lbs. 2R3108 "Mother" 3-blade

MICROPROCESSORS

- 8008 \$14.95
- 8080 \$24.95
- 2102-1 \$1.95
- 1702-A \$9.95
- MM5262 \$1.95
- 8 FOR \$11.95
- 3 FOR \$25.00
- 3 FOR \$3.00

Terms: Add postage. Rated: net 30
Phone: Wakefield, Mass. (617) 245-3829
Retail: 16-18 Del Carmine St., Wakefield, (Plus Postage)

POLY PAKS C.O.D.'S MAY BE PHONED

P.O. BOX 9422 LYNNFIELD, MASS. 01940

* Now — ... YOUR CAR WILL START

— even with a **LOW BATTERY!**
— even in **COLD WEATHER!**
— even in **DAMP WEATHER!**



... THANKS TO:

Coil Foil®

AUTOMATIC STARTING BOOSTER
... the Amazing New Invention!

* **GIVES YOU**
"Sure-Fire" **STARTS**
EVERY TIME...



If your Cold or Weak Battery can turn the Engine over just ONCE... COIL/FOIL will START your Car, even under the worst weather conditions, by Automatically providing a STRONG Spark from its OWN Power Source.

- **EASY-TO-INSTALL** (Only 4-Wires & 2-Bolts). Fits ALL Vehicles with Battery/Coil Systems.
- **COIL/FOIL Prolongs Car Battery Life...** and reduces wear and tear on Starter-Motor.



No one in your Family need ever be **STRANDED** with a Car that **WON'T START!** No more running the Car Battery "DEAD" trying to start the Car! COIL/FOIL uses its own Power (2-Dry Cell Batteries, not included) ONLY in Starting, and Batteries usually last a Year.

TESTED and APPROVED by Leading Automotive Magazines and Authorities!

Comes with... FACTORY WARRANTY.
Copy available on written request.
ADVANCED ELECTRONICS, N.V.,
1825 EYE St., N.W., Washington D.C. 20006

ORDER NOW! ... and never be caught with difficult Starting AGAIN! Install the COIL/FOIL and prove to yourself that it works or your money back.

SPECIAL
Introductory Offer
Only
\$19.95

ADVANCED ELECTRONICS, N.V.
P.O. Box 1579 — RA, 1, Washington, D.C. 20013

Please RUSH _____ COIL/FOIL Units to:

NAME _____

ADDRESS _____

CITY _____ STATE _____ ZIP _____

MAKE/YEAR of Vehicle _____

Add \$2 for Postage, Insurance & Handling. Canadian & Foreign Add \$3.

Enclosed: Check, M.O., in amount \$ _____

30-DAY "NO RISK" TRIAL... SATISFACTION GUARANTEED
or Return Unit in 30 days for Full Refund.

CIRCLE 71 ON FREE INFORMATION CARD

ADVERTISING INDEX

RADIO-ELECTRONICS does not assume any responsibility for errors that may appear in the index below.

Free Information Number Page

68	Acoustic Fiber Sound Systems	35
79	Allison Automotive	22
47	American Audioport	Cover III
9	American Technology	104
80	AP Products	100
31	B&K-Div. of Dynascan	38
	Brooks Radio & TV	98
	CIE-Cleveland Institute of Electronics	88-91
18	Cobra-Div. of Dynascan	Cover IV
67	Continental Specialties	13
	CREI-Div. of McGraw-Hill Continuing Education	70-73
84	Dana Labs	94
69	Delta Products	95
74	Digital Concepts	24
28	ECD	Cover II
2	EDI	96
20	Edmund Scientific	124
23	Edsyn	102
81	EICO	34
	E&I Instruments	85
	EMC-Electronic Measurement	102
34	Empire Scientific	86
38	Enterprise Development	97
10	Fidelity Sound	98
3	Florida Institute of Technology	103
1	GC Electronics	17
	GFN Communications	37
14	Grantham School of Electronics	99
	GTE Sylvania-Consumer Renewal	1
6	Hal Communications	100
100,102	Heath	18-21,26-27
58	Hickok Electrical Instruments	14
26	Indiana Home Study Institute	87
39	International Crystal	82
66	JB Electronics	96
60,61	Jerrold	33,104
78	Lectrotech	79
37	McGraw-Hill Books	5
22	MTI	84
8	Mountain West Alarm Supply	104
15	National Camera Supply	98
	National Radio Institute (NRI)-Div. of McGraw-Hill Continuing Education	8-11
	National Technical Schools	28-31
33	OK Machine & Tool	80,81
40	Optoelectronics	93
11	PAIA Electronics	96
77	Platt Luggage	103
56	PTS Electronics	84
	Radio Shack	23
	Rye Industries	94
35	Schober Organ	84
65	Sencore	36
76	Shakespeare	2
44	Shakespeare	2
54	Southwest Technical Products	83
17	TAB Books	16
29	Tektronix	25
72,73	Telematic-Div. of UXL	32,87
12	Tri-Star	102
49	Tuner Service	15
53	V.I.Z. Mfg.	97
27	Weller-Xcelite-Div. of Cooper Industries	7
	MARKET CENTER AD INDEX	
36	Active Electronics	121
71	Advanced Electronics	106

Free Information Number Page

	American Used Computer	120
	ATV Research	110
46	Babylon Electronics	116
	Karel Barta	105
	CFR Associates	110
	Command Productions	105
50	Delta Electronics	116
	Dextrox Organ Products	110
57	Digi-Key	113
	Fair Radio Sales	110
59	Fordham Radio Supply	112
16,45	Formula Electronics	111,116
	Financial Management Associates	105
30	Godbout Electronics	112
63	Hobby-tronix	122
	Information Unlimited	120
42	International Electronics	119
	Interfab	110
4,5	James	114,115
	Lab Science	110
	Lakeside Industries	110
51	Meshna	120
21	Mini Micro Mart	120
52	New-Tone	122
13	Nexus Trading	122
19	Olson Electronics	110
	P.P.G. Electronics	105
24,25	Poly Paks	105,123
41	Quest	118
75	Radio Hut	109
55	SD Sales	117
62	Solid State Sales	118
7	Surplus Center	118
	Trumbell	120
64	TV Tech Aids	112
70	Utrep Marketing	120
	Valley West	105
	Visulex	110

MOVING?

Don't miss a single copy of **Radio-Electronics**. Give us:

Six weeks' notice

Your old address and zip code

Your new address and zip code

ATTACH LABEL HERE

name (please print) _____

address _____

city state zip code _____

Mail to: **Radio-Electronics**
SUBSCRIPTION DEPT., P.O. BOX 2520,
BOULDER, COLO. 80302

Radio Hut

TERMS: Money Back Guarantee. No. COD's. Texas Residents add 5% Tax. Add 5% of order for postage and handling. Orders under \$10.00 add 75c. Foreign Orders: US Funds ONLY!

For your convenience, call your BankAmericard or Master Charge orders in our Continental United States. Call Toll Free. 1 - 800 - 527-2304. Texas Residents call Collect 1 - 214 - 271-8423.



P. O. Box 64783 Dallas, Texas 75206



VARIABLE POWER SUPPLY KIT

- Continuously variable from 3V to 20V
 - Excellent regulation up to 300 mill.
 - 3000 MFD of filtering
 - Fiberglass PC Board mounts all components
 - One hour assembly
 - Makes an excellent bench or lab power supply
 - Includes all components except meters
 - Yes, case is included
- ONLY \$9.95**

SOCKETS - Pulled from PC Boards

24 PIN Low Profile **6 for \$1.00**
 14 PIN Low Profile **8 for \$1.00**
 Solder Tail Limited Quantity

WATERGATE SPECIAL

Telephone relay automatically starts and stops tape recorder. No batteries required. Kit

complete with drilled PC Board. PARTS AND CASE - SATISFACTION GUARANTEED **ONLY \$10.95**

PLASMA Discharge Display

By National Electronics
 12 DIGIT DISPLAY .4" character
 Neon Orange in color
 Specs Included **Only \$.79**
 Money Back Guarantee

Complete Power Supply Kit for above, including P.C. Board XFMR, and Instructions. **Only \$3.25**
 Money Back Guarantee

VOLTAGE REGULATORS

LM340-6 LM340-15
 LM340-8 LM340-18
 LM340-12 LM340-24
 Your Choice - **Only \$.85 ea.**

TRANSISTORS

2N4400 6 / \$1.00
 2N5401 6 / \$1.00
 2N3055 .75

180 Λ 1/4	20K Λ 1/4
330 Λ 1/4	22K Λ 1/4
330 Λ 1/8	27K Λ 1/4
470 Λ 1/4	33K Λ 1/4
680 Λ 1/4	39K Λ 1/2
1K 1/4	43K Λ 1/4
1.2K Λ 1/4	47K Λ 1/4
2.2K Λ 1/4	56K Λ 1/4
3.3K Λ 1/4	82K Λ 1/4
3.9K Λ 1/4	100K Λ 1/4
4.7K Λ 1/4	150K Λ 1/4
6.8K Λ 1/4	220K Λ 1/4

3N201
 PROTECTED DUAL GATE N-CHANNEL FET FOR LOW NOISE, VHF PREAMP APPLICATIONS - **Only \$.80**

BRIDGES

1 amp 50V **\$.89**
 10 amp 50V **1.29**
 25 amp 50V **1.49**

All resistors are PC Lead but are not pull offs
 5% - 100 min. order Each value
 No Mix - 99¢ 100

HARDWARE

New, includes 2-56, 4-40, 6-32 and 8-32 screws and nuts. A very useable selection $\frac{1}{2}$ pound **\$1.50**
 1 pound **2.60**

ELECTROLYTIC CAPS

2200 UF 35VDC Upright PC Lead **\$.29**
 1000 UF 35VDC Upright PC Lead **\$.29**

FCM 7010
 4 DIGIT DIRECT DRIVE RADIO ALARM CHIP SIMILAR TO MK50380 **ONLY \$4.95**

DIODES BY MOTOROLA
 2-1/2 AMP 1000 VOLT
 8 for \$1.00
 Limited Quantity

LM309K **\$1.50**
 NE565 **1.00**
 NE555 **.45**
 LM3900 **.35**

PROJECT CASES

(Order by number)

CASE 1
 H-1 1/2"
 W-3"
 L-4 3/8"  **\$1.40**

CASE 3
 H-2 1/2" **\$3.40**
 W-7"
 L-4"
 Slope Front - 1/2"



CASE 2
 H-2" **\$3.00**
 W-4 7/8"
 L-3 1/2"
 Slope Front - 1/4"

FOR CUSTOM BUILT CASES, CALL OUR TOLL FREE NUMBER. Also ask about our liberal quantity discounts.

CASE 4
 H-1 7/8"
 W-4 3/8"
 L-3"



CASE 5
 H-1 1/2" **\$.99**
 W-2 7/8"
 L-2 1/2"

FND 359
 COMMON CATHODE DIRECT REPLACEMENT FOR FND 70 BUT LARGER .40 IN. CHARACTER **Only \$.90**
 6 for **\$4.95**

FCS 8000
 COMMON CATHODE 12 HOUR 3-1/2 DIGIT ARRAY Includes AM/PM Indicator and Colon. .80 in. character **\$4.95**

Special CD4013AE By RCA
 5 for \$1.00 100% PRIME

TTL

7400 .19	7425 .30	7454 .19	74100 \$1.
7401 .19	7426 .27	7470 .38	74123 .65
7402 .19	7427 .19	7472 .25	74125 .47
7403 .19	7432 .34	7473 .25	74141 .75
74L04 .29	7437 .39	7474 .39	74145 \$1.
7404 .19	7438 .39	7475 .59	74154 \$1.
7406 .29	7440 .19	7480 .49	74161 .95
7408 .19	7442 .65	7485 .95	74163 \$1.10
7409 .19	7443 .65	7490 .75	74164 \$1.10
7410 .19	7444 .69	7491 .75	74174 .95
7411 .29	7446 .89	7492 .75	74175 \$1.80
7413 .50	7447 .85	7493 .70	74180 .80
7420 .19	7450 .24	7494 .95	74191 \$1.25
7430 .19	7451 .19	7495 .75	74192 \$1.25
7421 .19	7453 .19	7496 .89	74193 \$1.
7423 .39		74195 .69	

100% GUARANTEED! OR YOUR MONEY BACK.

GUARANTEED! **CMOS** 100% PRIME!

CD4001 .23	CD4017 1.00	CD4030 .40	CD4056 1.80
CD4002 .23	CD4018 1.20	CD4035 1.24	CD4060 1.45
CD4007 .23	CD4019 .40	CD4040 1.35	CD4066 .85
CD4009 .53	CD4021 1.20	CD4041 .85	CD4071 .23
CD4010 .49	CD4022 .95	CD4043 .73	CD4076 .25
CD4011 .23	CD4023 .23	CD4044 .50	CD4098 .65
CD4012 .23	CD4024 .87	CD4049 .55	CD4512 .30
CD4013 .45	CD4025 .23	CD4050 .50	CD4516 .75
CD4014 1.30	CD4027 .53	CD4051 1.45	CD4518 .60
CD4015 1.10	CD4028 .90	CD4052 1.25	CD4520 .60
CD4016 .49	CD4029 1.20	CD4053 2.25	CD4911 .30

CALL OUR TOLL FREE NUMBER 1-800-527-2304 FOR QUANTITY DISCOUNT INFORMATION

VOICE ACTIVATED SWITCH



99c
Reg 1.98

Activates devices such as lights, tape recorders etc. Comes with 5' leads 3 x 1. Operates on 4.5 VDC. Shpg wt 1/2 lb.

XM-556

8-TRACK Blank Tape



39c
Reg. 69c

40-Min. Blank tapes for quality reproduction. Just the right length for recording most LP's etc. Shpg wt 1/2 lb.

TA-907

ELECTROLYTIC CAPACITOR KIT



1.70
REG. \$5

Package of 50 axial and radial lead types. Low voltage, high capacity types. Shpg wt 1 lb.

CD-407

SOLDERING IRON



1.79
REG. 3.29

Easy to use pencil-tip iron for those delicate soldering jobs. Reaches temperature to 250° 9/16" long 117 VAC. Shpg wt 1/4 lb.

TL-448

HARDWARE AND COMPONENTS

1/4 RPM Timing Motor 115V AC	MO-277	Reg. 89	39
1 RPM Timing Motor 115V AC	MO-289	Reg. 89	39
3.6V DC Hobby Motors Kit of 5	MO-333	Reg. 2.00	59
2 Speed Motor 115V AC	MO-336	Reg. 3.00	99
3600 RPM Motor 115V AC	MO-361	Reg. 2.98	99
4000 RPM Appliance Motor 115V AC	MO-395	Reg. 1.79	79
6V Panel Lamp 1-Red 1-Green	PL-065	Reg. 89	59
6V 30 ma Lamp w/Leads Pkg 2	PL-270	Reg. 69	59
6V Mini-Screw Base Bulb, Pkg 2	PL-271	Reg. 89	59
12V Mini-Screw Base Bulb, Pkg 2	PL-272	Reg. 1.19	59
12V Bipin Mini Bulbs, Pkg 2	PL-273	Reg. 99	59
TV Cheater Cord, Pkg of 2	WW-061	Reg. 1.30	50
Terminal Strips, Pkg 40 Ass'd	XM-501	Reg. 3.79	1.19
25 B474 Output Transistor	TR-174	Reg. 99	39
Fairchild 703 Type IC	TR-293	Reg. 99	39
Fairchild 717 Type IC	TR-294	Reg. 1.19	50
IC Grab Bag, 10 Ass'd Types	TR-422	Reg. 6.00	2.99
Calculator IC Chip, Nortec 4202	TR-424	Reg. 2.69	90
SCR Grab Bag, 25 Ass'd Types	TR-446	Reg. 90	49
Cadmium Photo Cells, Pkg of 2	TR-512	Reg. 1.29	59
Motorola Amplifier IC, 8 Pin D.I.P	TR-513	Reg. 49	29
Aluminum Heat Sink 1 3/4 x 1/2 x 1/2	XM-027	Reg. 6.00	1.49
12 Digit Calculator IC	XM-330	Reg. 6.00	1.29
20 Key Calculator Keyboard	XM-339	Reg. 2.69	1.39
3 7 Seg. L.E.D. Green, Comm. A	XM-341	Reg. 1.99	1.39
3 7 Seg. L.E.D. Yellow, Comm. A	XM-342	Reg. 2.00	1.19
3 7 Seg. L.E.D. Red, Comm. A	XM-370	Reg. 1.49	.79
Sperry 9 Digit Display	XM-399	Reg. 2.00	.99
3 7 Seg. L.E.D. Red, Comm. K	XM-414	Reg. 5.00	1.00
11 Calculator Keyboard, 20 Key	XM-523	Reg. 1.29	.59
16 Key Switch Pad, Less Keys	XM-524	Reg. 49	.69
23 Key Switch Pad, Less Keys	XM-525	Reg. 98	1.00
Calculator Switch, Pkg of 20 Ass'd	XM-538	Reg. 2.19	1.49
455 KHz IF Transformer, Pair	LL-083	Reg. 1.79	.99
Toggle Switch Kit, Pkg 3 Ass'd	SW-154	Reg. 1.29	.69
Mini Toggle Switch D.P.D.T. 3A	SW-406	Reg. 1.89	1.09
See-Saw Rocker Switch D.P.D.T. 3A	SW-423	Reg. 29	.19
Center-Off Mini Toggle S.P.D.T. 3A	SW-460	Reg. 1.69	.49
Three Level Push Switch, 8A	SW-586	Reg. 0.00	.99
Mercury Switch, S.P.D.T. 5A	SW-641	Reg. 1.59	.69
117 V AC Relay, Mini, S.P.D.T. 2A	SW-773	Reg. 1.29	.79
Mini Rocker Switch, S.P.S.T. 1A	SW-814	Reg. 3.00	.90
Leaf Switch, S.P.D.T. 5A, Pkg 2	SW-838	Reg. 2.00	.69
Heavy Duty Toggle, 3.P.D.T. 10A	SW-840	Reg. 1.20	.59
117 V AC Solenoid, 1 Travel	SW-846	Reg. 1.29	.79
Slide Switch, D.P.3.T. Pkg of 2	SW-850	Reg. 3.00	.90
11 PC Slide Switch Kit	TF-348	Reg. 79	.60
6 & 12V Trans, 117V PRI, 5A SEC	TF-050	Reg. 2.00	1.29
12 & 10V Trans, 117V PRI, 2A SEC	TT-076		

FREE CATALOG



260 SO. FORGE ST.
DEPT. LU, AKRON, OHIO 44327

NAME _____

ADDRESS _____ CITY STATE _____

ZIP _____ Send Olson Catalog

Free PA Catalog _____ Ship The Following _____

How Many	Stock Number	Description	Price	Total

ENCLOSE POSTAGE AND SALES TAX

CIRCLE 19 ON FREE INFORMATION CARD

ACPR Associates
TEST OFFICE INC.
NEWTON MA 02459
603-552-8179

FREE!!! INFORMATION SEND A SELF STAMPED ENVELOPE DON'T DELAY DO IT NOW

FASCINATING microcomputer kits! Build inexpensively ASCII keyboard, paper tape reader, teletypewriter interface, trivoltage PS. Construction manuals \$2 each. 1702A Programming-\$1. Free Catalogue. **MICROTRONICS**, P.O. Box 7454, D101, Menlo Park, CA 94025

KITS, semiconductors, components. Fast delivery, free flyer. **CHIPS ELECTRONICS**, Box 1030, Oakville, Ont., Canada L6J 5E9. U.S. Inquiries.



ORGAN KITS KEYBOARDS

THE ULTIMATE IN DESIGN AND SOUND
DEMO RECORD AND BROCHURE \$1.00

DEVTRONIX ORGAN PRODUCTS, Dept. 4B
5872 Amapola Dr. • San Jose, CA 95129

LINEAR amplifier, 3-30 MHz, 100 watt mobile. Construction plans, \$3.00. **WILSON**, Box 5516-FB, Walnut Creek, CA 94596

TV games kits P/C boards

Send for your information packet today... which also includes circuit functions, component line-up, and accessories. Information Packet \$1.00 (refundable with order).

visulex P.O. Box 4204R Mountain View, CA 94040

MOTHER Board for custom design, compatible with Altair, IMSAI, bus structure 22 slots, w/ power connections \$39.95, 100-pin edge connectors \$4.50 each, Z-80 CPU chip \$69.95, 12VAC 750 ma AC adapters each \$4.50. **NATIONAL DEVELOPMENT**, P.O. Box 10061, Glendale, CA 91209

BUILD YOUR OWN TV CAMERA!

THE ECONOMICAL ANSWER TO HOME MONITORING OF NURSERIES, ENTRANCES, DRIVEWAYS, BUSINESS AND INDUSTRIAL SURVEILLANCE... TV, AMATEUR TV PLUS HUNDREDS OF OTHER APPLICATIONS. MODEL: ATVA, SERIES D - KIT FORM \$185 ASSEMBLED \$215. SOLID-STATE WORKS ON ANY TV SET. OPTIONAL SOUND KIT \$29.95. PHONE OR WRITE for catalog. Dial 402-987-3771

BOX 453-RE **ATV Research** DAKOTA CITY, NE 68731

FUNCTION generator PCB using 8038 IC. Provisions for power supplies; variable offset, duty, amplitude, frequency. Complete instructions. \$7.00. **TELUS ELECTRONICS**, 77 Leacock Drive, Ottawa, Canada K2K 1S5. US inquiries invited.

SHOOT OUT
JUST ONE OF THE 16 GAMES YOU CAN PLAY WITH OUR NEW INCREDIBLE HAND HELD ELECTRONIC GAME. SATISFACTION GUARANTEED. ASSEMBLED & PPD. \$8.95
KIT \$6.95
INTERFAB, 27959T CABOT RD, LAGUNA NIGUEL, CA 92677

DECORATOR telephone kits. Over 50 styles and colors. Catalog 50¢. **PHONE FACTORY KITS**, RE016, Box 43147, Las Vegas, NV 89104

FOR SALE

RECONDITIONED test equipment \$0.50 for catalog. **WALTER'S TEST EQUIPMENT**, 2697 Nickel, San Pablo, CA 94806

SEMICONDUCTOR and parts literature. J. & J. **ELECTRONICS**, Box 1437R, Winnipeg, Manitoba, Canada. U.S. Inquiries Invited.

SURPRISE! Build inexpensively, the most unusual test instruments, futuristic gadgets using numerical readouts! Catalogue free! **GBS**, Box 100B, Greenbank, WV 24944

CANADIAN discount and factory clearouts catalog. Top brand stereo equipment, calculators, test gear, CB & communications, telephones. Factory dumps—government surplus. Amazing bargains. Unusual items. Rush \$1. **ETCO-RE**, 521 5th Ave., NYC, 10017

EC-101 CURVE TRACER
STILL BY FAR THE LOWEST COST FULL FUNCTION CURVE TRACER ON THE MARKET. ATTACHES TO YOUR SCOP IN SECONDS. USED BY EDUCATORS, PROFESSIONALS AND HOBBYISTS ALL OVER THE WORLD. 30 DAY MONEY BACK GUARANTEE.

lab science
\$39.50
ADD \$2.95 P&H
\$39.50
ADD 3.1% SALES TAX

PO BOX 1972, BOULDER, COLO. 80306

NEW Canadian Magazine, "Electronics Workshop", \$5.00 yearly, sample \$1.00. **ETHCO**, Box 741 "A", Montreal, Canada.

FREE catalog IC's, Semi's. **CORONET ELECTRONICS**, 649A Notre Dame W., Montreal, Que. Canada, H3C-1H8. US Inquiries.

RADIO & TV tubes 36¢ each. One year guaranteed. Plus many unusual electronic bargains. Free catalog. **CORNELL**, 4217-E University, San Diego, CA 92105

Govt. SURPLUS ELECTRONIC EQUIPMENT CATALOG

New ITEMS... New BARGAINS!
FREE UPON REQUEST!
If you haven't received our new Catalog, write for free copy today. Address: Dept. RE

FAIR RADIO SALES
1016 E. EUREKA • Box 1105 • LIMA, OHIO • 45802

MANUALS for Govt. surplus radios, test sets, scopes. List 50¢ (coin). **BOOKS**, 7218 Roanne Drive, Washington, DC 20021

DESCRAMBLERS: Several professional models that work with all scanners. Tone encoders/decoders. Scanmate, AAPP, radar detectors. Big Ears, alarms, books, kits, parts. Catalog 25 cents. **KRYSTAL KITS**, Box 445, Bentonville, AR 72712

NON semi surplus. Monthly picture flyer. Quality. Low price. Send 25¢. U.S. only. **STARTRONICS**, Box 683, McMinnville, OR 97128

PICTURE TUBE MACHINE
We buy and sell NEW and USED CRT refurbishing machinery. COMPLETE REPAIR-ING. Buy with CONFIDENCE from the ORIGINAL MFGR.

For complete details send name address zip code to
LAKE-SIDE INDUSTRIES
2350 W. Fullerton Ave.
Chicago, Ill 60647
Phone 312-342-3399

FREE catalog. Calculators, digital thermometers, ultrasonics, kits, strobes, Ni-Cads, LED's, transistors, IC's, unique components. **CHANEY'S**, Box 27038, Denver, CO 80227

ELECTRONICS, tools, hobby supplies, specials 2N2222, 3906, 4403 all 6/1.00. Catalog available. **CHEMLAB**, Box 41472-R, Chicago, IL 60641

RCA STEREO SALE

AM-FM MONO TUNER AMP

MODEL RCA 102



3 WATT OUTPUT
All Solid State
With Indicator
And Power Supply
ONLY \$12.00 EACH

ADD \$1.00 POSTAGE FOR THIS ITEM

AM-FM STEREO TUNER AMP

MODEL RCA 103

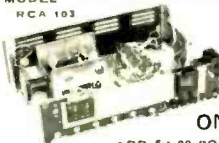

20 WATT PER CHANNEL
2N3055X4
All Solid State
With Dial Indicator
110V AC INPUT

ONLY \$55.00 EACH

ADD \$4.00 POSTAGE FOR THIS ITEM

STEREO AM-FM MUX TUNER AMP

MODEL RCA 104



WITH BUILT IN
8 TRACK PLAYER

USES HITACHI
I.C. POWER AMP
4W PER CHANNEL OUTPUT

All Solid State with a Beautiful Panel.

ONLY \$55.00 EACH

110V AC 50/60 HZ INPUT

ADD \$3.00 POSTAGE TO THIS ITEM

STEREO AM-FM MUX TUNER AMP

MODEL RCA 105

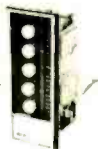

4 WATT PER CHANNEL

All Solid State
With a Vertical Panel

All Brand New with Power Supply

ONLY \$45.00 EACH

110V AC 50/60 HZ INPUT
ADD \$3.00 POSTAGE FOR THIS ITEM

STEREO AM-FM MUX TUNER AMP

MODEL RCA 106



5 Watt Per Channel Output
Uses Sanyo STK011
Hybrid Power Amp
and RCA Hybrid Drivers.

Two separated dials
for AM and FM with slide volume control and signal indicator.

ONLY \$40.00 EACH

110V AC 50/60 HZ INPUT

ADD \$3.00 POSTAGE FOR THIS ITEM

8 TRACK STEREO TAPE PLAYERS

MODEL RCA 107



Complete Stereo Players
With Built-In
Pre-Amp

110V AC 50/60 HZ INPUT
ONLY \$7.50 EACH

ADD \$1.50 POSTAGE FOR THIS ITEM

RCA FM-AM MUX TUNER

MODEL RCA 109



Without Case
(Power Supply
Not Included)

Special Price \$16.00 each

RCA 12 WATT PER CHANNEL FM-AM MUX TUNER AMP

MODEL RCA 108



All brand new
but no case.

Special Price \$35.00 each

ADD \$4.00 POSTAGE FOR THIS ITEM

COMPLETE ALARM CLOCK

*4 Digits 0.5" LED with brightness control
*12 Hour display with AM/PM indication
*True 24 hour alarm with repeatable snooze
*Power failure indication for power interrupt



MODEL EC 400

(Not A Kit)

Only \$22.50

ON SALE \$17.50 ea.

CLOCK KIT MOST POPULAR MM5314 KIT



WITH A NEW CASE!!

Features: 12/24 Hour Display

50/60 HZ Input 6 Digits Readout

Kit Includes: Grey Color Plastic Case
MM5314 Clock Chip PC Boards and Trans
former, 6 Green Color 0.3" Tube Readouts.
All other transistor Drivers and other Components.

Special Only \$19.95 ea.

5W AUDIO AMP KIT

USE 2 LM380

With Volume Control

POWER SUPPLY 6VDC

only \$5.00 ea.



3 AMP POWER SUPPLY

UA723 REGULATED

Output 5V and 12V

Input 110AC

only \$19.50



*Postage for this item \$2.50

ELECTRONIC SWITCH KIT

CONDENSER TYPE

Touch on Touch Off

use 7473 I.C.
and 12V relay

\$5.50 each

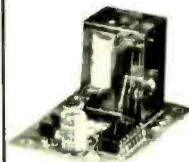

FM WIRELESS MIC KIT

Transmit range up to 500 ft.

Easy to assemble

\$4.50 each



Sub-Mini Size

Condenser Microphone

\$2.50 each



ASCII KEYBOARD ENCODER CHIP

G1AY-5-3600

40 pin DIP package, 4 level,

10 BITS per level, encoding

for up to 90 keys. Latched

data outputs and control signal

output, TTL compatibility

for all controls.

WITH DATA ONLY \$15.00 EACH



COMPUTER KEYBOARDS

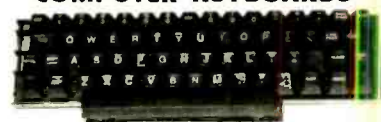

Standard Teletype Keyboards with gold plated contact switches. All switches are independent and allow you to connect into any form of output.

63 Keys - 19.50
60 Keys - 14.50

SPECIAL THIS MONTH

CPU	8080A	\$19.50
UART	TR1402A	\$10.50
PROMS	1702A	\$11.50
ROM'S	2513	\$ 9.00
RAM'S	1103	\$ 1.00
RAM'S	2102	\$ 1.90

LCD 0.3" 8 DIGITS DISPLAY



ONLY \$1.75 EACH

SAE DIP SWITCHES



Part No 1004 692 4 SPST SW
1008 692 8 SPST SW

4 Toggle SPST Switches or a Mini-DIP
18 units Only \$1.50 ea.
8 Toggle SPST Switches or a DIP
16 units Only \$2.60 ea.

SUBMINIATURES TOGGLE SWITCHES



SPDT On/Off \$1.30 ea.
DPDT On/Off \$1.50 ea.
3PDT On/Off \$1.70 ea.

Mini Size Rocker Type
Also Available at the Special Price

ECCO BCD THUMBWHEEL SWITCHES



8 positions \$1.50 ea.
10 positions \$2.50 ea.
12 positions \$2.00 ea.

PUSH-BUTTON SWITCH



RED COLOR N/O/FEN 4/\$1.00
BLACK COLOR N/C/C/O/E 2/\$1.00
LARGE TYPE AVAILABLE

SOLID STATE ELECTRONIC BUZZER



Mini Size 1 x 5/8 x 1/4
Supply voltage 1.5 - 12V
Ideal for Alarm or Tone Indicator
\$1.50 each or 2/\$2.50

12 VDC Relay

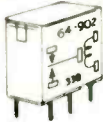

SPDT 4 amp
\$1.25 ea.

MINI SIZE 12V RELAY



DTDT 500
\$1.40 ea.

NI-CD RECHARGEABLE BATTERIES



AA SIZE, 1.2V \$1.25 each
C SIZE, 1.2V \$1.50 each
F SIZE, 1.2V \$2.50 each

ALL GUARANTEED GOOD

AUTO ALARM KIT



The Com-Lighter Auto Alarm is an electronic, self controlled auto protection system, normally installed within the glove box of an automobile.

Two minutes after turning off the ignition, the alarm automatically turns itself "on". When the auto is reentered, the horn will sound after a 10-45 second entry delay. The automobile owner, by inserting the ignition key, will activate the alarm. Once activated, the alarm will sound for two minutes before automatically turning off. The alarm then resets and is ready to again protect the vehicle from unwanted entry.

FEATURES: Simple installation. 5 wires. Automatically turns on when auto is parked. Adjustable entry time. Extended exit time to allow for unattended exit from vehicle. Numerous applications include protection of boats, campers, trailers, motorcycles, trucks. Cannot be deactivated by "hot wiring" an auto. Cannot be turned off without ignition key. Negative-ground only.

ONLY \$10.00 per kit. Completed Unit \$16.00

19 KEY ALPHANUMERIC KEYBOARD



STANDARD SIZE
KEY TOPS
WITH
UNENCODED
SPST KEYS
ONLY \$9.95 EACH

50 U.A. PANEL METER



First designed for metal Finger Scaled from 0 - 10 but can be etched and your own scale cut on top. Brand new in box. Only \$3.80 ea.

150UA METER

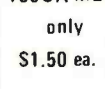

only \$1.50 ea.

QUAD VOLUME CONTROL



4 100K Volume pot in one unit vary resistance proportional to the angle of the stick. Perfect for electronic games or model remote control.
Knob for Joystick 50¢ ea.

MINIMUM ORDER \$10.00. California residents add 6% sales tax and 1.50 to cover postage and handling. Out of state add 2.50 for postage. Overseas countries add 10% of total order for postage. SEND CHECK OR MONEY ORDER TO



FORMULA INTERNATIONAL INC.

12603 CRENSHAW BOULEVARD • HAWTHORNE, CALIFORNIA 90250

For more information please call (213) 679-5162

STORE HOURS 10-7 Monday - Saturday

2/77

SEND FOR
**FREE CATALOG
WITH ALMOST
3000 ITEMS**

INCLUDING
B&K, EICO, RCA,
FLUKE, SENCORE,
SIMPSON, HICKOK

and LEADER
plus a complete line
of tubes, tools and
electronic supplies
at prices you won't
believe.

FORDHAM

RADIO SUPPLY CO., INC.
855R Conklin St. Farmingdale, N.Y. 11735
Tel (516) 752-0050

CIRCLE 59 ON FREE INFORMATION CARD

GODBOUT

BILL GODBOUT ELECTRONICS
BOX 2355, OAKLAND AIRPORT, CA 94614

ALL items on this page while they last and are subject to prior sale.

LIMITED QUANTITY SPECIALS

LED mounting gizmo --- press fits into 1/8" panel or glue to thinner metal. Fits standard size LED (no minis or jumbos)...10/\$1



SUBMIT PC MOUNT SLIDE SWITCH
Center off SPDT. Only 5/8" by 3/4" with pins on 1/8" centers.
A VERY GOOD BUY..... 10/\$2

THE REAL TITLING FROM MONSANTO:
MAN-10A seven segment readout with bar, not dot, LEDs. Limit 8 to a customer. Digit is .27" high.....95¢ EACH



HOUSE NUMBER ICS

The parts below include pinout and data---

988 ONE-SHOT similar to 74121.....4/\$1.00

SN14058 DUAL 4 INPUT AND GATE with open collector or totem pole output.....7/\$1.00

C4347 TRIPLE 3 INPUT NOR GATE same as SP370A.....6/\$1.00

7472 FLIP FLOP house numbered.....5/\$1.00

INTEL 3101-4 BIPOLAR 4X16 RAM super fast, same pinout as 74S189. TTL, single +5 Volt supply.....\$1.50 each

75325.....3/\$2.00

SILICON SIGNAL/SWITCHING DIODES.....35/\$2.00

SEND FOR OUR FLYER

TERMS add 50¢ to orders under \$10. No COD. Cal res add tax. Mastercharge*/BankAmericard* call (415) 562-0636, 24 hours. SEND FOR OUR FLYER!

RADIO-ELECTRONICS

112 CIRCLE 30 ON FREE INFORMATION CARD

SUPER Specials

ZENITH
COLOR FLYBACK S-964530-2 \$5.95
VOLTAGE TRIPLER-212-109 \$2.95 Ea.
VOLTAGE TRIPLER-212-139 \$6.95 Ea.
212-72-CONV. DIODE PAK 2 for \$1.00
VIDEO IF STRIP-150-115 \$7.95
SPACE COMMAND "600" HAND REMOTE \$8.00
HV STICK 45KV (RECTIFIER) \$3.95 Ea.
15 MEG. FOCUS POTS 2 for \$1.00
COLOR YOKE S-89750 (Y162) \$7.95

COLOR FLYBACKS--(SPECIAL DEAL)
RCA 136640 \$2.95
RCA 137545 \$2.95
PHILCO 32-10132-1 \$2.95
MAGNAVOX 361374 \$5.95
JAP FLYBACK (USED OLYMPIC. ETC.) 2 for \$1.98

TUNERS--NEW
PHILCO TRANSISTOR 76-14340-1 \$3.95
SYLVANIA 5GJ7-3HQ5 \$3.50
G.I.-6GS7-6HA5 2 for \$5.00
CURT. MATHES SERIES 6CG8 3GK5 \$3.95
6-ASST'D UHF TUNERS \$3.00
UHF TUNER DETENT TYPE (DIAL ASSEMBLY) \$1.00 Ea.

COLOR YOKES
REPL. DY95AC-Y109 (LESS COVER) \$5.95
JAP YOKES (USED SEVERAL SETS) \$4.00
GEN. ELECT. 76X8 \$2.00
70" (21" ROUND CRT) ONLY \$2.95 Ea.
GRAB BAG-4 B/W FLYBACK XFMRs (JAD) \$2.00

DIODES--RECTIFIERS
100-2.5 AMP. 1000 PIV \$9.95
10-15KV FOCUS RECTIFIERS \$4.50
5-8KV FOCUS RECT (G.E.) \$2.00
5-BOOST RECT (G.E.) \$2.00
5-G.E. BFP-004 DAMPERS (4KV) \$2.00
10-DUAL DIODES (COMMON CATH.) BULK \$2.95
20-IN60 CRYSTAL DIODES \$2.25
VOLT. TRIP REPL ECG 500 \$6.95 Ea.
2-SHUNT REG HOODS (6BK4. ETC.) \$1.19
50 ASST'D CONTROLS \$2.00
200 RESISTORS (CUT LEADS) \$1.29
50 ASST'D WIRE WOUND RESISTORS \$1.98
50 ASST'D FILTERS (TRANS. WORK) \$4.95
25 ASST'D FILTERS (CANS) \$4.95
25 ASST'D FILTERS (AXIAL LEADS) \$4.95
6 ASST'D ALIGN. TOOLS \$1.00
6 ASST'D FOCUS SOCKETS (2AV2-1V2) \$1.19
4-COLOR CRT HARNES (19"23"25") \$1.19
6 ASST'D CIRCUIT BREAKERS \$3.00
66 MEG. HV RESISTORS (IRC) 4 for \$1.19
50 FT. SPEAKER WIRE \$.89
100 FT. SPEAKER WIRE \$1.79

ANTENNA EQUIPMENT
6 ANT. CLOTHESPINS \$1.19
2-2 SET COUPLERS \$3.00
2-4 SET COUPLERS \$4.50
6-75-300 OHM MATCHING TRANS \$5.95
UHF-LDOP ANT. 18" LEAD 6 for \$1.00
BEHIND SET ANT. (UNIVERSAL) 2 for \$5.00
1000 FT-300 OHM FOAM 7 Str. 100 Mil \$24.95
1000 FT. 59 U COAX (BLACK) ONLY \$39.95
VHF/UHF 300 OHM SPLITTER \$1.49
VHF/UHF/FM-300 OHM SPLITTER \$1.98

CONDENSERS AXIAL LEADS
1 Mfd. 50 Volts \$1.00
500 MFD. 25 VOLTS (P.C.) 5 for \$1.00
50-30 MFD. 150 VOLTS 4 for \$1.00
500 MFD. 50 VOLTS 6 for \$2.49
200 MFD. 175 VOLTS 2 for \$1.59

CONDENSERS CANS
500 MFD.-200 VOLTS 3 for \$2.19
500-500-100 MFD.-50 VOLTS 3 for \$1.98
250-100 MFD. 350 VOLTS 3 for \$2.19
200-20-500 MFD. 200 V. 150 Mid. 350V 3 for \$2.19
300-300 100-100 Mid. 150 V. 6 for \$2.69
80 Mid. 175 V. 10-40 Mfd. 150V (1") 3 for \$1.00
400-400-40 Mid. 150 V. 500 Mid. 35V 3 for \$2.19

AUDIO EQUIPMENT
4X6-16 OHM SPEAKER \$1.29
4" SQ. SPEAKER \$7.95 Ea.
3" SQ. SPEAKER \$7.95 Ea.
2" SQ. SPEAKER \$7.95 Ea.
5 1/2"-5 OZ. Mag. \$3.95
6" ROUND SPEAKER \$1.59
3-C-60 IRISH CASSETTE \$1.49
3-C-90-IRISH CASSETTE \$1.98
UNDER PILLOW SPEAKER 6FT /With PLUG \$5.59
MONO TONEARMS \$1.69 Ea.
VM-45 ADAPTOR (FLAT) \$5.95 Ea.
89T. CARTRIDGE \$1.29 Ea.
8T SONOTONE (BULK) \$1.00
BSR-8TCS-CART. & NEEDLE (BULK) \$1.00
25 ASST'D NEEDLES (EXCELLENT DEAL) \$4.95
CASSETTE MIKE 200 OHM IMPED. \$1.99

REPL. DIAMOND NEEDLES
SHURE-N-3D \$2.95
SHURE-N-44 \$2.95 Ea.
SHURE-N-75 \$2.95
SHURE-N-91 \$2.95
PICKERING V.15-ORANGE \$2.95
PICKERING V.15 GREY \$2.95
CARD 12 FORK NEEDLES \$2.39

RECORDING TAPE
1200 FT. 7" REEL \$2.19
1800 FT. 7" REEL \$2.69
600 FT. 5" REEL \$1.29
900 FT. 5" REEL \$1.79
1200 FT. 5" REEL \$2.98
CASSETTE HEAD CLEANER \$6.69 Ea.
8 TRACK HEAD CLEANER \$7.95 Ea.
CR-200 70% COLOR BOOSTER 3 for \$11.50
CRT 250 90% COLOR BOOSTER 3 for \$12.50
SDNY COLOR BOOSTER \$3.50 Ea.
SBE BRUTE CB LIST \$144.95--YOUR COST \$89.95
SBE FORMULA D 26CB ONLY \$99.95
SBE FORMULA D "TOUCH COM" \$189.98
SBE CATALINA III-SBE 29CB \$89.95
SBE1-SM-SCANNER LO. 30-51 Mhz. HI. 144-171 Mhz

CB-SWR/FS/POWER METER-SALE PRICE \$19.95
PL 259 10 for \$4.95
CB-LOW IMPED. HAND MIKE ONLY \$4.95
CB-HOT LINE FILTER KIT \$1.69
3 PIN MIKE CONNECTOR (FEMALE) \$1.00
4 PIN MIKE CONNECTOR (FEMALE) \$1.00
6 FT. CHEATER WITH CLIP 3 for \$1.39
6 FT. CHEATER WITH CLIP (POLAR) 3 for \$1.49
6 FT. CHEATER CORD (SONY) 3 for \$1.69
6 FT. CHEATER ZENITH 3 for \$1.69
6 FT. CHEATER ZENITH (POLAR) 3 for \$1.69

COLOR IC CHIPS
REPL. ZENITH 221-62 4 for \$5.00
REPL. ZENITH 221-46-221-51 4 for \$5.00
REPL. ZENITH 221-42 4 for \$5.00
REPL. ZENITH 221-69 4 for \$5.00
REPL. ECG 715 4 for \$5.00
REPL. ECG 748 4 for \$5.00
REPL. ECG 749 4 for \$5.00
FINCO 4 SET BDOSTER 65-1 (TUBE) \$31.95
FINCO AUTO FM ANT. BOOSTER \$15.95
FINCO SIGNAL 23 CB CONVERT \$24.95
TV AMP. ONE SET 75 OHM BOOSTER \$11.95
TV AMP. FOUR SET 75 OHM BOOSTER \$15.95
30 WATT PENCIL SOLD IRON \$1.99
4 VOLT. UNIV. AC ADAPTOR ONLY \$3.29
MURA DX 2000 BASE STA. MIKE ONLY \$19.95
40 KV HV PROBE CURRENT & VOLT. SALE \$26.95
15 FT. REMOTE ON/OFF CORD. \$1.69 Ea.
STEREO CASSETTE MIKES ONLY \$9.95 Pr.
12 VOLT REG. POWER SUPPLY. 7 A. SURGE \$18.95
RUBBER DUCKIE SCANNER ANT. 150-162 Mhz \$4.25
RUBBER DUCKIE SCANNER ANT. 450-470 Mhz \$4.25
WELLER 8200 PK KIT 100 /140 WATTS \$10.95
WELLER WC 100 CORDLESS SOLD. IRON. \$13.95
WAHL CORDLESS SOLD IRON =7500 \$13.95

• DIST. FOR B/K TEST EQUIPMENT • DIST. FOR SBE-CB-RADIOS
SEND FOR FREE CATALOG

• TUBES UP TO 80% OFF • MINIMUM ORDER \$50.00
Orders under \$50.00--\$2.00 shipping & handling

SEND CHECK
OR M.O.

TV TECH SPECIALS

P.O. BOX 603, KINGS PARK, L.I., NEW YORK 11754
PHONE 516-269-0805

CIRCLE 64 ON FREE INFORMATION CARD

DIGI-KEY CORPORATION
Quality Electronic Components
Double-Digit Discounts
Save You Even More

2102-1 \$1.99	8080A \$24.95	LM3909 69¢
-------------------------	-------------------------	----------------------

NATIONAL SEMICONDUCTOR CLOCK MODULES

MA1010A 12 Hour (AM-PM) Version . . . \$13.00
MA1010C 24 Hour Version . . . \$13.00



MA1002A 12 Hour (AM-PM) Version . . . \$10.50
MA1002C 24 Hour Version . . . \$10.50

0.5" High LED Digits



Special transformer and 6 switches.
when ordered with module add \$3.45.

0.84" High LED Digits

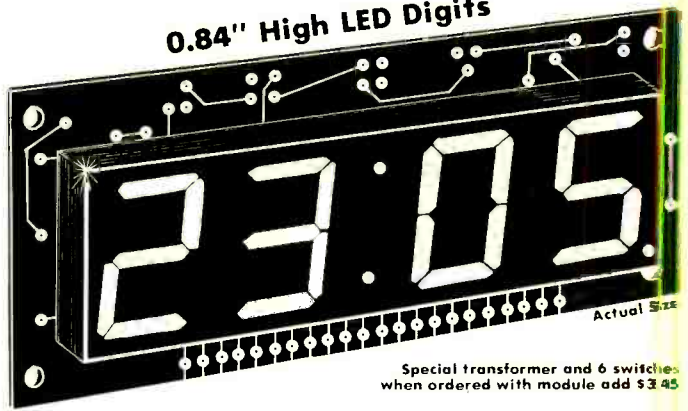

Special transformer and 6 switches.
when ordered with module add \$3.45

Hobby-Wrap-30 \$5.95

Strips, Wraps and Unwraps 30 ga. wire on standard wire wrapping pins

STRIP WRAP UNWRAP

MA1002 & MA1010 Series Electronic Clock Modules

The MA1002 & MA1010 Series Electronic Clock Modules are assembled and pretested modules which combine a monolithic MOS-LSI integrated clock circuit, 4-digit LED display, power supply and other associated discrete components on a single printed circuit board to form a complete electronic clock module. The user need add only a transformer and switches to construct a digital clock for application in clock-radios, alarm or instrument panel clocks. Time-keeping may be from 50 or 60 Hz inputs and 12 or 24 hour display formats may be chosen. Direct LED drive eliminates RF interference. Time setting is made easy through use of "Fast" and "Slow" scanning controls.

The MA1002A and MA1010A have a 12 hour display with an AM and PM indicator. The MA1002C and MA1010C have a 24 hour display.

Features include alarm "on" and "PM" indicators, "sleep" and "snooze" timers and variable brightness control capability. The modules are extremely compact. The MA1002 measuring 1.375" by 3.05", the MA1010 measuring 1.5" by 3.75". This small size is achieved by bonding the IC to the back of the circuit board.

It is highly recommended that the transformer be obtained with the clock module as it is a special dual secondary type not otherwise readily available.

Double Digit Discounts Save You Even More!

ACE201-K \$24.95
1,032 SOLDERLESS PLUG-IN TIE POINTS
CAPACITY: UP TO 12 14-PIN DIP's
TWO 5-way binding posts
Size: 4-9/16" by 7"
Kit form

WIRE WRAPPING WIRE
Red or Black Kynar insulated pre-cut and stripped 30 ga. wire. 1" of insulation is removed from each end.

Insulation Length	No. in. Pkg.	Price per Pkg.
2.0"	100	\$2.50
2.5"	100	\$2.60
3.0"	100	\$2.65
3.5"	100	\$2.70
4.0"	100	\$2.80
4.5"	100	\$2.90
5.0"	100	\$3.00
6.0"	50	\$1.60
7.0"	50	\$1.70
8.0"	50	\$1.80
10.0"	50	\$1.90
15.0"	50	\$2.00
15.0"	50	\$2.50

SLIDE SWITCHES
Single Pole Single Throw
.15 1.20/10 10.00/C
Double Pole Double Throw
.23 2.00/10 19.00/C

BATTERY HOLDERS

1-AA .26¢
2-AA .42¢
1-C .35¢
2-C .42¢
1-D .35¢
2-D .42¢

BISHOP GRAPHICS Printed Circuit Drafting Aids are now available from Digi-Key

RADIAL ELECTROLYTICS

47/50V .08	65/10	22/50V .12	100/10	330/25V .33	1.5/10
1.50V .08	65/10	100/16V .09	.75/10	470/16V .22	1.5/10
2.2/50V .08	65/10	100/10V .10	.77/10	470/25V .33	1.5/10
3.3/50V .08	65/10	100/16V .11	.85/10	470/25V .33	1.5/10
4.7/50V .08	65/10	100/25V .13	1.10/10	1000/10V .33	1.5/10
4.7/50V .08	65/10	100/50V .21	1.71/10	1000/16V .33	1.5/10
6.3/50V .08	65/10	100/10V .13	1.08/10	1000/25V .33	1.5/10
10/25V .08	65/10	220/16V .15	1.16/10	2200/10V .33	1.5/10
10/25V .10	75/10	220/25V .21	1.71/10	2200/16V .33	1.5/10
22/16V .08	67/10	220/50V .29	2.35/10	2200/25V .33	1.5/10
22/25V .09	70/10	330/10V .21	1.66/10	3300/16V .33	1.5/10

INTEGRATED CIRCUITS - TTL, CMOS, LINEAR & MOS

7400 21	7476 32	74181 2.15	4012 23	4520 1.14
7401 21	7485 70	74182 79	4013 20	4527 8.68
7402 21	7486 70	74184 2.19	4014 96	4528 8.68
7403 21	7487 30	74185 2.19	4015 96	4585 1.23
7404 21	7488 89	74188 3.50	4016 40	2102-1
7405 21	7489 28	74189 3.50	4017 1.05	8080A
7406 25	7489 2.19	74190 2.23	4018 105	CA304A
7407 25	7490 54	74191 1.23	4019 23	LM211N
7408 21	7491 70	74192 8.88	4020 1.14	LM3909
7409 21	7492 44	74193 8.88	4021 1.14	LM241A
7410 21	7493 44	74194 8.88	4022 96	LM3401-5
7411 21	7494 70	74195 8.88	4023 23	LM3401-6
7412 21	7495 70	74196 8.88	4024 84	LM3401-8
7413 25	7496 70	74197 8.88	4025 23	LM3401-12
7414 89	74100 1.28	74198 1.49	4026 1.68	LM3401-15
7416 25	74107 30	74199 1.49	4027 40	LM3401-18
7417 25	74109 33	74201 0.9	4028 89	LM3401-24
7420 21	74121 35	74279 55	4029 1.14	LM3909M
7421 25	74122 44	74265 67	4030 23	LM3909N
7423 35	74123 61	74266 67	4033 1.51	MC1456V
7425 35	74125 40	74267 67	4034 3.50	MC1458V
7426 25	74126 40	74268 67	4035 1.14	MC33029
7427 33	74132 70	8093 40	4040 1.14	MS36T
7428 28	74141 88	8094 40	4041 79	MS40L
7430 21	74145 70	8095 67	4042 79	MS55V
7432 25	74147 63	8096 67	4043 70	MS56A
7433 30	74148 1.30	8097 67	4044 70	MS60B
7437 25	74150 1.16	8098 67	4046 86	MS61B
7438 25	74151 70	8099 1.16	4047 40	MS62B
7440 21	74153 67	8540 88	4050 40	MS65A
7442 53	74154 1.03	75451 61	4051 26	MS66V
7443 63	74155 70	75452 61	4052 126	MS67V
7445 70	74156 70	75453 61	4053 126	uA709CV
7446 70	74157 70	75454 61	4066 58	uA710CA
7447 70	74160 88	75459 81	4066 79	uA711CA
7448 70	74161 88	75492 84	4077 23	uA723CA
7450 21	74162 88	75493 1.09	4078 23	uA733CA
7451 21	74163 88	75494 1.19	4078 23	uA741CV
7453 21	74164 96	82525 2.19	4078 23	uA747CA
7454 21	74165 1.15	4000 23	4081 23	uA748CV
7459 21	74166 1.26	4001 23	4082 23	uA750CV
7460 21	74170 2.42	4002 73	4502 79	uA7800CV
7470 30	74173 1.64	4006 1.23	4510 1.14	uA7800CV
7472 30	74174 98	4007 23	4511 1.05	uA7817CV
7473 30	74175 93	4008 79	4514 2.80	uA7817CV
7474 30	74176 79	4009 44	4515 2.80	uA7818CV
7475 49	74177 79	4010 44	4516 1.23	uA7824CV
	74180 70	4011 23	4518 1.14	

WIRE WRAPPING WIRE IN BULK
Red or Black 30 ga. Kynar

100'	\$2.00
500'	\$8.50
1000'	\$15.00

ENTIRE ROCKWELL CALCULATOR LINE ON DISCOUNT IN OUR LATEST CATALOG

PERF BOARD
0.1" spacing between holes
4 1/2" x 6" \$1.71
4 1/2" x 17" \$4.25

TERMINALS
for above perf board
\$1.50/C

LED LAMPS
NSL5053 T-1 1/4 18 \$15/C
NSL5056 T-1 1/4 18 \$15/C

LED DISPLAYS
FND357 CC 375' \$1.75
FND500 CC 500' \$1.75
FND 507 CA 800' \$1.75
FND800 CC 800' \$3.50
FND807 CA 800' \$3.50

AXIAL ELECTROLYTICS

47/10V .11	90/10	33/25V .14	1.15/10	330/16V .33	1.5/10
1.30V .11	90/10	33/50V .19	1.52/10	330/25V .33	1.5/10
3.3/35V .12	95/10	47/16V .14	1.15/10	470/16V .33	1.5/10
3.3/50V .12	100/10	47/25V .17	1.30/10	470/25V .33	1.5/10
4.7/25V .11	100/10	47/50V .21	1.17/10	1000/10V .33	1.5/10
4.7/50V .12	95/10	100/10V .14	1.13/10	1000/16V .33	1.5/10
10/25V .12	100/10	100/15V .20	1.30/10	1000/25V .33	1.5/10
10/50V .14	1.15/10	100/50V .29	2.30/10	2200/10V .33	1.5/10
22/16V .12	100/10	220/10V .18	1.42/10	2200/16V .33	1.5/10
22/25V .13	1.05/10	220/15V .20	1.55/10	2200/25V .33	1.5/10
33/16V .12	1.00/10	220/50V .29	2.35/10	4700/16V .33	1.5/10
		330/10V .21	1.66/10	10000/10V 1.15	1.9/10

MOLEX PINS
Make your own IC sockets on PC board

85/C	8/20" M	38/20" SM	275.00/50M
------	---------	-----------	------------

SILICON DIODES

1N4001	64/10	5.50/C	\$49 M
1N4002	64/10	5.50/C	\$51 M
1N4003	68/10	5.80/C	\$52 M
1N4004	70/10	5.95/C	\$54 M
1N4005	82/10	7.05/C	\$63 M
1N4006	90/10	7.75/C	\$69 M
1N4007	99/10	8.60/C	\$77 M
1N4148	40/10	3.50/C	\$29 M

RESISTOR ASSORTMENTS

5 ea all 10's	1 ea val 10's	5 ea 100's	5 ea 10's	5 ea 10's	\$12.00
5 ea all 10's	1 ea val 10's	5 ea 100's	5 ea 10's	5 ea 10's	\$12.00

1/2 WATT ZENER DIODES

1N5226B 3.3v	15 511 C	1N5226B 7.5v	15 511 C
1N5227B 3.6v	15 511 C	1N5227B 8.2v	15 511 C
1N5228B 3.9v	15 511 C	1N5228B 8.7v	15 511 C
1N5229B 4.3v	15 511 C	1N5229B 9.1v	15 511 C
1N5230B 4.7v	15 511 C	1N5230B 10v	15 511 C
1N5231B 5.1v	15 511 C	1N5231B 10v	15 511 C
1N5232B 5.6v	15 511 C	1N5232B 12v	15 511 C
1N5233B 6.0v	15 511 C	1N5233B 15v	15 511 C
1N5234B 6.2v	15 511 C	1N5234B 15v	15 511 C
1N5235B 6.8v	15 511 C	1N5235B 15v	15 511 C

DATA BOOKS

TTL DATA BOOK
\$4.00

Linear IC's 957 p. \$5.00
CMOS IC's 256 p. \$3.00
Transistors 288 p. \$3.00
Memory IC's 592 p. \$3.00
Interface IC's 464 p. \$4.00
Volt. Regs. 128 p. \$3.00
Linear Appl. 1 432 p. \$4.00
Linear Appl. 2 246 p. \$3.00
Audio 196 p. \$3.00

WIRE-WRAPPING TOOL \$5.95
Wraps, Unwraps & Strips 30 ga. Wire

1/4 & 1/2 WATT 5% CARBON FILM RESISTORS
5¢ each in multiples of 5 per value
\$1.70/100 & \$12.00/1000 of same value
1 ohm thru 1.0 megohm

I.C. SOCKETS

8 Pin Solder	17	1.50/10
14 Pin Solder	20	1.30/10
16 Pin Solder	22	2.10/10
18 Pin Solder	28	2.10/10
24 Pin Solder	38	3.00/10
28 Pin Solder	45	4.20/10
40 Pin Solder	63	6.00/10
8 Pin W-W	24	2.20/10
14 Pin W-W	26	2.20/10
16 Pin W-W	30	2.20/10
18 Pin W-W	30	5.20/10
24 Pin W-W	96	9.10/10
28 Pin W-W	112	10.00/10
40 Pin W-W	92	8.10/10

HARDWARE

2.56 1/4 Screw	99	C 7.20/M
2.56 1/2 Screw	99	C 7.65/M
4.40 1/4 Screw	55	C 3.60/M
4.40 1/2 Screw	60	C 4.05/M
6.32 1/4 Screw	65	C 4.40/M
6.32 1/2 Screw	75	C 4.85/M
8.32 3/8 Screw	99	C 5.85/M
8.32 5/8 Screw	99	C 7.00/M
2.56 Hex Nut	55	C 3.60/M
4.40 Hex Nut	55	C 3.75/M
6.32 Hex Nut	60	C 4.00/M
8.32 Hex Nut	60	C 4.15/M
No. 2 Lockwasher	85	C 5.75/M
No. 4 Lockwasher	45	C 3.00/M
No. 6 Lockwasher	45	C 3.00/M
No. 8 Lockwasher	45	C 3.00/M

DOUBLE-DIGIT DISCOUNT SCHEDULE

Merchandise	Discount	Merchandise	Discount
\$ 0.00-\$24.99	NIL	\$100.00-\$999.99	10% OFF
\$25.00-\$49.99	5%	\$1000.00-\$9999.99	20% OFF
\$50.00-\$99.99	10%	\$10000.00 & up	25% OFF

Then add the Standard Charge & Now
STANDARD SHIPPING/HANDLING CHARGE
If your merchandise total after discount is \$25 or more
\$ 5.00-\$19.99 add \$2.00 \$ 20.00-\$99.99 add \$3.00
\$100.00-\$499.99 add \$4.00 \$ 500.00-\$999.99 add \$5.00
\$1000.00-\$4999.99 add \$6.00 \$ 5000.00-\$9999.99 add \$7.00
\$10000.00-\$49999.99 add \$8.00 \$ 50000.00-\$99999.99 add \$9.00
\$100000.00 & up add \$10.00

COD ORDERS ACCEPTED FOR 30 DAY SHIPMENT - CALL 218-481-6674

DIGI-KEY CORPORATION
Box 677, Thief River Falls, MN 56701 218-481-6674

7400N TTL

SN7400N	16	SN7456A	25	SN74154N	100
SN7401N	16	SN7480N	22	SN74155A	99
SN7402N	21	SN7470N	45	SN74160N	99
SN7403N	16	SN7472N	39	SN74161N	99
SN7404N	16	SN7474N	37	SN74162N	125
SN7405N	24	SN7474N	32	SN74163N	99
SN7406N	20	SN7475N	50	SN74163N	99
SN7407N	29	SN7476N	32	SN74163N	99
SN7408N	21	SN7476N	50	SN74164N	110
SN7409N	25	SN7480N	50	SN74165A	120
SN7410N	18	SN7482N	98	SN74166N	125
SN7411N	30	SN7483N	70	SN74167N	50
SN7412N	33	SN7483N	89	SN74170N	210
SN7413N	27	SN7484N	39	SN74171N	210
SN7414N	70	SN7488N	350	SN74172N	120
SN7416N	35	SN7489N	749	SN74174N	125
SN7417N	35	SN7490N	45	SN74175N	99
SN7420N	21	SN7491N	75	SN74176N	90
SN7421N	21	SN7492N	49	SN74177N	90
SN7422N	19	SN7493N	49	SN74180N	99
SN7423N	37	SN7494N	79	SN74181N	249
SN7424N	29	SN7495N	79	SN74182N	95
SN7426N	37	SN7496N	89	SN74184N	125
SN7427N	37	SN7497N	400	SN74185N	220
SN7429N	42	SN74100N	100	SN74186N	1500
SN7430N	26	SN74107N	39	SN74187N	600
SN7432N	31	SN74107N	39	SN74187N	600
SN7437N	27	SN74112N	39	SN74190N	139
SN7438N	27	SN74123N	50	SN74191N	125
SN7439N	25	SN74125A	60	SN74192N	89
SN7440N	15	SN74125N	60	SN74192N	89
SN7441N	69	SN74125N	60	SN74193N	89
SN7442N	58	SN74126N	95	SN74195N	75
SN7443N	75	SN74141N	115	SN74196N	125
SN7444N	75	SN74142N	400	SN74197N	75
SN7445N	81	SN74142N	450	SN74197N	75
SN7446N	81	SN74144N	450	SN74199N	125
SN7447N	89	SN74145N	115	SN74200N	559
SN7448N	79	SN74147A	235	SN74279N	90
SN7450N	26	SN74148N	200	SN74291N	179
SN7451N	27	SN74150N	100	SN74284N	619
SN7452N	27	SN74151N	79	SN74285N	600
SN7454N	20	SN74153N	89	SN74357N	75

MANY OTHERS AVAILABLE ON REQUEST
20% Discount for 100 Combined 7400's

CMOS

CD4001	15	74C10N	75
CD4001	15	74C10N	65
CD4002	25	74C02N	65
CD4006	250	74C04N	65
CD4007	25	74C04N	65
CD4009	25	74C04N	65
CD4010	59	74C04B	251
CD4011	25	74C04N	275
CD4012	25	74C05N	75
CD4013	47	74C05N	75
CD4016	56	74C51	295
CD4017	135	74C05N	295
CD4019	55	74C05N	325
CD4020	149	74C06N	175
CD4022	125	74C06N	175
CD4023	125	74C07N	45
CD4024	150	74C08N	45
CD4025	69	74C11N	250
CD4026	165	74C56N	309
CD4029	300	74C00N	39
CD4030	65	74C02N	55

LINEAR

LM309H	80	LM310N	295
LM301H	35	LM351N	165
LM301CN	35	LM314N	115
LM302H	75	LM358N	165
LM304H	90	LM370N	115
LM305H	95	LM373N	325
LM309	35	LM377N	400
LM309H	10	LM380N	105
LM309CN	100	LM380N	105
LM309CN	100	LM380N	105
LM309H	110	LM381N	179
LM309K	99	LM382N	179
LM310CN	115	NE510A	600
LM311H	30	NE511H	300
LM318CN	150	NE531H	600
LM319A	130	NE567	600
LM320K-5	35	NE540L	600
LM320K-5-2	35	NE550N	79
LM320K-12	135	NE555V	500
LM320K-15	135	NE561B	500
LM320K-17	175	NE562B	500
LM320T-3-2	175	NE565A	125
LM320T-3	175	NE565N	125
LM320T-12	175	NE566CN	125
LM320T-15	175	NE567H	195
LM320T-18	175	NE567H	195
LM320T-24	175	LM732CN	45
LM323K-5	90	LM709N	29
LM324N	180	LM709N	29
LM339N	170	LM710N	79
LM340K-5	90	LM723N	39
LM340K-6	195	LM723N	39
LM340K-12	195	LM733N	100
LM340K-15	195	LM734N	100
LM340K-18	195	LM741CN	35
LM340K-24	195	LM741CN	35
LM340T-6	175	LM741CN	39
LM340T-8	175	LM747N	79
LM340T-9	175	LM747N	79
LM340T-12	175	LM748N	39
LM340T-15	175	LM748N	39
LM340T-18	175	LM750N	90
LM340T-24	175	LM750N	90
LM350V	100	LM1305N	140
LM351CN	65	LM1307N	65

74LS00 TTL

74LS00	25	74LS151	155
74LS01	25	74LS153	189
74LS02	35	74LS157	155
74LS03	35	74LS162	225
74LS04	35	74LS163	225
74LS05	35	74LS164	195
74LS06	35	74LS165	195
74LS07	35	74LS166	195
74LS08	35	74LS167	195
74LS09	35	74LS168	195
74LS10	35	74LS169	195
74LS11	35	74LS170	195
74LS12	35	74LS171	195
74LS13	35	74LS172	195
74LS14	35	74LS173	195
74LS15	35	74LS174	195
74LS16	35	74LS175	195
74LS17	35	74LS176	195
74LS18	35	74LS177	195
74LS19	35	74LS178	195
74LS20	35	74LS179	195
74LS21	35	74LS180	195
74LS22	35	74LS181	195
74LS23	35	74LS182	195
74LS24	35	74LS183	195
74LS25	35	74LS184	195
74LS26	35	74LS185	195
74LS27	35	74LS186	195
74LS28	35	74LS187	195
74LS29	35	74LS188	195
74LS30	35	74LS189	195
74LS31	35	74LS190	195
74LS32	35	74LS191	195
74LS33	35	74LS192	195
74LS34	35	74LS193	195
74LS35	35	74LS194	195
74LS36	35	74LS195	195
74LS37	35	74LS196	195
74LS38	35	74LS197	195
74LS39	35	74LS198	195
74LS40	35	74LS199	195
74LS41	35	74LS200	195
74LS42	35	74LS201	195
74LS43	35	74LS202	195
74LS44	35	74LS203	195
74LS45	35	74LS204	195
74LS46	35	74LS205	195
74LS47	35	74LS206	195
74LS48	35	74LS207	195
74LS49	35	74LS208	195
74LS50	35	74LS209	195
74LS51	35	74LS210	195
74LS52	35	74LS211	195
74LS53	35	74LS212	195
74LS54	35	74LS213	195
74LS55	35	74LS214	195
74LS56	35	74LS215	195
74LS57	35	74LS216	195
74LS58	35	74LS217	195
74LS59	35	74LS218	195
74LS60	35	74LS219	195
74LS61	35	74LS220	195
74LS62	35	74LS221	195
74LS63	35	74LS222	195
74LS64	35	74LS223	195
74LS65	35	74LS224	195
74LS66	35	74LS225	195
74LS67	35	74LS226	195
74LS68	35	74LS227	195
74LS69	35	74LS228	195
74LS70	35	74LS229	195
74LS71	35	74LS230	195
74LS72	35	74LS231	195
74LS73	35	74LS232	195
74LS74	35	74LS233	195
74LS75	35	74LS234	195
74LS76	35	74LS235	195
74LS77	35	74LS236	195
74LS78	35	74LS237	195
74LS79	35	74LS238	195
74LS80	35	74LS239	195
74LS81	35	74LS240	195
74LS82	35	74LS241	195
74LS83	35	74LS242	195
74LS84	35	74LS243	195
74LS85	35	74LS244	195
74LS86	35	74LS245	195
74LS87	35	74LS246	195
74LS88	35	74LS247	195
74LS89	35	74LS248	195
74LS90	35	74LS249	195
74LS91	35	74LS250	195
74LS92	35	74LS251	195
74LS93	35	74LS252	195
74LS94	35	74LS253	195
74LS95	35	74LS254	195
74LS96	35	74LS255	195
74LS97	35	74LS256	195
74LS98	35	74LS257	195
74LS99	35	74LS258	195
74LS100	35	74LS259	195
74LS101	35	74LS260	195
74LS102	35	74LS261	195
74LS103	35	74LS262	195
74LS104	35	74LS263	195
74LS105	35	74LS264	195
74LS106	35	74LS265	195
74LS107	35	74LS266	195
74LS108	35	74LS267	195
74LS109	35	74LS268	195
74LS110	35	74LS269	195
74LS111	35	74LS270	195
74LS112	35	74LS271	195
74LS113	35	74LS272	195
74LS114	35	74LS273	195
74LS115	35	74LS274	195
74LS116	35	74LS275	195
74LS117	35	74LS276	195
74LS118	35	74LS277	195
74LS119	35	74LS278	195
74LS120	35	74LS279	195
74LS121	35	74LS280	195
74LS122	35	74LS281	195
74LS123	35	74LS282	195
74LS124	35	74LS283	195
74LS125	35	74LS284	195
74LS126	35	74LS285	195
74LS127	35	74LS286	195
74LS128	35	74LS287	195
74LS129	35	74LS288	195
74LS130	35	74LS289	195
74LS131	35	74LS290	195
74LS132	35	74LS291	195
74LS133	35	74LS292	195
74LS134	35	74LS293	195
74LS135	35	74LS294	195
74LS136	35	74LS295	195
74LS137	35	74LS296	195
74LS138	35	74LS297	195
74LS139	35	74LS298	195
74LS140	35	74LS299	195
74LS141	35	74LS300	195
74LS142	35	74LS301	195
74LS143	35	74LS302	195
74LS144	35	74LS303	195
74LS145	35	74LS304	195
74LS146	35	74LS305	195
74LS147	35	74LS306	195
74LS148	35	74LS307	195
74LS149	35	74LS308	195
74LS150	35	74LS309	195
74LS151	35	74LS310	195
74LS152	35	74LS311	195
74LS153	35	74LS312	195
74LS154	35	74LS313	195
74LS155	35	74LS314	195
74LS156	35	74LS315	195
74LS157	35	74LS316	195
74LS158	35	74LS317	195
74LS159	35	74LS318	195
74LS160	35	74LS319	195
74LS161	35	74LS320	195
74LS162	35	74LS321	195

S.D. SALES CO.

P.O. BOX 28810 - C
DALLAS, TEXAS 75228

Z-80 CPU CARD KIT FOR IMSAI/ALTAIR

\$149.^{KIT}

From the same people who brought you the \$89.95 4K RAM kit. We were not the first to introduce an IMSAI/ALTAIR compatible Z-80 card, but we do feel that ours has the best design and quality at the lowest price.

The advanced features of the Z-80 such as an expanded set of 158 instructions, 8080A software compatibility, and operation from a single 5VDC supply, are all well known. What makes our card different is the extra care we took in the hardware design. The CPU card will always stop on an M1 state. We also generate TRUE SYNC on card, to insure that the rest of your system functions properly. Dynamic memory refresh and NMI are brought out for your use. Believe it or not, not all of our competitors have gone to the extra trouble of doing this.

As always, this kit includes all parts, all sockets, and complete instructions for ease of assembly. Because of our past experience with our 4K kit we suggest that you order early. All orders will be shipped on a strict first come basis. Dealers inquiries welcome on this item.

Kit shipped with 2 MHz crystals for existing 500NS memory. Easily modified for faster RAM chips when the prices come down. Z-80 Manual - \$7.50 Separately.

Kit includes Zilog Manual and all parts.

JUMBO
LED
CAR
CLOCK

\$16.95

KIT

You requested it! Our first DC operated clock kit. Professionally engineered from scratch to be a DC operated clock. Not a makeshift kluge as sold by others. Features: Bowmar 4 digit .5 inch LED array, Mostek 50252 super clock chip, on board precision time base, 12 or 24 hour real time format, perfect for cars, boats, vans, etc. Kit contains PC Board and all other parts needed (except case). 50,000 satisfied clock kit customers cannot be wrong!

FOR ALARM OPTION ADD \$1.50
FOR XFMR FOR AC OPERATION ADD \$1.50

60 HZ CRYSTAL TIME BASE FOR DIGITAL CLOCKS S.D. SALES EXCLUSIVE!

KIT FEATURES:

- A. 60HZ output with accuracy comparable to a digital watch.
- B. Directly interfaces with all MOS Clock Chips.
- C. Super low power consumption. (1.5 ma typ.) **\$5.95 or 2/\$10.**
- D. Uses latest MOS 17 stage divider IC.
- E. Eliminates forever the problem of AC line glitches.
- F. Perfect for cars, boats, campers, or even for portable clocks at ham field days.
- G. Small Size, can be used in existing enclosures.

**KIT INCLUDES CRYSTAL, DIVIDER IC, PC BOARD
PLUS ALL OTHER NECESSARY PARTS & SPECS**

50HZ CRYSTAL TIME BASE KIT - \$6.95

All the features of our 60HZ kit but has 50HZ output. For use with clock chips like the 50252 that require 50HZ to give 24 hour time format.

THIS MONTH'S SPECIALS!

- 300.00 KHZ CRYSTAL - \$1.50
- 8080A - CPU CHIP by AMD - \$19.95
- 82S129 - 256 x 4 PROM - \$2.50
- N.S. 8865 OCTAL DARLINGTON DRIVERS 3 for \$1.00
- Z-80 - CPU by ZILOG - \$69.95
- MM5204 - 4K EPROM - \$7.95

Prices in effect this month ONLY!

4K LOW POWER RAM BOARD KIT THE WHOLE WORKS - \$89.95

Imsai and Altair 8080 plug in compatible. Uses low power static 21L02-1 500ns. RAM's, which are included. Fully buffered, drastically reduced power consumption, on board regulated, all sockets and parts included. Premium quality plated thru PC Board.

7400-19c	7411-29c	7451-19c	7490-65c	74153-75c
74LS00-49c	7413-50c	7453-19c	74LS90-95c	74154-1.00
7402-19c	7416-69c	7473-39c	7492-75c	74157-75c
74LS02-49c	7420-19c	7474-35c	7493-69c	74161-95c
7404-19c	7430-19c	74LS74-59c	7495-75c	74164-1.10
74LS04-29c	7432-34c	7475-69c	7496-89c	74165-1.10
74S04-44c	7437-39c	7476-35c	74121-38c	74174-95c
74LS04-49c	7438-39c	7480-49c	74123-65c	74181-2.50
7406-29c	7440-19c	7483-95c	74132-1.70	74191-1.25
7408-19c	7447-85c	7485-95c	74S138-1.95	74192-1.25
7410-19c	7448-85c	7486-45c	74141-75c	74193-1.00
TTL INTEGRATED CIRCUITS				74195-69c

STICK IT!
in your clock
in your DVM, etc.!

Huge Special Purchase
Not Factory Seconds
As sold by others!

\$3.95

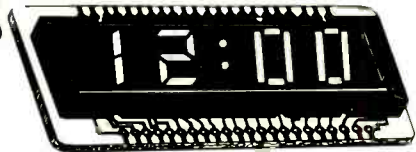

4 JUMBO .50"
DIGITS ON
ONE STICK!
(with colons and
AM/PM Indicator)

BUY 3 for \$10.

BOWMAR 4 DIGIT LED READOUT ARRAY

The Bowmar Opto-Stick. The best readout bargain we have ever offered. Has four common cathode jumbo digits with all segments and cathodes brought out. Increased versatility since any of the digits may be used independently to fit your applications. Perfect for any clock chip, especially direct drive units like 50380 or 7010. Also use in freq. counters, DVM's, etc. For 12 or 24 hour format.

UP YOUR COMPUTER!

21L02-1 1K LOW POWER 500 NS STATIC RAM TIME IS OF THE ESSENCE!

And so is power. Not only are our RAM'S faster than a speeding bullet but they are now very low power. We are pleased to offer prime new 21L02-1 low power and super fast RAM's. Allows you to STRETCH your power supply farther and at the same time keep the wait light off. **8 for \$12.95**

\$12.95 S.D. SALES EXCLUSIVE! **\$12.95**
MOS 6 DIGIT UP-DOWN COUNTER

40 PIN DIP. Everything you ever wanted in a counter chip. Features: Direct LED segment drive, single power supply (12 VDC TYP.), six decades up/down, pre-loadable counter, separate pre-loadable compare register with compare output, BCD AND seven segment outputs, internal scan oscillator, CMOS compatible, leading zero blanking, 1MHz. count input frequency. Very limited qty. **WITH DATA SHEET**

WESTERN DIGITAL UART

No. TR1602B. 40 pin DIP
This is a very powerful and popular part.
**NEW-\$6.95 with data
LIMITED QUANTITY**

**RESISTOR
ASSORTMENT**
1/4 W 5% and 10%
PC leads. A good mix
of values. 200/\$2.

FAIRCHILD BIG LED READOUTS

A big .50 inch easy to read character. Now available in either common anode or common cathode. Take your pick. Super low current drain, only 5MA per segment typical.

FND 510 Common Anode
FND 503 Common Cathode
PRICE SLASHED! 59c each

TERMS:
Money Back Guarantee. No COD. Texas Residents add 5% tax. Add 5% of order for postage and handling. Orders under \$10. add 75c. Foreign orders: US Funds ONLY!

SLIDE SWITCH ASSORTMENT

Our best seller. Includes miniature and standard sizes, single and multi-position units. All new, first quality, name brand. Try one package and you'll reorder more. **SPECIAL 12/\$1.**

MOTOROLA POWER DARLINGTON Back in Stock!

Like MJ3001. NPN 80V. 10A HFE 6000 TYP. TO-3 case. We include a free 723C volt reg. with schematic for power supply. **SPECIAL-\$1.99**

**CALL YOUR BANK
AMERICARD OR MASTER
CHARGE ORDER IN ON
OUR CONTINENTAL
UNITED STATES TOLL
FREE WATTS:**

1-800-527-3460

Texas Residents Call Collect
214/271-0022

**S.D. SALES CO.
P.O. BOX 28810 - C
Dallas, Texas 75228**

For orders over \$15.00 Choose \$1.00 FREE mdse.

CIRCLE 55 ON FREE INFORMATION CARD

10% OFF WITH \$25 ORDER
15% OFF WITH \$100 ORDER
 THESE DISCOUNTS APPLY TO TOTAL
 OF ORDER — SPECIALS INCLUDED

TTL					
7400	.13	7451	.17	74153	.89
7401	.16	7453	.17	74154	1.20
7402	.15	7454	.17	74155	.97
7403	.15	7460		74156	.97
7404	.16	7464	.35	74157	.99
7405	.19	7465	.35	74158	1.79
7406	.20	7470	.30	74160	1.23
7407	.28	7472	.30	74161	.97
7408	.18	7473	.35	74162	1.39
7409	.19	7474	.28	74163	1.09
7410	.16	7475	.49	74164	.99
7411	.25	7476	.30	74165	.99
7413	.43	7483	.68	74166	1.25
7414	.65	7485	.88	74170	2.10
7416	.35	7486	.40	74173	1.49
7417	.35	7489	2.23	74174	1.23
7420	.16	7490	.45	74175	.97
7422	.30	7491	.75	74176	.89
7423	.29	7492	.48	74177	.84
7425	.27	7493	.48	74180	.90
7426	.26	7494	.78	74181	2.45
7427	.29	7495	.79	74182	.79
7430	.20	7496	.79	74184	1.90
7432	.23	74100	.98	74185	2.20
7437	.25	74105	.44	74187	5.75
7438	.25	74107	.37	74190	1.15
7440	.15	74121	.38	74191	1.25
7441	.89	74122	.38	74192	.95
7442	.59	74123	.65	74193	.85
7443	.73	74125	.54	74194	1.25
7444	.73	74126	.58	74195	.74
7445	.73	74132	.89	74196	1.25
7446	.81	74141	1.04	74197	.73
7447	.79	74145	1.04	74198	1.73
7448	.79	74150	.97	74199	1.69
7450	.17	74151	.79	74200	5.45

LOW POWER					
74100	.29	74151	.29	74190	1.40
74102	.29	74155	.29	74191	1.20
74103	.23	74171	.29	74193	1.50
74104	.29	74172	.45	74195	1.50
74106	.29	74173	.56	74198	2.25
74110	.29	74174	.56	74164	2.25
74120	.29	74178	.75	74165	2.30
74130	.29	74185	1.09		
74142	1.39	74186	.65		

LOW POWER SCHOTTKY					
74150	.36	741532	.38	741595	2.09
741502	.36	741540	.45	7415107	.59
741504	.36	741542	1.40	7415164	2.20
741508	.38	741574	.59	7415193	2.20
741510	.36	741590	1.30	7415197	2.20
741520	.36	741593	1.30		

HIGH SPEED					
74H00	.25	74H22	.25	74H61	.25
74H01	.25	74H30	.25	74H62	.25
74H04	.25	74H40	.25	74H74	.39
74H08	.25	74H50	.25	74H101	.58
74H10	.25	74H52	.25	74H102	.58
74H11	.25	74H53	.25	74H103	.60
74H20	.25	74H55	.25	74H106	.72
74H21	.25	74H60	.25	74H108	.72

SCHOTTKY					
74500	.38	74508	.52	74522	.38
74502	.45	74510	.38	74532	.52
74503	.38	74520	.38	74574	.38
74504	.45				

8000 (NATIONAL)					
8091	.61	8220	1.44	8811	.65
8092	.61	8220	2.14	8812	1.02
8095	1.25	8288	1.49	8822	2.19
8121	1.40	8520	1.16	8830	2.14
8123	1.83	8552	2.19	8831	2.19
8200	2.31	8561	.62	8836	.29
8214	1.49	8810	.70	8880	1.19

8000 (SIGNETICS)					
8263	5.79	8267	2.59		

8000					
9002	.40	9309	.74	9601	.61
9301	1.03	9312	.79	9602	.79

DVM CHIP 4 1/2 DIGIT
 MM5330 — P channel device provides all logic for 4 1/2 digit volt meter. 16 pin DIP with data **\$9.95**



IC BREADBOARD
 Accommodates 5 16 pin IC's with additional interconnection holes. 1/16" phenolic with silver plated copper circuits. 2 5/16" x 6 9/16" **\$1.80 ea.**

UNIVERSAL BREADBOARD
 Silver plated copper circuit board. 1 1/2" x 3 1/2" x 1 1/2". 2 rows of 20 holes for DIP IC's. Space for transistors, resistors & capacitors. Versatile and simple for breadboarding IC circuits **\$1.50 ea.**

SHIFT REGISTERS					
MM5013	1024 bit accum. dyn.	1.75			
MM5016	500/512 bit dyn.	1.59			
515-4025	Quad 25 bit	.99			
2504	1024 bit multiplexed dyn	3.95			

IC SOCKETS					
Solder Tail - low profile					
8 pin	\$.17	24 pin	.42		
14 pin	.50	28 pin	.59		
16 pin	.22	40 pin	.69		
18 pin	.29				

WIRE WRAP - gold plate
 14 pin .49

CMOS					
4000A	.26	4018A	1.39	4066A	.89
4001A	.25	4020A	1.72	4068A	.44
4002A	.25	4021A	1.18	4069A	.44
4006A	1.35	4022A	.94	4071A	.26
4007A	.26	4023A	.25	4072A	.35
4008A	1.52	4024A	.89	4073A	.39
4009A	.57	4025A	.25	4075A	.39
4010A	.54	4027A	.59	4078A	.39
4011A	.29	4028A	.98	4082A	.35
4012A	.25	4030A	.44	4518A	1.56
4013A	.45	4035A	1.27	4528A	1.56
4014A	1.27	4040A	1.39	4585A	2.10
4015A	1.27	4042A	1.47		
4016A	.48	4049A	.59		
4017A	1.01	4050A	.59		

74C00	.19	74C74	1.34	74C162	2.49
74C02	.26	74C76	1.04	74C163	2.66
74C04	.44	74C107	1.13	74C164	2.66
74C08	.68	74C151	2.62	74C173	2.22
74C10	.35	74C154	3.15	74C195	2.26
74C20	.35	74C157	1.76	80C95	1.15
74C42	1.61	74C160	2.48	80C97	.96
74C73	1.04	74C161	2.49		

TANTALUM CAPACITORS					
Solid dipped +20%					
1 mld	35V	.25	10 mld	16V	\$.40
.33 mld	35V	.25	10 mld	25V	.45
1 mld	35V	.25	15 mld	10V	.40
2.2 mld	20V	.25	15 mld	20V	.45
2.2 mld	35V	.30	22 mld	16V	.45
3.3 mld	35V	.30	33 mld	10V	.40
4.7 mld	16V	.30	47 mld	6V	.40
6.8 mld	6V	.30	56 mld	6V	.45
6.8 mld	50V	.40	150 mld	15V	.50

MEMORIES					
1101	256 bit RAM MOS 16 pin	1.39			
1103	1024 bit RAM MOS dynamic 18 pin	1.95			
1702A	2048 bit PROM static electrically programmable UV erasable 24 pin	10.95			
2102	1024 bit RAM static 16 pin	1.95			
5203	2048 bit PROM static electrically programmable UV erasable 24 pin	10.95			
5260	1024 bit RAM MOS dynamic 16 pin	1.95			
5261	1024 bit RAM MOS dynamic 16 pin	1.95			
7489	64 bit ROM TTL 16 pin	2.25			
82523	256 PROM-SCHOTTKY 16 pin	3.69			
F93410	256 bit RAM bi-polar 16 pin	1.95			
74187	1024 bit ROM TTL 16 pin	5.75			
74200	256 bit RAM tri-state 16 pin	5.45			

CLOCK CHIPS					
MM5311	6 digit multiplexed BCD, 7 seg. 12-24 Hr. 50-60 Hz	28 pin	4.45		
MM5312	4 digit multiplexed BCD, 7 seg. lpps. 12-24 Hr. 50-60 Hz	— 24 pin	3.95		
MM5314	6 digit multiplexed 12-24 Hr. 50-60 Hz	24 pin	4.45		
MM5316	4 digit, 12-24 Hr. 50-60 Hz, alarm 40 pin		4.95		
5375AA	4-6 digit, 12 hour, 60 Hz snooze alarm brightness control capability, alarm tone output — 24 pin		4.95		
CT7001	6 digit, 12-24 Hr. 50-60 Hz, alarm, timer and date circuits — 28 pin		6.95		

CALCULATOR CHIPS					
CTS002	12 digit, 4 function fixed decimal battery operation — 40 pin		1.95		
CT5005	12 digit, 4 function plus memory, fixed decimal — 20 pin		2.49		
MM5725	8 digit, 4 function, floating decimal 18 pin		1.98		
MM5736	6 digit, 4 function, 9V battery operation — 18 pin		2.95		
MM5738	8 digit, 5 function plus memory and constant floating decimal, 9V battery operation — 24 pin		3.95		
MM5739	9 digit, 4 function, 9V battery operation — 22 pin		3.95		

POCKET CALCULATOR KIT
 5 function plus constant — addressable memory with individual recall — 8 digit display plus overflow — battery saver — uses standard or rechargeable batteries — all necessary parts in ready to assemble form — instructions included
 Calc. Kit, Kit only **\$ 9.95**
 Batteries (alkaline, disp.) **2.00**
 Adapter **3.95**

1702A UV ERASABLE PROM
 — 2048 bit static PROM 256x8
 elect programmable & erasable TTL/DTL comp. **\$6.95**

2102 RAM
 1024 bit built decoded static RAM
 DTL/TTL compatible — 16 pin DIP **\$ 1.49**

ALARM CLOCK CHIP
 MM5375AA 4-6 digit, 12 hour, 60Hz snooze alarm, brightness control capability, alarm tone output 24 pin DIP **\$3.95**

5738 CALCULATOR CHIP
 8 digit multiplexed live function — chain operation 2 key memory — floating decimal — independent constant — interfaces with led with only digit driver — 9 V batt. oper. 24 pin **2.95**

7001 CLOCK CHIP
 4-6 digit, 12-24 hr. alarm, timer and date circuits — with data **\$5.95**

DVM CHIP 4 1/2 DIGIT
 MM5330 — P channel device provides all logic for 4 1/2 digit volt meter. 16 pin DIP with data **\$6.95**

SPECIAL DEVICES					
372	AF-IF Strip Detector DIP	2.93			
546	AM Radio Receiver Subsystem DIP	.75			
1310	FM Stereo Demodulator DIP	2.90			
1496	Balanced Modulator-Demodulator	.99			
1800	Stereo Multiplexer DIP	2.48			
ULN2208	FM Gain Block 34db (typ) mDIP	1.18			
ULN2209	FM Gain Block 48db (typ) mDIP	1.35			
2513	Character Generator 64x8x5 DIP-24	10.20			
3046	Transistor Array DIP-14	.73			

6 Digit Clock Kit
 MM5314 with 6 NS71 .27" displays 2 P.C. boards — Display board may be remote. Internal or wall transformer can be used. 50-60 Hz, 12-24 hour. Includes all necessary transistors, resistors, capacitors, diodes, 3 switches and complete assembly instructions. **\$14.95**

4 Digit Clock Kit
 MM5312 and 4 NS71 .27" displays 12-24 hours, 50-60 Hz. On-board accommodates clock, displays, and all necessary transistors, resistors, capacitors, diodes, 2 switches, complete instructions and schematics for assembly. **\$10.95**

Mark I
 A six digit clock kit with one double sided P.C. board accommodates MM5314 clock chip and 6 FND359 .375" displays. 12-24 hour, 50-60 Hz. Contains all necessary components, 3 switches and complete assembly instructions with schematics. Connections for remote displays. **\$13.95**

DISPLAYS					
MAN1	\$1.95				
MAN2	3.95				
MAN3A	.19				
MAN5	2.25				
MAN6	2.49				
MAN7	1.49				
MAN8	2.25				
MAN66	2.25				
DL10A	2.19				
FND500	1.89				
NS71L	1.39				

DISCRETE LED'S					
ME4	\$.24				
MV50	.12				
NS100	.12				
NS101	.12				
NS102	.15				
MV5020					
RED	.15				
GREEN	.15				
AMBER	.15				
CLEAR	.15				

MULTIPLE DISPLAYS					
NSN31	3 digit .12" red LED	1.79			
HP5082	5 digit .11 red LED	3.49			
7405					
HP5082	4 digit .11 red LED	3.25			
7414					
SP-425-09	9 digit .25 gas disch.	1.79			

--

Z-80

INTRODUCTORY SPECIALS

RM Z-80 CPU System, w/1K RAM, Monitor ROM, serial--parallel I/O ports, provision for additional I/O ports, PROMS on main board, compatible with existing 8080 software. Complete Kit **\$259.95**

RM-4K Static RAM Board 300ns, for above system, low power 2102's, IC sockets, kit **\$139.95**
Keyboards, Power Supply kits available.

RM Z-80 System, complete kit with enclosure, shown below, 5K of 300 ns memory, Monitor ROM, keyboard, power supply, ONLY \$529.95
w/VIDEO Display Board, add **\$99.95**
w/Teletype 33 Printer, used, add **\$445.**
RM case, below, holds all of above, including up to 64K of memory.



16K Static RAM Board, 215 ns access time, extreme low power, kit, RM or Altair/IMSAI version **\$479.95**

Altair/IMSAI 4K Static Memory Board w/2102 RAM's **ONLY \$79.95**
High-speed low-power versions available.

MONITOR 80A Super System Monitor in ROMS for 8080's and Z-80's, replaces over 2K of system memory, supports entry and dump in symbolic, many other routines. Turn your system on and start programming. \$74.95 value, NOW **ONLY \$59.95**

With PROM-ROM Board for Altair/IMSAI, will hold additional 8 PROMS 1K x 8 2708 type **Special \$109.95**
ASSEMBLED and TESTED Boards and Systems available.

8080 and 6800 Systems available at extremely low prices.

Send stamped, self-addressed envelope or contact your favorite dealer.

MiniMicroMart

1618 James Street
Syracuse, New York 13203
(315) 422-4467

CIRCLE 21 ON FREE INFORMATION CARD

H.H. SCOTT Misc Etched & Drilled P.C. Boards Asst.....15—\$1.00

SILICON SOLAR CELLS. 4X.8 in. \$1.00
8X.8 in. \$1.50

GOULD NICADS NEW
"AA Cells10—\$10.00
Sub "C" Cells10—\$12.00

GREEN LED4—\$1.00
YELLOW LED
w/MOUNT COLLAR.....3—\$1.00

GALLIUM ARSENIDE
IRLED EMITTER.....\$1 or 6/\$5.00

40 PIN SOCKET FOR MM5314- 5316- UART—Etc.\$1.00 6/\$5.00

MAGNETIC RECORDING TAPE 1/4"
Audio 3600 Ft..... \$1.50
10 for \$12.00
1800 Ft. \$1.15
10 for \$10.00

Meshna **SURPLUS ELECTRONIC MATERIAL**
P.O. Box 62
19 ALLERTON STREET
E. LYNN MASS. 01904

CIRCLE 51 ON FREE INFORMATION CARD

PARTS

NEW AND SURPLUS PARTS
IC'S-RES-CAPS-SWITCHES
P C BOARDS & CHEMICALS
COMPUTER PARTS
T V GAMES
CALC & LCD WATCH PARTS

KITS

MUSIC SYNTHESIZER KITS
PHASE SHIFTERS
AUDIO KITS AND PARTS
POWER SUPPLIES & KITS
CALCULATOR KITS
ORGAN/SYNTH KEYBOARDS

SERVICES

CIR. BOARD FABRICATION
C. BOARD COOKBOOK-6.50
METAL FAB. & SUPPLIES
CUSTOM AUDIO DESIGN

SEND 13¢ STAMP FOR
1977 CATALOG

UTEP

DEP.3-BOX 26231
S.L.C., UT. 84125

CIRCLE 70 ON FREE INFORMATION CARD

ALL AN ASR 33 IS AND MORE!
OLIVETTI 318 TELETYPEWRITER
BUILT-IN PAPER TAPE I/O
KEYBOARD PLUS 10 KEY PAD
HEAVY DUTY BUT QUIET
NATIONAL SERVICE **\$950**
+ SHIPPING

A REAL COMPUTER VIDEO - IDEAL FOR
ALPHANUMERIC WORK
1 VOLT P TO P INPUT
ANTI GLARE SCREEN
GREEN PHOSPHOR
12" DIAGONAL SCREEN
\$150 +\$10 SHIPPING

KITS: ADM-3 IMSAI 8080 SWTPC TERMINAL SWTPC 6800 KIM 1 OS1

WRITE FOR OUR CATALOG **COMPUTER WAREHOUSE STORE**
DEPT. R
PO BOX 68, KENMORE STATION
BOSTON, MASS 02215
617-261-2701

NEW adjustable three-output regulated power supply, plus 900 parts worth \$400.00 list, contained in a solid-state Cartrivision television recorder electronic unit. Schematics, parts cross-reference furnished. Uses Heathkit television transistor substitutions, power CB radios and microprocessors, build electronic projects. \$17.95 plus \$3.50 S&H, USA. Free brochure. Master Charge, BankAmericard. Satisfaction guaranteed. MADISON ELECTRONICS COMPANY, INCORPORATED, Box 369, D101, Madison, AL 35758

PROFESSIONAL unscramblers—use with any scanner. Free information. CAPRI ELECTRONICS, 8753R Windom, St. Louis, MO 63114

PRINTED CIRCUIT

Positive Acting Photo Resist; Carbide/bits; Bubble etchers; Artwork; Epoxy Glass Boards.

Send stamp & address label for flyer
TRUMBULL

833 Balra Dr., El Cerrito, CA 94530

CB theft alarm. Protects CB's, radios, tape decks, etc. Horn blows when CB is removed. \$4.95 complete prepaid. DELTA, Box 107, Tyngsboro, MA 01879

NAME brand digital analog test equipment. Discount prices. Free catalog. SALEN ELECTRONICS, Box 82, Skokie, IL 60076

AMAZING ELECTRONIC PROJECTS and PRODUCTS:

Lasers Super Powered, Burning, Cutting, Rifle, Pistol, Pocket. See in Dark—Shotgun Directional Mike—Unscramblers—Giant Tesla—Stunwand—TV Disrupter—Energy Producing, Surveillance, Detection, Electrifying, Ultrasonic, CB, Auto and Mech. Devices, Hundreds More—All New Plus INFO UNLTD PARTS SERVICE. Catalog \$1. Information Unlimited, Box 626, Lord Jeffery Court, Amherst, N.H. 03031.

ELECTRONIC parts! New! Solid-state devices! Free flyer. DARTEK ELECTRONICS, Box 2460, Dartmouth, Nova Scotia, Canada. U.S. inquiries invited.

TRANSISTORS, LED's, IC's, solar cells, resistors, capacitors, loads of goodies. Catalog 25¢ refundable. DIAMONDBACK ELECTRONICS, Box 194R, Spring Valley, IL 61362.

Thanks to you
it works...
FOR ALL OF US



United Way

advertising contributed for the public good.



TTL 7400N

SN7400N	15	SN74121N	36
SN7401N	15	SN74122N	42
SN7402N	15	SN74123N	59
SN7403N	15	SN74125N	45
SN7404N	18	SN74126N	45
SN7405N	18	SN74128N	65
SN7406N	18	SN74132N	84
SN7407N	34	SN74136N	64
SN7408N	18	SN74141N	93
SN7409N	18	SN74142N	370
SN7410N	15	SN74143N	398
SN7411N	21	SN74144N	398
SN7412N	28	SN74145N	89
SN7413N	41	SN74147N	168
SN7414N	79	SN74148N	125
SN7416N	26	SN74150N	99
SN7417N	31	SN74151N	63
SN7420N	15	SN74153N	63
SN7421N	21	SN74154N	99
SN7422N	21	SN74155N	99
SN7423N	27	SN74156N	69
SN7425N	27	SN74159N	250
SN7426N	24	SN74160N	89
SN7427N	27	SN74161N	89
SN7428N	35	SN74162N	89
SN7430N	15	SN74163N	89
SN7432N	24	SN74164N	110
SN7433N	35	SN74165N	99
SN7437N	23	SN74166N	119
SN7438N	23	SN74167N	298
SN7440N	15	SN74170N	175
SN7442N	38	SN74172N	89
SN7443N	21	SN74173N	89
SN7444N	85	SN74174N	99
SN7445N	74	SN74175N	89
SN7446AN	78	SN74176N	79
SN7447AN	78	SN74177N	78
SN7448N	74	SN74178N	125
SN7450N	15	SN74179N	160
SN7451N	15	SN74180N	69
SN7453N	15	SN74181N	199
SN7454N	15	SN74182N	69
SN7460N	15	SN74184N	189
SN7470N	28	SN74185AN	185
SN7472N	27	SN74186N	69
SN7473N	31	SN74188N	350
SN7474N	31	SN74190N	109
SN7475N	48	SN74191N	109
SN7476N	34	SN74192N	88
SN7480N	39	SN74193N	88
SN7481AN	99	SN74194N	94
SN7482N	59	SN74195N	59
SN7483AN	69	SN74196N	93
SN7484AN	165	SN74197N	83
SN7485N	88	SN74198N	169
SN7486N	32	SN74199N	169
SN7489N	195	SN74201N	120
SN7490AN	45	SN74246N	195
SN7491AN	64	SN74247N	185
SN7492AN	46	SN74248N	175
SN7493AN	46	SN74249N	175
SN7494N	74	SN74251N	140
SN7495AN	69	SN74265N	85
SN7496N	69	SN74278N	245
SN7497N	285	SN74279N	59
SN74100N	99	SN74283N	145
SN74104N	43	SN74284N	450
SN74105N	43	SN74285N	450
SN74107N	29	SN74290N	85
SN74109N	49	SN74293N	85
SN74110N	54	SN74298N	198
SN74111N	74	SN74351N	192
SN74116N	175	SN74365N	65
SN74120N	140	SN74366N	65
		SN74367N	65
		SN74368N	65
		SN74393N	140
		SN74490N	190

ZENER DIODES

IN4728-IN4752A	19
(1 watt molded)	
IN746A-IN759A	15
(400 MW)	

TTL LOW POWER SCHOTTKY

SN74LS00N	25	SN74LS138N	149
SN74LS01N	25	SN74LS139N	149
SN74LS02N	25	SN74LS145N	125
SN74LS03N	25	SN74LS151N	125
SN74LS04N	30	SN74LS153N	125
SN74LS05N	30	SN74LS155N	145
SN74LS08N	25	SN74LS156N	145
SN74LS09N	25	SN74LS157N	125
SN74LS10N	25	SN74LS158N	120
SN74LS11N	25	SN74LS160N	195
SN74LS12N	25	SN74LS161N	195
SN74LS13N	69	SN74LS162N	195
SN74LS14N	135	SN74LS163N	195
SN74LS15N	25	SN74LS164N	198
SN74LS20N	25	SN74LS168N	225
SN74LS21N	25	SN74LS169N	225
SN74LS22N	25	SN74LS170N	280
SN74LS26N	40	SN74LS174N	140
SN74LS27N	30	SN74LS175N	140
SN74LS28N	30	SN74LS181N	350
SN74LS30N	25	SN74LS190N	195
SN74LS32N	37	SN74LS191N	195
SN74LS33N	39	SN74LS192N	195
SN74LS37N	39	SN74LS193N	195
SN74LS38N	39	SN74LS194A	140
SN74LS40N	30	SN74LS195A	140
SN74LS42N	110	SN74LS196N	145
SN74LS48N	110	SN74LS197N	145
SN74LS47N	110	SN74LS221N	135
SN74LS48N	110	SN74LS240N	250
SN74LS49N	110	SN74LS241N	250
SN74LS51N	25	SN74LS242N	250
SN74LS54N	25	SN74LS243N	240
SN74LS55N	25	SN74LS244N	250
SN74LS63N	175	SN74LS247N	130
SN74LS73N	49	SN74LS248N	130
SN74LS74N	49	SN74LS249N	130
SN74LS75N	69	SN74LS251N	155
SN74LS76N	49	SN74LS253N	155
SN74LS78N	49	SN74LS257N	160
SN74LS83AN	149	SN74LS258N	150
SN74LS85N	175	SN74LS261N	295
SN74LS86N	58	SN74LS266N	59
SN74LS90N	99	SN74LS279N	75
SN74LS91N	115	SN74LS283N	140
SN74LS92N	110	SN74LS290N	135
SN74LS93BN	99	SN74LS293N	135
SN74LS95AN	160	SN74LS295AN	175
SN74LS96N	175	SN74LS298AN	175
SN74LS107N	49	SN74LS324AN	225
SN74LS109N	55	SN74LS352AN	145
SN74LS112N	49	SN74LS353AN	140
SN74LS113N	49	SN74LS365AN	75
SN74LS114N	49	SN74LS366AN	75
SN74LS122N	89	SN74LS367AN	75
SN74LS123N	109	SN74LS368AN	75
SN74LS124N	195	SN74LS375AN	80
SN74LS125N	75	SN74LS386AN	59
SN74LS126N	75	SN74LS395AN	195
SN74LS132N	125	SN74LS670AN	295
SN74LS136N	55		

We offer the largest variety of current production Texas Instruments and Fairchild Semiconductor only 74LS devices from stock. Even through the competition for current production major manufactured 74LS devices is limited, we are dedicated to provide the best prices possible. As our costs decrease, we pass the savings on to you, our customer.

CMOS

CD4000BE	10
CD4001BE	19
CD4002BE	14
CD4006BE	1.19
CD4007BE	18
CD4008BE	85
CD4009BE	39
CD4010BE	39
CD4011BE	19
CD4012BE	18
CD4013BE	39
CD4014BE	95
CD4015BE	95
CD4016BE	39
CD4017BE	99
CD4018BE	1.09
CD4019BE	44
CD4020BE	1.09
CD4021BE	1.15
CD4022BE	95
CD4023BE	19
CD4024BE	69
CD4025BE	18
CD4026BE	1.45
CD4027BE	44
CD4028BE	79
CD4029BE	89
CD4030BE	39
CD4033BE	1.70
CD4034BE	2.95
CD4035BE	1.05
CD4040BE	1.05
CD4041BE	69
CD4042BE	65
CD4043BE	50
CD4044BE	50
CD4049BE	39
CD4050BE	39
CD4051BE	1.20
CD4052BE	1.20
CD4053BE	1.25
CD4055BE	1.35
CD4056BE	1.50
CD4060BE	1.50
CD4066BE	65
CD4068BE	25
CD4069BE	25
CD4070BE	25
CD4071BE	25
CD4072BE	30
CD4073BE	30
CD4074BE	30
CD4076BE	1.10
CD4078BE	25
CD4081BE	25
CD4082BE	30
CD4085BE	75
CD4086BE	75
CD4087BE	1.20
CD4507BE	54
CD4510BE	1.10
CD4511BE	1.50
CD4512BE	1.20
CD4516BE	1.19
CD4518BE	95
CD4519BE	89
CD4520BE	89
CD4528BE	1.25
CD4531BE	1.25
CD4539BE	1.20
CD4555BE	75
CD4556BE	75
CD4585BE	1.80
74C85/40085PC	1.20
74C160/40160PC	1.65
74C161/40161PC	1.65
74C162/40162PC	1.65
74C163/40163PC	1.65
74C174/40174PC	1.50
74C175/40175PC	1.50
74C192/40192PC	1.65
74C193/40193PC	1.65
74C194/40194PC	1.50
74C195/40195PC	1.50

LED's

Litronix	1.05
IL1	1.15
IL5	1.05
IL12	69
IL74	82
AL2	23
Texas Instruments	
TIL111	99
TIL112	95
TIL113	1.25
TIL114	1.15
TIL116	1.20
TIL117	1.30
TIL118	80
TIL119	85
TIL138	2.25
TIL139	2.25
TIL209A	18
TIL211	39
TIL220	20
TIL221	19
TIL222	35
TIL23	1.98
TIL24	3.98
TIL302	3.98
TIL303	3.98
TIL304	3.98
TIL305	4.95
TIL307	7.95
TIL308	7.95
TIL309	7.95
TIL311	8.95
TIL312	1.60
TIL313	1.60
TIL31	1.50
TIL32	85
TIL63	95
TIL66	75
TIL78	60
TIL81	1.20
LS600	2.10
Fairchild	
FCD802	60
FCD806	60
FCD810	75
FCD820A	75
FLV117	18
MV5054-1	1.75
FND357	1.75
FND500	1.75
FND507	1.75
FND807	3.00
FNS700	60

Plastic Power Transistors

TIP29A	45	TIP116	81
TIP30C	59	TIP117	93
TIP31A	52	TIP121	123
TIP32A	55	TIP122	153
TIP33C	90	TIP125	133
TIP41A	65	TIP127	163
TIP42A	75	TIP295	89
TIP47	88	TIP305S	85
TIP117	80		

LINEARS

LM301AH	(mini dip)	34
LM301AN-8		74
LM304H		35
LM305AH		78
LM307H		90
LM307N-8	(mini dip)	28
LM308H		84
LM309H		75
LM309K		115
LM311H		89
LM311N-8	(mini dip)	99
LM318H		50
LM318N-8	(mini dip)	25
LM323K		95
LM324N		10
LM339N		20
LM555N-8	(mini dip)	44
LM556N-4		89
LM709CN-4		24
LM710CN-4		29
LM711CH		50
LM723CH		49
LM723CN-4		99
LM733CN-4		49
LM739CN-4		20
LM740CH		30
LM741CH		50
LM741CN	(mini dip)	28
LM741CN-8		25
LM747CN-4		64
LM748CN-4	(mini dip)	29
LM748CH		45
LM776CH		150
LM776CN-4	(mini dip)	150
LM1437N-4		49
LM1458H		54
LM1458N-8	(mini dip)	69
LM1488D		1.75
LM3045N-4		85
LM3302N-4		95
LM4136N-4		1.50

LINEAR VOLTAGE REGULATORS

LM7800 Series	1.90	Positive Voltage Regulators 1 amp
T0-3		5, 6, 8, 12, 15, 18, 24 Volts
LM7800 Series	1.80	Positive Voltage Regulators
T0-5		5, 6, 8, 12, 15, 18, 24 Volts
LM7800 Series	1.60	Positive Voltage Regulators 1 amp
(Plastic) T0-220		5, 6, 8, 12, 15, 18, 24 Volts
LM7800M Series	1.47	Positive Voltage Regulators
T0-220		1/2 Amp 5, 6, 8, 12, 15, 20, 24 Volts
LM78L00 AWC	4.5	Positive Voltage Regulators 70 MA
Series T0-92		2, 5, 6, 12, 15, 26, 62, 82 Volts
LM7900 Series	2.50	Negative Voltage Regulators, 1 amp
T0-3		5, 6, 8, 12, 15, 18, 24 Volts
LM7900 Series	1.87	Negative Voltage Regulators, 1 amp
T0-220		5, 6, 8, 12, 15, 18, 24 Volts
LM79M00 Series	1.80	Negative Voltage Regulators, 1/2 amp
T0-5		5, 6, 8, 12, 15, 18, 24 Volts
LM79M00 Series	1.60	Negative Voltage Regulators, 1/2 amp
T0-220		5, 6, 8, 12, 15, 18, 24 Volts
78MGT2		

BIG-BRIGHT - .5" LED ALARM CLOCK 6 DIGIT AC or DC or ELAPSED TIMER KIT

\$19.95 Complete

- PC Board Drilled & Silk Screened (Includes Xtal Time Base Circuitry)
- 5375 Nat. Clock Chip & Fairchild Displays
- Includes EVERY part required for clock and all options except Cabinet and Crystal Time Base components. If desired, see below.
- Brightness Control
- Freeze feat. on every mode
- Field Tested over 1 Yr.
- 24 Hr. Alarm w/snooze
- 0-60 Min. Elapsed Timer
- 12 Hr., 60 Hz oper.

Most Important — Complete Instructions, schematics Pictorials, layouts — everything for trouble free assembly

OPTION — XTAL Time Base Components - \$2.95 when purchased w/clock
Wooden Case - Walnut gr. incl. Filter \$4.00 each
 Dimension - 6 5/16" W x 2 9/16" H x 3 7/16" D (% Material)

Plexiglass Case (Ch. - Bl., White, Blue, & Smoke) incl. Filter \$3.00 each
 Dimensions - 5 13/16" W x 2 1/4" H x 5 3/8" D (% Material)

Individual Filters - Red, Smoke, Blue, Amber and Green \$.60 each

SPECIALS

8080A Microprocessor	\$19.95 ea.
21L02-1 Low Power 500NS RAM	\$1.95 ea.
6" Display Common Anode or Cathode	\$1.95 ea.
5" Fairchild Display Com. Anode or Cathode	79¢ ea.
(Same as FTK 0001 & FTK 0002)	
8" 3 1/2 Digit Display Module	\$5.40
(Same as FTK 0010)	
LM309K - 5 Volt Regulator - Raytheon	79¢
LM340T Series Regs. - 5, 6, 12, 15 & 24 V (pos)	99¢
LM741 Op. Amp. 14 Pin Dip Pkg	4 for 99¢
2N3055 NPN Transistor T0-3 Pkg	59¢
2N4904 PNP (complement to 2N3055)	69¢
25 Amp - 200 Volt Full Wave Bridge	\$1.49

HOBB-Y-TRONIX, INC.

Box 511, Edison, N.J. 08817

Orders must include Check - No COD's. Add \$1.00 handling for orders under \$25.00. N.J. residents - add 5% tax.

CIRCLE 63 ON FREE INFORMATION CARD

CB SPECIALS - R.F. DRIVERS - R.F. POWER OUTPUTS - FETS

2SC481 1.85	2SC767 15.75	2SC866 5.85	2SC1449-1 1.60	40081 1.50
2SC482 1.75	2SC773 .85	2SC1013 1.50	2SC1475 1.50	40082 3.00
2SC495 1.10	2SC774 1.75	2SC1014 1.50	2SC1678 5.50	2SC608 4.85
2SC502 3.75	2SC775 2.75	2SC1017 1.50	2SC1679 4.75	SK3046 2.15
2SC517 4.75	2SC776 3.00	2SC1018 1.50	2SC1728 2.15	SK3047 3.75
2SC614 3.80	2SC777 4.75	2SC1173 1.25	2SC1760 2.15	SJ2095 3.50
2SC615 3.90	2SC778 3.25	2SC1226A 1.25	2SC1816 5.50	SK3048 3.25
2SC616 4.15	2SC797 2.50	2SC1237 4.50	2SC1908 .70	SK3054 1.25
2SC617 4.25	2SC798 3.10	2SC1243 3.50	2SC1957 1.50	
2SC699 4.75	2SC871 3.00	2SC1249 1.50	2SF8 3.00	2SK19 1.75
2SC710 .70	2SC789 1.00	2SC1306 4.75	HEP-S 3001 3.25	2SK30 1.00
2SC711 .70	2SC796 3.15	2SC1306-1 4.90	2SD235 1.00	2SK33 1.20
2SC759 .70	2SC799 4.25	2SC1307 5.75	MRFB004 3.00	
2SC756 3.00	2SC802 3.75	2SC1307-1 6.00	4004 3.00	3SK40 2.75
2SC765 9.50	2SC803 4.00	2SC1377 5.50	4005 3.00	3SK45 2.75
2SC766 10.15	2SC839 .85	2SC1449 1.30	40080 1.25	3SK49 2.75

JAPANESE TRANSISTORS

2SA52 .60	2SB187 .60	2SC458 .70	2SC815 .75	2SC1569 1.25
2SA316 .75	2SB235 1.75	2SC460 .70	2SC828 .75	2SC1756 1.25
2SA473 .75	2SB303 .65	2SC478 .80	2SC829 .75	
2SA483 1.95	2SB324 1.00	2SC491 2.50	2SC830 1.60	2SD30 .95
2SA489 .80	2SB337 2.10	2SC497 1.60	2SC839 .85	2SD45 2.00
2SA490 .70	2SB367 1.60	2SC515 1.80	2SC945 .65	2SD65 .75
2SA505 .70	2SB370 .65	2SC535 .75	2SC1010 .80	2SD68 .90
2SA564 .50	2SB405 .85	2SC536 .65	2SC1012 .80	2SD72 1.00
2SA628 .65	2SB407 1.65	2SC537 .70	2SC1051 2.50	2SD88 1.50
2SA643 .85	2SB415 .85	2SC563 2.50	2SC1061 1.65	2SD151 2.25
2SA647 2.75	2SB461 1.25	2SC605 1.00	2SC1079 3.75	2SD170 2.00
2SA673 .75	2SB463 1.65	2SC620 .80	2SC1096 1.20	2SD180 2.75
2SA679 3.75	2SB471 1.75	2SC627 1.75	2SC1098 1.15	2SD201 1.95
2SA682 .85	2SB474 1.50	2SC642 3.50	2SC1115 2.75	2SD218 4.75
2SA699 1.30	2SB476 1.25	2SC643 3.75	2SC1166 .70	2SD300 2.50
2SA699A 1.75	2SB481 2.10	2SC644 .70	2SC1170 4.00	2SD313 1.10
2SA705 .55	2SB492 1.25	2SC681 2.50	2SC1172B 4.25	2SD315 .75
2SA815 .55	2SB495 .95	2SC684 2.10	2SC1209 .55	2SD318 .95
2SA816 .85	2SB507 .90	2SC686 2.50	2SC1213 .75	2SD341 .95
	2SB511 .70	2SC696 2.35	2SC1226 1.25	2SD350 3.25
2SB22 .65		2SC712 .70	2SC1233 1.50	2SD352 .80
2SB54 .70	2SC206 1.00	2SC717 .70	2SC1233 .85	2SD380 5.70
2SB56 .70	2SC240 1.10	2SC732 .70	2SC1308 4.75	2SD389 .90
2SB77 .70	2SC261 .65	2SC733 .70	2SC1347 .80	2SD-390 .75
2SB128 2.25	2SC291 .65	2SC739 .70	2SC1383 .75	2SD437 5.50
2SB135 .95	2SC320 2.00	2SC715 1.75	2SC1409 1.25	
2SB152 4.50	2SC352 7.50	2SC762 1.90	2SC1410 1.25	MPS-U31 4.00
2SB173 .55	2SC353 .75	2SC783 1.00	2SC1447 1.25	MPS8000 1.25
2SB175 .55	2SC371 .70	2SC784 1.00	2SC1448 1.25	
2SB178 1.00	2SC372 .70	2SC785 1.00	2SC1507 1.25	
2SB186 .60	2SC394 .70	2SC793 2.50	2SC1509 1.25	

POWER-TRANSISTORS HIGH-VOLT. TV. TYPE

BU204 1300V 3.90	BU207 1300V 5.40	2SC1172B 1100V 4.25
BU205 1500V 4.70	BU208 1500V 6.25	2SC1308 1100V 4.95
BU206 1700V 5.90	2SC1170 1100V 4.00	2SC1325 1100V 4.95

CIRCLE 52 ON FREE INFORMATION CARD

For
faster
service

USE
ZIP
CODE

on
all
mail

CLOCKS

6 digit AUTOMOTIVE CLOCK KIT complete with a CRYSTAL TIMEBASE accurate to .01 percent. 12 volts d.c. operation — built in noise suppression and voltage spike protection. Readouts blank when ignition is off — draws 25 mA in standby mode. Has .3 in. readouts. Use it in your car or for all applications where a battery-operated clock is needed. Approximate size 3" x 3.5" x 1.75"

WITH BLACK PLASTIC CASE \$34.95 ppd.
 WITHOUT CASE \$29.95 ppd.
 ASSEMBLED AND TESTED \$45.95 ppd.

MM 5320 TV CAMERA SYNC GENERATOR — this LSI chip supplies the basic sync functions for either color or monochrome 525 line/60 Hz. camera and video applications. The price is \$4.95 ppd. and includes the data sheet.

CMOS CRYSTAL TIMEBASE KITS with .01 percent accuracy. 5-15 v.d.c. operation. Draws only 3 mA at 12 volts. Single I.C. — very small size — the P.C. board is 7/8" x 1-5/8". Choose a main output of 50 or 100 Hz., 60 Hz., 500 or 1000 Hz., or 1 Hz. Several related frequencies are also available on each board, in addition to the main ones listed above. Be sure to specify the Frequency you want. All kits are \$10.95 ppd.

Flyer available — write for it or circle the reader service card.

NEXUS
 TRADING
 CO.
 Box 3357
 San Leandro, Ca 94578

CIRCLE 13 ON FREE INFORMATION CARD

OEM SPECIALS

1N270 .10	2N960 .55	2N2219A .30	2N2913 .75	2N3740 1.00	2N4401 .20
1N914 .10	2N962 .40	2N2221 .25	2N2914 1.20	2N3771 1.75	2N4402 .20
	2N967 .50	2N2221A .30	2N2916A 3.65	2N3772 1.00	2N4403 .70
2N173 1.75	2N1136 1.35	2N2222 .25	2N3019 .50	2N3773 3.00	2N4409 .20
2N178 .90	2N1142 2.25	2N2222A .30	2N3053 .30	2N3819 .32	2N4410 .25
2N2327A 1.15	2N1302 .25	2N2270 .40	2N3054 .70	2N3823 .70	2N4416 .75
2N334 1.20	2N1305 .30	2N2322 1.00	2N3055 .75	2N3866 .20	2N4441 .85
2N336 .90	2N1377 .75	2N2323 1.00	2N3227 1.00	2N3866 .85	2N4442 .90
2N338A 1.05	2N1420 2.00	2N2324 1.35	2N3247 3.40	2N3903 .20	2N4443 1.20
2N398B .90	2N1483 .95	2N2325 2.00	2N3250 .50	2N3904 .20	2N4852 .55
2N404 .30	2N1540 .90	2N2326 2.85	2N3375 6.50	2N3905 .25	2N5061 .30
2N443 1.75	2N1543 2.70	2N2327 3.80	2N3393 .20	2N3906 .25	2N5064 .50
2N456 1.10	2N1549 .80	2N2328 4.20	2N3394 .17	2N3925 3.75	2N5130 .20
2N501A 3.00	2N1549 1.25	2N2329 4.75	2N3414 .17	2N3954 3.50	2N5133 .15
2N508A 4.45	2N1551 2.50	2N2368 .25	2N3415 .18	2N3954A 3.75	2N5138 .15
2N555 .45	2N1552 3.25	2N2369 .25	2N3416 .19	2N3955 2.45	2N5138 3.75
2N652A .85	2N1554 1.25	2N2484 .32	2N3417 .20	2N3957 1.25	2N5198 .50
2N677C 6.00	2N1557 1.15	2N2712 .18	2N3442 1.85	2N3958 1.20	2N5296 .50
2N706 .25	2N1560 2.80	2N2894 .40	2N3553 1.50	2N4037 .60	2N5306 .20
2N706B .40	2N1605 .35	2N2903 3.30	2N3563 .20	2N4093 .85	2N5354 .20
2N711 .50	2N1613 .30	2N2904 .25	2N3565 .20	2N4124 .20	2N5369 .20
2N711B .60	2N1711 .30	2N2904A .30	2N3638 .20	2N4126 .20	2N5400 .40
2N718 .25	2N1907 4.10	2N2905 .25	2N3642 .20	2N4141 .20	2N5401 .50
2N718A .30	2N2060 1.85	2N2905A .30	2N3643 .15	2N4142 .20	2N5457 .35
2N720A .50	2N2102 .40	2N2906 .25	2N3645 .15	2N4143 .20	2N5458 .30
2N918 .35	2N2218 .25	2N2906A .30	2N3646 .14	2N4220A .95	C103Y .25
2N930 .25	2N2218A .30	2N2907 .25	2N3730 1.50	2N4234 .45	C103d .40
2N956 .30	2N2219 .25	2N2907A .30	2N3731 2.75	2N4400 .20	C106b1 .50
					C106d1 .75

SILICON UNIJUNCTIONS

2N2646 .50	2N4871 .50
2N2647 .60	2N4891 .50
2N6027 .55	2N4892 .50
2N6028 .70	2N4893 .50
D5E37 .25	2N4894 .50
2N2160 .65	MU10 .40
2N4870 .50	

INTEGRATED CIRC.

UA703C .40
709C OP. AMP. .25
741C OP. AMP. .25
7400 .15
TA7061P 3.50
TA7205P 8.00
UPC1001h2 6.00
Ne555 1.25

RECTIFIERS

10 100
IN4001 .60 5.00
IN4002 .70 6.00
IN4003 .80 7.00
IN4004 .90 8.00
IN4005 1.00 9.00
IN4006 1.10 10.00
IN4007 1.20 11.00

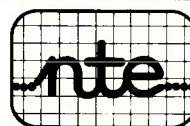

New-Tone Electronics
 P.O. Box 1738 A
 Bloomfield, N.J. 07003
 Phone: (201) 748-6171

ALL PARTS GUARANTEED

N.J. residents add 5% sales tax. Minimum order \$5.00. All orders add \$1.00 postage. Dealers write or phone for discount prices.

748-6172
 748-6173

**AMAZING & HARD-TO-FIND
SCIENCE BUYS!
ALTERNATE ENERGY
SPACE AGE • HOBBIES**

SUPER POWER FOR ANY AM RADIO

Antenna assist has pulled in stations 1000 miles off! No wires, clips, grounding. Solid state—no elec. batts., tubes. No. 72.095EH \$19.95 Ppd. **ULTRA SELECT-A-TENNA (OVER 1000 MILES)** No. 72.147EH.....\$24.95



ELEC. DIG. STOPWATCH: \$39.95

New low price for - 0.002% accuracy! Start, stop, reset compact hand-held 6-ounce w/ one hand, times to 59 min., 59.9 sec. (1/10's), (5-digit dis.)



No. 1671EH.....\$39.95 Ppd.

SPLIT ACTION W/NICADS, RECHARGER

No. 1669EH.....\$79.95 Ppd.

SEE MUSIC IN PULSATING COLOR

3-Channel Color Organ lets you modulate 3 independent strings of colored lamps w/ intensity of your music. "Audio" light show flashes, responds to rhythm, pitch!



No. 42.309EH (ASSEMBLED).....\$18.50 Ppd.

No. 42.336EH (UNASSEMBLED).....\$15.95 Ppd.

NASA-CHOSEN FOR APOLLO/SOYUZ

The Astronauts used this super 20X60 binocular (modified) to view Earth! Big 60 mm objective lenses; 173-ft. field of view at 1000 yds. Relative brightness, 9.0. Fully coated optics, more!



No. 1556EH.....(9 1/4 x 8 1/2"; 47.5 oz) \$99.95 Ppd.

110V FUEL MISER RECLAIMS HEAT

Save your 40% wasted heat to warm a basement, garage, rec. rm. at no extra cost! Direct it your way instead of up the chimney. Fan-forced clean hot air via easy ducting!



No. 19.194EH (5" DIA.) Shpg. 17 lb. ...\$121.50 FOB
No. 19.195EH (6" DIA.);

KNOW YOUR ALPHA FROM THETA!

For greater relaxation & concentration, monitor your Alpha/Theta brainwaves w/aud. or vis. sig. on Biosone II. Feats. of \$200-up units incl. 3 feedback modes! 4-lb.



No. 1668EH (9 1/2 x 5 5/8 x 4 1/4").....\$149.95 Ppd.

No. 71.809EH (FOR BEGINNERS).....\$59.95 Ppd.

ELECTRONIC DIGITAL RAIN GAUGE

... never needs emptying, measures rain up to 100-ft. away by tenths of an inch up to 999.9" and empties itself. Push indoor counter's reset button, start new counting period. Req. 9v batt. (not incl.)



No. 72.165EH \$49.95 Ppd.

DIGITAL WINDSPEED/DIRECTION

Instant, acc. readout: 1-99.9mph wind (nearest 1/10) in red LED; 1 of 24 circular red solid-state lamps shows direction. Indoor console plugs in to 120v AC. No dials, calibrations, calculations!



No. 72.304EH.....\$199.95 Ppd.

CAN'T SLEEP, RELAX? TRY THIS!

Electronic sound conditioner simulates 4 kinds of soothing sounds of ocean surf & rain; "white" sound helps mask unwanted noise. Medical tests proved analgesic effects!



No. 71.997EH \$89.95 Ppd.

QUALITY DETECTOR UNDER \$40

Our fully transistorized BFO unit can locate a quarter at 18". Powerful 6 trans-oscillator-amplifier circuit. Comp. to others priced 50% more! Aluminum, just 2 lb.



No. 80.222EH \$39.95 Ppd.

EDMUND SCIENTIFIC CO.

300 Edscorp Bldg., Barrington, N.J. 08007 • (609) 547-3488
America's Greatest Science • Optics • Hobby Center

**GIANT FREE
164 PG. CATALOG**



**4500 UNUSUAL BARGAINS
FOR HOBBYISTS,
SCHOOLS, INDUSTRY**

**THERE IS NO OTHER TELESCOPE LIKE IT!
THE NEW EDMUND 4 1/4", f/4
NEWTONIAN WIDE FIELD
REFLECTOR TELESCOPE**

Clear, bright, spectacular wide angle views of stars, moon, comets... easy to use... portable!



IN SECONDS YOU'RE SCANNING THE ASTOUNDING UNIVERSE. able to see and study the breath-taking cosmos as perhaps you never have before awesome vastness, unbelievable orderliness, stark silent beauty. All the fascinating heavenly mysteries are yours to enter and explore. This new reflector telescope makes it easy for everyone to span a thousand light-years to space-age enjoyment of the heavens and outdoors. No complicated set up! Just insert the eyepiece, focus, and its big 3 1/2" field of view gives you more stars in a single view than any other type of telescope. Bright, crisp, finely resolved images to capture your interest and imagination. It's probably the easiest to use telescope ever... over your shoulder, in your lap, on a tripod. Or just rotate the spherical base on its own mount for use on a table, car hood. Take it anywhere (only 17" x 10" lb.). Top quality optical system: 4 1/4" f/4 parabolic primary mirror (1/8 wave, 17" F.L.); prealigned 1/8 wave diagonal on a coated optical window seals optics from moisture and dust; 28mm Kellner eyepiece (gives 15X, higher without other eyepiece or Barlow) Fast focusing (25' to infinity). Bright Scharfian red (doesn't impair night vision), ad. carrying strap. A "first" scope "must" ideal second scope!

There is no other telescope like it. NO. 2001EH \$149.95 Ppd.

**FOR GREATER RELAXATION, CONCENTRATION,
listen to your Alpha and Theta brainwaves!**



No. 1689EH

Do it with an amazing biofeedback monitor. This ultra-sensitive sensor detects brain signals, lets you monitor (hear and see!) your Alpha and Theta brainwaves. Great aid to relaxation, concentration. This portable (8 x 3 x 4") lightweight (24 oz.) metal unit has a unique electrode headband to slip on or off in seconds without messy creams or solutions. Hooked to amplifier, it filters brainwaves, and signals an audible beep for each Alpha or Theta wave passed. You get both audio and visual (L.E.D.) feedback with this reliable, completely safe unit. It operates on two 9v transistor batteries, offers features comparable to many costlier models. A comprehensive instruction booklet is included.

Do-It-Yourself Kit #61069EH.....\$37.50 ppd.
Low Cost 'Starter' Unit #71809EH.....\$59.95 ppd.

No. 1689EH JUST \$99 Ppd.

**LOW COST, HIGH QUALITY
INFRA - RED EYE**

Binocular Style, \$329.95; Standard, Only \$299.95



A must for Infra-red crime detection surveillance, security system alignment, I.R. detection, laser checking, night-time wildlife study—any work requiring I.R. detection and conversion to the visible spectrum. Self-contained scope (11 x 14 1/4 x 3") includes I.R. light source (for up to 90' sight at night!), 6032 I.R. converter tube, f/3.5 telephoto lens, adjustable triplet eyepiece, an adapter for use with your car's cigarette lighter—more! Bright 1.6X image (Binocular style gives super-bright 2.5X). Focuses from 10' to infinity, runs on 6 or 12v DC.



Not for sale to Cal. residents other than authorized by U.S. Armed Forces, law enforcement agencies or solely for scientific research and education purposes.

STANDARD STYLE, STOCK NO. 1683EH..... ONLY \$299.95 Ppd.
BINOCULAR STYLE, STOCK NO. 1685EH..... JUST \$329.95 Ppd.

COMPLETE AND MAIL COUPON NOW

EDMUND SCIENTIFIC CO. 300 Edscorp Bldg., Barrington, N. J. 08007

Send me the following:

Stock No. _____ Quantity _____ Price Ea. _____

SEND FREE 164 PG. CATALOG "EH"

Charge my American Exp BankAmericard Master Cng.

Interbank No. _____

Card No. _____

Expiration Date _____

30-DAY MONEY-BACK GUARANTEE. You must be satisfied or return any purchase in 30 days for full refund.

Signature _____

Address _____

City, State, Zip _____

Stock No.	Quantity	Price Ea.

Add handling charge \$ _____ 1.00
Enclosed is _____ check,
_____ M.O. in amount of \$ _____

RESEARCH DELIVERS A Quantum Jump in Record Care

New D3 Fluid

1. Unmatched activity plus safety to vinyl additives (the critical compounds of longevity).
2. A secret non-adhering anti-static system that is measured in parts-per-billion!
3. A special chemical "release system" (pat. pend.) that allows suspended contaminants to pull away from critical micro-grooves.

The Systems Approach Of the Discwasher Brush

D3 plus the patented directional micro-fibers and absorbent backing remove—rather than line up—all dust and suspended debris.

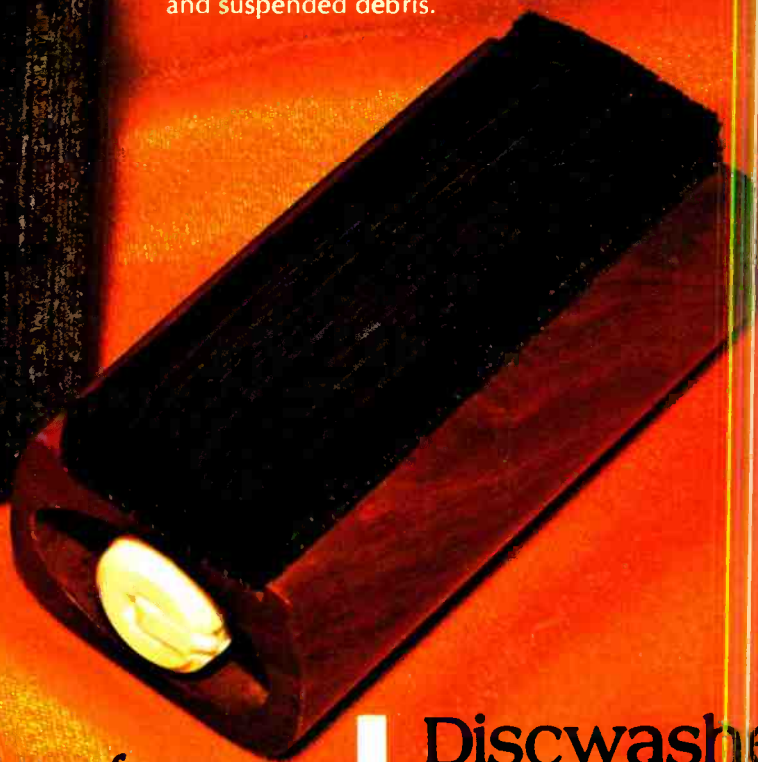

Research Delivers from



**Discwasher
Group**

1407 N. PROVIDENCE
COLUMBIA, MO 65201

CIRCLE 79 ON FREE INFORMATION CARD

www.americanaudiobooks.com



THE COBRA 32XLR. A TECHNOLOGICAL PUNCHTHROUGH.

Cobra has a reputation for punching through loud and clear. The new Cobra 32XLR, of course, continues the reputation. And creates another—for innovative design, superb engineering and technical superiority.

Start with the illuminated 4-in-1 meter. It tells you exactly how much power you're pushing out and pulling in. As well as monitoring your modulation in precise percentages. And measuring your punch with an SWR check. In short, the 32 XLR lets you keep an eye on your ears.

ScanAlert, Cobra's unique scanning system, continually monitors Channel 9 when you're on another channel. If an emergency comes up, the ScanAlert light goes on. And the incoming message automatically locks the receiver on the active channel.



The 32XLR's Digital Channel Selector is the very latest. With large LED numerals—for a read-out that registers clearly and quickly. Plus switchable "pulse block" noise blanking that rejects short-pulse noise not normally blocked by other systems. Which makes it the most effective in the business. Finally, add automatic noise limiting, Dynamike Plus (with built-in power mike) and Delta Tuning.

The new Cobra 32XLR. It has virtually everything. And it has everything to do just one thing. Punch through loud and clear.



Punches through loud and clear.

Cobra Communications Products
DYNASCAN CORPORATION
6460 W. Cortland St., Chicago, Illinois 60635